



**NANYANG
TECHNOLOGICAL
UNIVERSITY**

**DATA-DRIVEN PROCESS REDESIGN TO ENABLE
MASS CUSTOMIZATION OF HEALTHCARE SERVICES**

ZHANG XIAOJIN

School of Mechanical and Aerospace Engineering

A thesis submitted to the Nanyang Technological University
in partial fulfillment of the requirement for the degree of
Doctor of Philosophy

2014

ACKNOWLEDGEMENTS

Foremost, I would like to take this opportunity to express my sincerest gratitude and appreciation to my supervisor Asst. Prof. Chen Songlin for the continuous support of my Ph.D. study and research, for his patience, enthusiasm and abundant knowledge. His guidance, supervision and motivation helped me in all the time of research and writing of this thesis. It has been an honor to be his Ph.D. student.

Besides my supervisor, I wish to express my sincere gratitude to Ms. Ayliana Phe, Head of Management Information Department, Tan Tock Seng Hospital, for coordinating communication and providing valuable data. My sincere thanks also go to Asst. Prof. Moon Seung Ki, Asst. Prof. Carman K.M. Lee, and Assoc. Prof. Chen Chun-Hsien for their insightful comments and suggestions on this research.

I thank my fellow labmates in CHFEE: Xingyu, Yang Mei, Sun Ke, Shuli, Benedict, Fui Ling, Jiahong, Xinyao, Yang Xi, and Zhou Feng, for the discussions and for all the fun we have had in the last four years. Also I thank my friends in Singapore: Sangsang, Saw Ting, Roohi, Ningrong, Ayu and Danping, to name but a few. In particular, I am grateful to Zhang Youbang for his contribution.

I would like to thank my families: my parents Zhang Lihua and Li Hang, my husband Dr. Xiong Zhitao and my son Xiong Ruihai, for their unceasing support, encouragement and patient throughout my life. Without all your love and help, this thesis might not have been accomplished.

Lastly, I would like to thank the school and the laboratory to provide me a convenient environment to study and learn from others.

TABLE OF CONTENTS

ACKNOWLEDGEMENTS	I
TABLE OF CONTENTS.....	II
LIST OF FIGURES.....	IV
LIST OF TABLES.....	V
SUMMARY	VI
CHAPTER 1 INTRODUCTION	1
1.1 INTRODUCTION.....	1
1.2 RESEARCH OBJECTIVE AND SCOPE	5
1.3 RESEARCH APPROACH	7
1.4 REPORT ORGANIZATION	10
CHAPTER 2 LITERATURE REVIEW	12
2.1 MASS CUSTOMIZATION	12
2.1.1 <i>Mass Customization Concept</i>	12
2.1.2 <i>Value Creation in Mass Customization</i>	13
2.1.3 <i>Mass Customization in Service Industries</i>	15
2.2 HEALTHCARE DELIVERY	17
2.2.1 <i>The Nature of Healthcare</i>	17
2.2.2 <i>Healthcare Delivery System and Evolution</i>	19
2.3 TOWARDS MASS CUSTOMIZATION OF HEALTHCARE SERVICES	22
2.3.1 <i>Evidence-based and Personalized Medicine</i>	24
2.3.2 <i>Consumer-driven Healthcare</i>	27
2.3.3 <i>Consumer Health Informatics</i>	30
2.3.4 <i>Healthcare System Decentralization and Integration</i>	32
2.4 SUMMARY	37
CHAPTER 3 PATIENT-CENTERED PATHWAY IDENTIFICATION USING PROCESS MINING.....	38
3.1 MOTIVATION FOR PATIENT-CENTERED PATHWAY IDENTIFICATION	38
3.2 PROCESS MINING.....	39
3.2.1 <i>Process Mining Discovery Algorithms</i>	40
3.2.2 <i>Process Mining Applications</i>	41
3.3 PATIENT-CENTERED PATHWAY IDENTIFICATION	42
3.3.1 <i>Dependency Matrix Construction</i>	44
3.3.2 <i>Dependency Graph Construction</i>	46
3.3.3 <i>AND/XOR-split/join Constructs Identification</i>	48
3.3.4 <i>Process Model Evaluation</i>	49
3.4 A CASE STUDY OF PATIENT-CENTERED PATHWAY IDENTIFICATION.....	53
3.4.1 <i>Case Background</i>	53

3.4.2 Event Log Extraction and Preparation.....	54
3.4.3 Process Network Discovery through ProM.....	55
3.4.4 Process Network Conformance.....	57
3.5 SUMMARY	58
CHAPTER 4 MODULAR HEALTHCARE PROCESS REDESIGN USING DESIGN	
STRUCTURE MATRIX	60
4.1 MOTIVATION FOR PROCESS MODULARIZATION	60
4.2 DESIGN STRUCTURE MATRIX	61
4.3 MODULAR HEALTHCARE PROCESS REDESIGN	65
4.3.1 Healthcare Process Modularization and Sequencing Formulation.....	66
4.3.2 A New Modularization and Sequencing Algorithm	71
4.4 A CASE STUDY OF MODULAR HEALTHCARE PROCESS REDESIGN	76
4.4.1 DSM Representation of the Clinical Pathway.....	76
4.4.2 Results of Modularization.....	77
4.4.3 Results of Sequencing and Redesign	81
4.5 SUMMARY	84
CHAPTER 5 HEALTHCARE SERVICE CONFIGURATION BASED ON PROJECT	
SCHEDULING.....	86
5.1 SIGNIFICANCE OF HEALTHCARE SERVICE CONFIGURATION	86
5.2 RESOURCE-CONSTRAINED PROJECT SCHEDULING	88
5.3 HEALTHCARE SERVICE CONFIGURATION	93
5.3.1 Healthcare Service Scheduling Formulation	93
5.3.2 A Bi-level Scheduling Algorithm.....	95
5.4 HEALTHCARE SERVICE CONFIGURATION	100
5.5 SUMMARY	111
CHAPTER 6 CONCLUSION AND FUTURE WORK.....	113
6.1 RESEARCH SUMMARY	113
6.2 LIMITATIONS AND FUTURE WORK.....	117
REFERENCES.....	120
APPENDIX.....	132
APPENDIX A – AN EXAMPLE OF EMRS AND STRUCTURAL INFORMATION FROM TTSH.....	132
APPENDIX B – HEURISTIC NETS OF PROCESS MODELS.....	134
APPENDIX C – PETRI NETS OF PROCESS MODELS	138
APPENDIX D – THE CODE OF GA-BASED CLUSTERING AND SEQUENCING ALGORITHM.....	141
APPENDIX E – ³ FULL FACTORIAL EXPERIMENTAL DESIGN.....	148
APPENDIX F – RESULTS OF MODULARIZATION	151
APPENDIX G – THE CODE OF BI-LEVEL GA-BASED SCHEDULING ALGORITHM.....	153
APPENDIX H – ² FACTORIAL EXPERIMENT	164

LIST OF FIGURES

Figure 1.1: Comparison on patient with different number of conditions	3
Figure 1.2: The proposed research framework	7
Figure 2.1: The structure of a general healthcare delivery system.....	20
Figure 2.2: Evolution of healthcare delivery system and manufacturing system.....	21
Figure 2.3: Medicine paradigm transit	25
Figure 2.4: General transition towards mass customization of healthcare services	36
Figure 3.1: An overview of process mining (Van der Aalst 2011)	39
Figure 3.2: The procedure of pathway identification	43
Figure 3.3: The Heuristics Miner algorithm flow chart.....	52
Figure 3.4: A heuristic net representation of process model with all-activity-connected	56
Figure 4.1: A GA-based modularization algorithm	73
Figure 4.2: Individual encoding for modularity	74
Figure 4.3: Effect of number of modules on TCC	78
Figure 4.4: Effect of population size on TCC	79
Figure 4.5: The total feedback history for re-sequencing of care modules.....	82
Figure 4.6: The redesigned modular clinical pathway.....	83
Figure 5.1: A decision framework for mass customization of healthcare services.....	87
Figure 5.2: Healthcare package specification procedure	90
Figure 5.3: Classification of RCPS	90
Figure 5.4: An overall framework of a bi-level GA scheduling algorithm	96
Figure 5.5: A bi-level GA scheduling algorithm	98
Figure 5.6: CDF of M_1 processing time (LogN(2.7762, 0.7980))	100
Figure 5.7: The schedule and resources utilization status.....	107
Figure 5.8: The scheduled healthcare service package.....	109
Figure 5.9: The current makespan vs. makespan of the proposed method	110
Figure 5.10: Resource utilization rate vs. healthcare package resource reservation time.....	111

LIST OF TABLES

Table 2.1: Production paradigms and their key characteristics	13
Table 3.1: Process discovery techniques category	41
Table 3.2: An event log episode	54
Table 3.3: Fitness measurements for various process networks.....	58
Table 4.1: The <i>DSM</i> of all-connected-activity process network	76
Table 4.2: The selected result of modularization	80
Table 4.3: The <i>DSM</i> representation of modules.....	81
Table 4.4: The compressed <i>DSM_{cl}</i> representation by modules	82
Table 4.5: Information of minimum <i>TFB</i>	83
Table 5.1: Predecessor set, process structure and estimated processing time of redesigned clinical pathway	102
Table 5.2: Resource availability and capability in Clinic 3B.....	104
Table 5.3: Patient current appointment and makespan	105
Table 5.4: Selected options	106

SUMMARY

The state-of-art studies on mass customization in healthcare systems largely focus on medical sciences, informatics, management and technology domains, while little research has been devoted specifically to mass customization of healthcare services. Inspired by the success of mass customization in manufacturing industry and genetic value proposition of mass customization in terms of being demand driven, modularity, value co-creation and configuration, this research aims to investigate the theoretical feasibility and practical applicability of adopting mass customization for healthcare service delivery.

As healthcare is essentially a type of service that deals mainly with *processes*, this research focuses on the development of a data-driven approach for process redesign to enable mass customization of healthcare services. Corresponding to basic principles of mass customization, this research addresses three main issues of enabling mass customization in healthcare, namely *patient-centered pathway identification*, *healthcare process modularization*, and *healthcare service configuration*, respectively.

In patient-centered pathway identification, the basic rationale is to view healthcare services from the perspective of individual patients. This research develops a method based on process mining to extract the underlying structure of clinical pathways that reflect the mapping from individual patients' medical needs to diversity of healthcare services. The Heuristics Miner algorithm is adopted and implemented to discover clinical pathways in a case study. By varying the dependency threshold levels, a series of pathways are generated. The all-activity-connected pathway achieves the highest values in all fitness measurements, which can serve as a basis to devise customized pathways according to a patient's specific conditions.

Modularization is a key factor of mass customization to reduce process complexity and enhance flexibility in providing customized healthcare services. This research develops a process modularization and sequencing method based on design structure matrix (DSM), which groups closely interacted healthcare services into service modules through genetic algorithm (GA) to minimize total coordination cost. The performance of GA for modularization is analyzed by examining total coordination cost with respect to the key parameters. Sequences of service modules are adjusted in order to minimize feedback interactions among different modules. The clinical pathway is eventually redesigned into a modular clinical pathway based on the re-sequenced process modules and medical constraints.

With modular clinical pathway redesigned, it becomes possible for individual patients to configure their healthcare services. A decision support model is developed to integrate individual patients into the healthcare delivery process by providing their key preferences. Healthcare service configuration is essentially to generate an appointment schedule for a patient to receive a package of healthcare services. The configuration is formulated as a dynamic resource-constrained project scheduling problem in this research. A bi-level GA-based scheduling algorithm is developed for problem solving. The algorithm for healthcare service configuration is demonstrated by examining different schedules and the associated resource utilization. What-if analysis is conducted to compare the appointment scheduling time and makespan between the as-is and to-be cases. It is found that healthcare service configuration enables the healthcare services to be customized and delivered with high efficiency.

Mass customization of healthcare services is still a new concept. This research makes original contribution in terms of formulating the problem in a proper context and developing systematic methods towards its implementation.

CHAPTER 1 INTRODUCTION

This chapter first introduces challenges faced by the healthcare delivery system and recent developments as the general background of the proposed research. The research problem is then defined with specific objectives and scope articulated. The overall design of the research is outlined and key research issues are briefly discussed. Organization of the report is given at the end of the chapter.

1.1 Introduction

Healthcare systems around the globe are faced with enormous challenges to deliver high quality healthcare services at affordable costs to an increasingly long living and aging population (WHO 2000). Despite increasing healthcare spending, the rapid growth of demand for healthcare services has outpaced that of the supply of medical resources in both developing and developed countries (WHO 2006), resulting in restricted access to care, congested hospitals, long waiting queues, and compromised quality, among many other problems (Worthington 1991; IOM 2001). Given the already high percentage of healthcare expenditures in many national economies, the long-term sustainability of a healthcare system cannot rely solely on capacity expansion in terms of more hospitals, doctors, nurses, and more public funds but requires a redesign of the healthcare delivery system to make it more efficient and cost effective (Reid et al., 2005).

The healthcare delivery system has become a very complex service system. Increasingly specialized medical disciplines and care providers result in a large number of fragmented healthcare services offerings (Lenz and Kuhn 2004). The

delivery of healthcare services involves a wide range of distributed activities, performed by collaborative efforts of professionals with different skill sets, knowledge, and organizational culture, which often lead to high complexity, insufficient coordination, and lack of integration (Lenz and Reichert 2007, Mans 2008 and 2009).

A growing segment of the population exhibits more complex clinical manifestations and increasingly diversified healthcare needs who demands customized healthcare services. These patients are generally faced with different combinatory of multiple conditions (Drake and Lowenstein 1998; Vogeli et al. 2007). Patients with multiple conditions refer to people have two or more concurrent conditions including medical illnesses and physical problems (Anderson 2010). In the U.S., it is estimated that the number of patients with multiple conditions will increase from 63 million in year 2005 to 81 million in year 2020 (Anderson and Jane Horvath 2002). In current healthcare delivery system, patients are treated by standard disease-specific care pathways and advised to go through various departments, clinics and providers for care services (e.g. consultation, test, treatment) which are similar to jobs to be processed in a mass production factory. The supply-driven healthcare delivery system with increasingly specialized disciplines is becoming ineffective to fulfill the increasingly diversified patients' needs for healthcare services. Inefficiencies display in many aspects, i.e. long waiting time, high risks of conflicting medical advices, duplicate tests and unnecessary hospitalization (Bodenheimer 2008). In terms of medication, the complex clinical manifestations often results in recommendations of additional medications. Patients have the potential for harms associated with adverse drug-drug

interactions (Tinetti et al. 2004). Evidence can be found in Anderson (2001) and Vogeli et al. (2007) and is summarized in Figure 1.1.

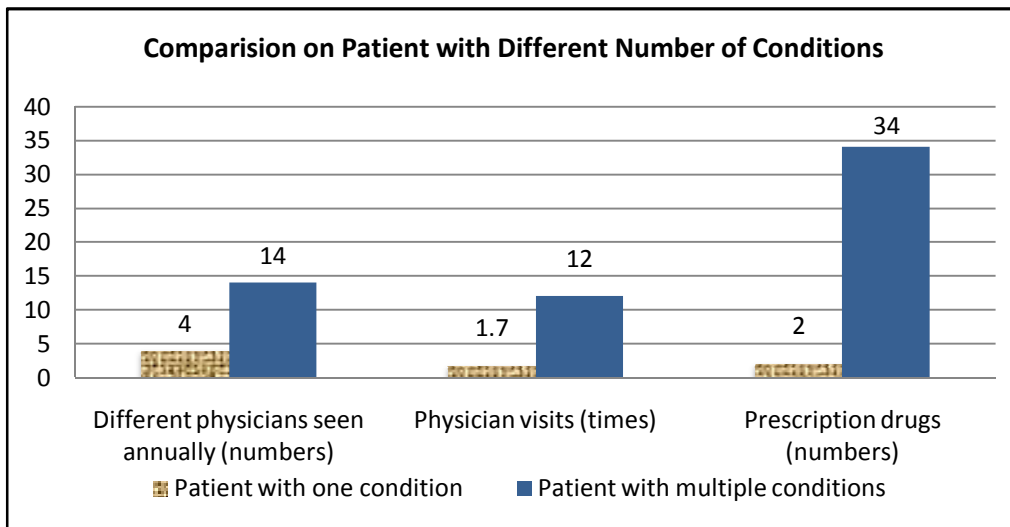

Figure 1.1: Comparison on patient with different number of conditions

Patients with multiple conditions see up to 14 different physicians annually and on average visit care providers 12 times while patients with a single condition only consult 4 physicians and visit care providers less than twice annually. It can be seen that these patients have to make many appointments with different specialties and visit care providers multiple times to get treatment. Furthermore, patients with multiple conditions are prescribed as many as 34 drugs which are 17 times more than patients with a single condition. Problems are going to be much more serious as there are a growing number of individuals with diversified and specific medical needs who need customized healthcare services to be tailored for them.

Given the enormous diversity in both patients' needs and healthcare service offerings, the healthcare delivery system is confronted with the challenge to offer an increasing variety of healthcare services according to individual patient's medical needs while in the meantime to control rapidly

increasing healthcare cost. A fundamental research problem to be addressed in this research is *how to fulfill a rapidly growing and increasingly diversified demand for healthcare services with a rapidly expanding portfolio of offerings but limited financial resources.*

This is not simply a clinical problem but requires solution on the system level. The Institute of Medicine (2001) of U.S. has called for a redesign of the healthcare delivery system so that “*care is customized according to patient needs and values*” and “*the patient is the source of control*”. Similarly, the World Health Organization (2000) advocates three goals, namely *good health, responsiveness to the expectation of the population, and fairness of financial contribution.*

If history could be of some reference, this challenge is not unique to the healthcare industry *per se*, but has been confronting manufacturing industries for decades. What is inspiring here is that the manufacturing industry has advanced to the age of *mass customization*, under which manufacturers are able to produce and deliver goods according to individual customers’ specific needs with high efficiency and low cost (Pine 1993; Tseng et al., 1996). *Is mass customization an appropriate paradigm for healthcare?* On the one hand, healthcare is similar to manufacturing in many ways and the healthcare industry has been historically learning from the manufacturing industry in both management innovation and technology adoption (Christensen et al., 2009). Some researchers have explicitly called for a redesign of the healthcare system based on mass customization (e.g. Chao 2003; Davila 2002), and other streams of research, e.g. consumer-driven health care (Herzlinger 2002; Herzlinger and Parsa-Parsi 2004) and personalized medicine (Langreth and Waldholz 1999;

Abrahams et al., 2005), are also pointing in this direction. On the other hand, healthcare remains fundamentally different from manufacturing in the sense that it is essentially a service where people's health or life is at stake (Tien and Goldschmidt 2009; WHO 2000). The different quality standards, regulatory framework, and industry structures make it a legitimate concern regarding how far the analogy between manufacturing and healthcare can be carried when it comes to adopting mass customization for healthcare.

However, up to date, little research has been devoted specifically to mass customization of healthcare services, although the topic has been touched upon in many fields of research including medical research, operations management, informatics and technology management etc.

1.2 Research Objective and Scope

This research aims to investigate the theoretical feasibility and practical applicability of adopting mass customization for healthcare service delivery. As healthcare is essentially a type of service that deals mainly with *processes* instead of *products* as in manufacturing, this research focuses on the development of *a data-driven approach for process redesign to enable mass customization of healthcare services according to individual patient's needs with high efficiency.*

However, there is a large spectrum of healthcare services, not all of which are suitable for mass customization. Two prerequisite conditions for mass customization are the existence of demand for customized products/services and the availability of flexible processes (Hart 1995). Based on these two dimensions, this research focuses on patients with multiple conditions as the main subject of study, as these patients tend to have non-regular and

individual-specific needs for healthcare services (Piette and Kerr 2006).

In the medical domain, this research focuses on the healthcare services that can be delivered with relatively high accuracy and precision, which corresponds to the “precision medicine” and “empirical medicine” as defined by Christensen et al. (2009). More specifically, the precision medicine refers to care for diseases that can be diagnosed precisely and for which treatments are predictably effective through algorithm-driven interventions. The empirical medicine refers to care for diseases that treatment outcomes can be described in probabilistic terms. This research leaves out “intuitive medicine”, which refers to care for conditions that are diagnosed by symptoms and treated with therapies of uncertain efficacy. If patients are with complicated problems and precise diagnosis is impossible, treatments must be given through intuitive testing and pattern recognition by experienced professionals. The intuitive medicine has been traditionally provided with customization, but it is not suitable for mass customization, which aims to provide customized services on a large scale with high efficiency.

It should be noted that the scope of healthcare services that are suitable for mass customization is dynamic instead of static. The scientific progress in diagnostic imaging, genetic identification and biochemistry has long been shifting diseases along the spectrum from intuitive toward precision medicine (Christensen et al. 2009). Many deadly diseases in the past can be cured with innovative drugs or therapies with routine procedures nowadays. In general, those patients whose diseases can be diagnosed precisely or at least well understood and verifiable, treatments can be delivered through the precision medicine or the empirical medicine, and healthcare services can be customized

according to individual patients' needs.

1.3 Research Approach

Mass customization has been proven an effective production paradigm in the manufacturing industry. Although healthcare differs from manufacturing in many significant ways, the basic value proposition of mass customization in terms of being demand driven, modularity, and value co-creation is generic and can be transferred for healthcare service delivery. Mass customization requires alignment of processes based on individual customers' needs, simplifying internal complexity while maintaining external variety to meet diversified needs, and integrating customers into value co-creation. Corresponding to these basic principles of mass customization, this research addresses three main issues of enabling mass customization in the context of healthcare: (1) *patient-centered pathway identification*, (2) *healthcare process modularization*, and (3) *healthcare service configuration*. The research framework is outlined in Figure 1.2.

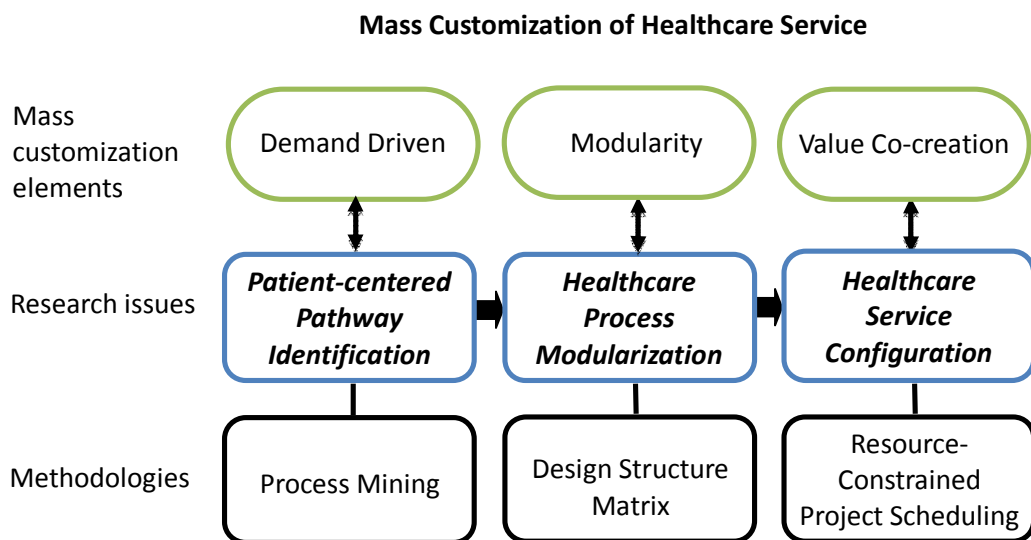

Figure 1.2: The proposed research framework

1) Patient-centered pathway identification

A key principle of mass customization is that it is a demand driven, customer-centric system. In the context of healthcare, this means healthcare services need to be delivered based on patients' individual-specific needs. To enable mass customization of healthcare services, a clear matching between an individual patient's needs and healthcare processes is necessary. The patient-centered pathway, from a patient's point of view, describes required healthcare services according to a patient's medical needs. However, the complexity involved in both diversified medical needs and numerous medical service offerings causes the difficulty to identify patient-centered pathway.

This research proposes a method based on process mining for patient-centered pathway identification. This method starts with an event log. The event log contains information extracted from electronic medical records (EMRs) of patients with the same or similar medical conditions. It details healthcare services execution information based on individual patients. The process discovery algorithm uses a statistical way to learn from the event log and distill a well-structured process network (i.e. clinical pathway). The discovered pathway essentially establishes the matching between a patient's medical needs with healthcare services by aggregating a group of patients' healthcare processes.

2) Healthcare process modularization

Modularity has been seen as a good way for low cost and efficient product design in mass customization. Healthcare process modularization is able to break up loosely linked healthcare services and arrange them into modules that can greatly reduce complexity and be performed rather independently.

Modularized healthcare processes facilitate care delivery to be better coordinated through flexible combination or configuration according to a patient's medical needs.

This research develops a process modularization method using DSM to represent dependencies between healthcare services from the complicated graph-based process model. Care modules are identified by grouping closely interdependent care services into clusters and at the same time minimizing interactions between different modules. The identified care modules are re-sequenced with the purpose of minimizing feedback information. The clinical pathway is redesigned based on the re-sequenced process modules and medical constraints. The outcome is a modular clinical pathway. It provides a foundation to support mass customization through flexible configuration.

3) *Healthcare service configuration*

With the redesigned modular clinical pathway, it becomes possible for individual patients to configure their healthcare services themselves or with the help of health professionals. Mass customization aims to integrate patients into the medical decision making in the healthcare package design and value co-creation.

Unlike product configuration in manufacturing, healthcare service configuration is to generate a schedule for a patient to receive different healthcare service modules. In other words, the configured healthcare package is essentially an appointment for a patient to receive a package of healthcare service modules. Healthcare service configuration is formulated as a multiple resource-constrained single project scheduling problem. The objective is to find optimum or near-optimum solutions that best fit the individual patient's

preferences, which takes into account the process constraint and resource availability in medical diagnosis. Eventually, the outcome is a healthcare service package which contains a serial of healthcare service modules for a patient.

In summary, by focusing on patient-centered pathway identification, healthcare process modularization, and healthcare service configuration, this research tackles some of the most important challenges in the transition from a physician-centered healthcare system that still operates on the doctrines of mass production towards mass customization of healthcare services, in which healthcare processes are organized around individual patients and value is collaboratively created by physicians and patients in terms of best meeting individual patients needs with high efficiency and low cost.

1.4 Report Organization

The remainder of this report is organized as follows: Chapter 2 is literature review which broadly surveys mass customization and healthcare service delivery research. The basic concept and recent development in each of these research streams are critically reviewed, and the gap in the existing literature on mass customization of healthcare services is summarized. The three main research issues in Fig. 1.2 will be addressed further in terms of significance to enable mass customization of healthcare services, proposed methodology for problem solving from Chapter 3 to Chapter 5. In Chapter 3, the motivation for patient-centered pathway identification is discussed. A method based on process mining is developed. A case study is used to illustrate the Heuristics Miner algorithm for clinical pathway identification. Chapter 4 presents the importance of modularity in healthcare. The clinical pathway redesign problem is

formulated using the DSM technique. A modularization and sequencing algorithm is developed using GA. A case is adopted to demonstrate the developed methods. In Chapter 5, a decision framework is proposed to enable individual patients to be integrated into the healthcare delivery process. In this framework, the healthcare service configuration is modeled as a resource-constrained project scheduling problem (RCPSp). A bi-level GA-based scheduling algorithm is developed to match a patient's medical needs and preferences with available resources. The feasibility of healthcare service configuration is demonstrated by a case study. Comparison and discussion on healthcare service delivery performance are given at the end of the chapter. Finally, Chapter 6 summarizes research work that has been done and discusses contribution and limitation of this research.

CHAPTER 2 LITERATURE REVIEW

This chapter reviews relevant literature in *mass customization and healthcare service delivery* research. The basic concept and recent development in each of these research streams are surveyed and critically reviewed, and the research gap is summarized at the end of the chapter.

2.1 Mass Customization

2.1.1 Mass Customization Concept

The concept of mass customization was first expressed in Toffler's book *Future Shock*, in which he predicted that future manufacturing enabled by information technology would be able to provide customized products on a large scale with little or no extra cost (Toffler 1970). The term 'mass customization' was first coined by Davis (1987) in his book *Future Perfect*, in which he described a trend where companies sought to micro-segment markets and offer unique products and services to customers. It was Pine and his colleagues who had popularized the concept of mass customization and ignited a wave of academic research and industrial experimentation (Pine et al., 1993; Pine 1993). In their work, mass customization was defined as the ability to provide individually designed products and services to every customer through high process agility, flexibility, and integration. Many authors propose more practical definitions by describing mass customization as a system that uses information technology, flexible processes, and organizational structures to deliver a wide range of products and services that meet specific needs of individual customers at a cost near that of mass-produced items (e.g. Hart 1995; Tseng et al., 1996).

Mass customization has attracted tremendous interests from both academia and industry in the past decades. The work involves many aspects in terms of theory development and implementation. Comprehensive and up-to-date literature reviews on mass customization are presented in Da Silveira et al. (2001) and Fogliatto et al. (2012).

2.1.2 Value Creation in Mass Customization

Although mass customization shares many common features with craft production, mass production, and lean production, it entails different ways of engaging customers and a different system for value creation. Table 2.1 summarizes key characteristics of different production paradigms.

Table 2.1: Production paradigms and their key characteristics

	Craft production	Mass production	Lean production	Mass customization
Goal	Customization, high quality	High efficiency, low cost	High quality, low cost	Customization, low cost
Economics	Differentiation and customer integration	Economies of scale	Waste reduction	Economies of scope, customer integration
Focus	Customer need identification and satisfaction	Efficiency through standardization and aggregation	Efficiency through continuous process improvement	Variety and customization through flexibility
Product	Custom products designed/engineered to order	Standard products built to inventory	Standard products built to order	Standard modules assembled to order
Market	Focused niche markets	Homogeneous mass market	Homogeneous market segments	Heterogeneous niche markets
Customer Involvement	High	Minimum	Low	Medium

It is important to note that the production paradigms described above are not mutually exclusive. Elements of craft production, mass production, and lean production can be found in mass customization. More specifically, identification of customer needs and definition of custom solutions in mass

customization are similar to those in craft production; standard modules used in mass customization can be mass produced in large batches; and order fulfillment in mass customization is essentially a pull-based system that is similar to lean production. Depending on the point of customer involvement, mass customization consists of a continuum of strategies between pure craft production and mass production with different levels of customization (Piller et al., 2004; Da Silveira et al., 2001). Mass customization heralds a new way of labor division between customers and manufacturers. Under mass customization, customers are no longer passively involved in the value creation process as in mass production but act proactively as a co-designer or co-producer by providing key design or production inputs. The key principles underlying mass customization are *economies of scope* and *customer integration* (Piller et al., 2004).

A precondition of mass customization is that there exists a fragmented market with diversified customer needs (Zipkin 2001). By offering a large variety of products and engaging customers into the product creation process, mass customization is able to best fulfill customers' individual-specific needs in terms of fit, function, and/or aesthetics. As a result, customers are generally willing to pay a premium for a customized product relative to a mass produced product that is designed for an "average customer". From a manufacturer's perspective, the success of mass customization hinges upon its capability to counter balance the additional costs associated with large product variety, increased operational complexity, and loss of economies of scale. In the last two decades, many methodologies and technologies have been developed to address these challenges in mass customization. For example, platform-based design

methodologies have been developed to design product families that can cater to diversified customers' needs while maintaining a relatively stable architecture that can be reused (Tseng et al., 1996); flexible and reconfigurable manufacturing systems have been developed to handle the dynamic production setups and changeovers; decoupling and postponement have been recognized as effective supply chain strategies that can achieve high responsiveness to customer orders with minimum inventory costs; and information technologies like user toolkits are able to facilitate the task of customer need elicitation and product definition.

In general, the value proposition of mass customization can be summarized as giving customers choices that best match their individual needs and enabling manufacturers to interact directly with customers thus efficiently utilize resources with minimum wastage. The key to the success of mass customization lies in the capability to seamlessly engage customers into the value creation process by involving them in the right tasks and giving them the right tools, and to effectively control cost by reducing operational complexity and/or increasing process flexibility. The continuing fragmentation of mass markets and advancement of enabling technologies make mass customization an increasingly more viable strategy (relative to mass production) in many industries.

2.1.3 Mass Customization in Service Industries

Although mass customization has been discussed in the context of manufacturing, its basic principles and concepts can be applied to service industries as well (Pine 1993, Da Silveira et al. 2001; Piller and Tseng 2010). It has been generally recognized that services are fundamentally different from

products in the sense that they are intangible, perishable, and their production and consumption are simultaneous (Fitzsimmons and Fitzsimmons 2008). As a result, services cannot be kept as inventory or delivered in an intermediate form. Despite these apparent differences, there are many similarities between manufacturing and service operations. Many management and technology innovations originally developed in manufacturing industries have found applications in service industries with significant improvement in efficiency. Citing examples like McDonalds, Levitt (1972) considered services as “manufacturing in the field” and advocated a production line approach to manage service operations. Sundbo (1994) postulated a thesis of convergence between service and manufacturing organizations based on modularization of service production.

Services have an inherent element of customization as customers are both the recipients and co-producers of the services (Fitzsimmons and Fitzsimmons 2008). A critical challenge faced with many service operations is how to efficiently handle customer introduced variability (Frei 2006). The general value proposition of services in terms of customer integration, customization and efficiency is consistent with that of mass customization in the context of manufacturing. Key concepts of mass customization, e.g. value co-creation, modularity and flexibility, can be generally transferred from manufacturing to the service context. Similar to modular product families, modular service portfolios have been proposed as a methodology for service design (Jiao et al. 2003, Sundbo 1994). Flexible service processes have been proposed as a solution to handle the high variability in customized service requests (Hart 1995). Mass customization is gradually finding applications in a wide range of

service industries that include finance, education, wireless communication etc. (Piller and Kumar 2006; Chen and Pau 2010). Deep discussions on service mass customization specific challenges can be found in Haas and Kunz (2010).

2.2 Healthcare Delivery

2.2.1 The Nature of Healthcare

There is ongoing debate regarding what healthcare really is and how it is different from manufacturing and other service industries. On the one hand, healthcare, like other products and services, is an economic resource that is subject to market dynamics in supply and demand (e.g. Herzlinger and Parsa-Parsi 2004; Porter and Teisberg 2006). Patients can be taken as consumers who demand healthcare to fulfill their medical needs. Healthcare providers supply healthcare in terms of medicines and/or treatments in exchange of a fee. The decision upon transaction is subject to patients' and healthcare providers' economic means and incentives. In this sense, the provision and consumption of healthcare are not that different from the production and consumption of manufactured products. On the operational level, there are also many similarities between healthcare delivery and goods production. Patients can be treated analogously as “jobs” to be processed, doctors as “technicians”, hospitals as “factories”, patient pathways as “routings”, and the analogy goes on (e.g. McCarthy 2006; Shih 2008). Based on such similarities, many operations management techniques originated in manufacturing are finding increasing applications in healthcare, including hospital capacity planning, emergency department staffing, and surgery room scheduling (e.g. Brandeau et al., 2004; Reid et al., 2005).

On the other hand, healthcare is fundamentally different from

manufacturing in the sense that it is essentially a type of *service*, which is generally characterized by such properties as simultaneity, perishability, and intangibility (Fitzsimmons and Fitzsimmons 2008). The diagnosis-and-prescription involved in healthcare is basically a problem solving process that is experimental in nature, which resembles that of other professional services such as legal counseling, financial advisory, and business consulting (Bohmer 2009). But, healthcare differs fundamentally from these services as well because it deals with people's health, which biologically defines the well-being of a human being. As succinctly pointed out by Miller (1978), "of all the objects in the world, the human body has a peculiar status: it is not only possessed by the person who has it, it also possesses and constitutes him." This basic biological difference between health and other assets makes it difficult to determine a market value for healthcare, and it exaggerates other forms of market failure such as moral hazard and asymmetric information (WHO 2000). As a result, healthcare carries significant social and moral values that go beyond its economic value, and human rights and dignity are important aspects of healthcare.

The above two camps of arguments reflect a fundamental gap of understanding regarding the nature of healthcare between engineering and medicine, with the former emphasizing the "economic and technical" aspects of healthcare while the latter emphasizing the "biological and social" aspects (Reid et al., 2005). Some researchers argue that such a dichotomy of views is over simplified and they suggest that there is a spectrum of healthcare between these extremes. For example, Christensen et al., (2009) define three categories of healthcare, namely *precision medicine*, *empirical medicine*, and *intuitive*

medicine. Precision medicine refers to care for diseases that can be diagnosed precisely and for which treatments are predictably effective through algorithm-driven interventions; empirical medicine refers to care for diseases that treatment outcomes can be described in probabilistic terms, and intuitive medicine refers to care for conditions that are diagnosed by symptoms and treated with therapies of uncertain efficacy. Precision medicine is close to manufacturing in nature while intuitive medicine is close to professional services, and empirical medicine is somewhere in between.

2.2.2 Healthcare Delivery System and Evolution

A health system is defined to include *all the activities whose primary purpose is to promote, restore or maintain health* (WHO 2000). Such activities include formal health services like the professional delivery of personal medical attention, all use of medication, home care, public health promotion and disease prevention, health insurance, regulation, as well as medical education etc. Similar to the Institute of Medicine (IOM) of U.S. (2001), this research defines a *healthcare delivery system* as a subset of a health system by focusing on *activities that are directly involved in the provision, transaction, and consumption of healthcare services*. Figure 2.1 illustrates the structure of a general healthcare delivery system.

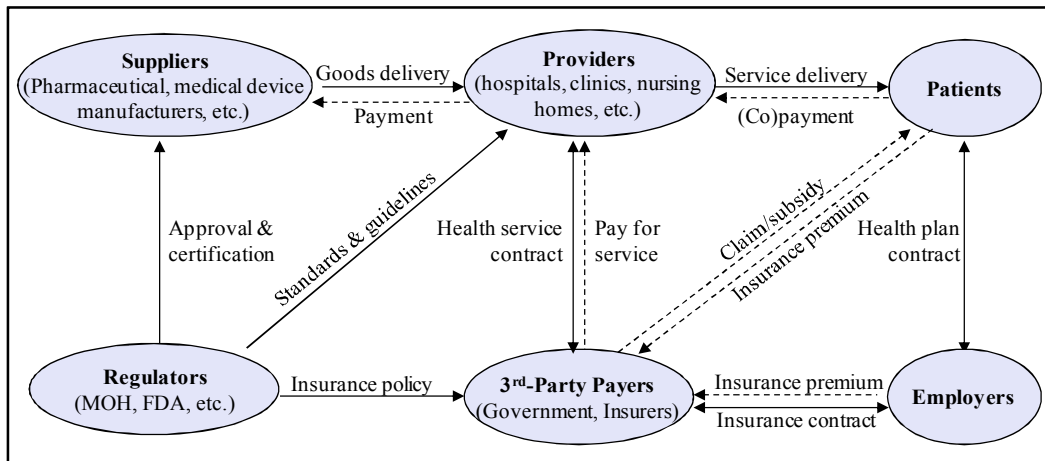

Figure 2.1: The structure of a general healthcare delivery system

The backbone of a healthcare delivery system lies in the *suppliers-providers-patients* axis. The suppliers (including pharmaceutical companies and medical device manufacturers etc.) supply medicine and medical equipment, based on which healthcare providers (including hospitals, clinics, nursing homes, and households etc.) provide healthcare services in terms of diagnoses, prescriptions, and/or surgeries to patients. The product and service flow is quite straightforward, but the reverse capital flow is more complicated. Patients' payment for healthcare services depends on their insurance plans. For those without any insurance, the whole price of healthcare services is borne by the patients. For those with insurance (universal coverage provided by government, health benefits offered by employers, or self-purchased health insurance from insurers), patients pay a proportion for the healthcare services as co-payment and 3rd party payers (including government and insurers) are responsible for the rest. There is usually a complex contracting and auditing relationship among patients, employers, 3rd party payers and healthcare providers regarding the insurance premiums and claims of healthcare expenses. Furthermore, healthcare delivery systems are usually highly regulated

by various government agencies regarding various healthcare issues including safety, quality, and equality etc.

The evolution of the healthcare delivery system relative to the manufacturing industry indicates that the healthcare system has been a follower of the manufacturing industry in terms of management innovations. Figure 2.2 sketches a historical timeline of the major paradigm shifts in the evolution of healthcare delivery systems relative to manufacturing systems.

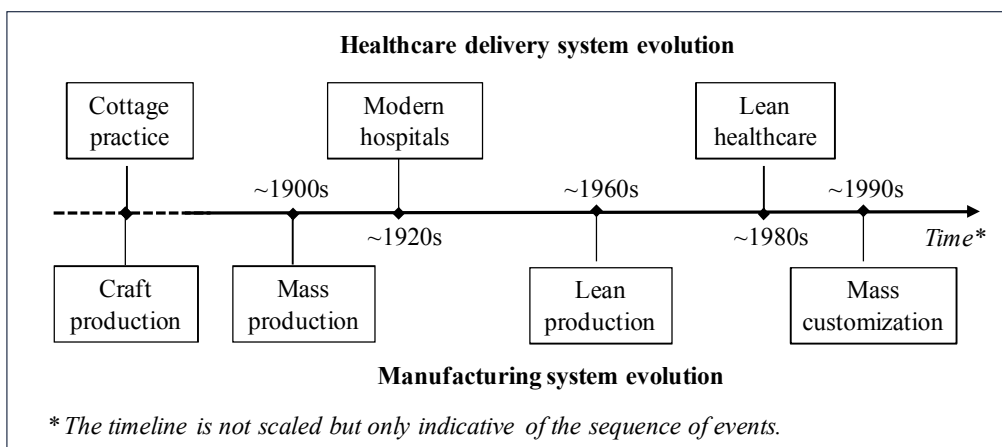

Figure 2.2: Evolution of healthcare delivery system and manufacturing system

Both healthcare and manufacturing started as cottage industries, in which healthcare services and manufacturing products were customized to the needs of individual patients and customers, respectively. The invention of machines during industrial revolution and the adoption of standard, interchangeable parts eventually led to the rise of *mass production* as a dominant paradigm for manufacturing, epitomized by Henry Ford’s assembly line in the early 20th century. In the meantime, modern medicine based on chemistry and biology gradually became the foundation for healthcare, and hospitals emerged as a central place to house medical equipment and provide medical treatment. It was an interesting anecdote that Henry Ford funded and built one of the biggest

general hospitals in Detroit in 1920s based on a blueprint adopted from mass production (Smits et al. 2003). Championed by Toyota, lean production emerged in the 1960s as a new manufacturing paradigm, in which production is demand driven pulled by actual customer orders instead of demand forecast. Activities that do not contribute to fulfilling customer demand were deemed as wastage in a lean paradigm and should be removed relentlessly. By aligning production with demand and streamlining production and distribution processes, lean production was able to deliver high customer value with low cost. Recently, lean production as a conceptual framework has been adopted to improve quality, reduce cost, and improve patient satisfaction in healthcare (Jimmerson et al. 2005). Other initiatives have been witnessed towards establishing a new paradigm for healthcare delivery system, such as managed care (Miller and Luft 1994), and total quality management (Shortell et al. 1995). Developments in the healthcare system show that most of paradigms were originated in the manufacturing industry.

A drawback of lean production lies in its inefficiency in handling highly diversified demand. Mass customization has emerged as a new manufacturing paradigm that promises to deliver products and services according to individual customers' needs with high efficiency that is comparable to mass production (Pine 1993, Tseng et al. 1996). The healthcare industry is currently faced similar challenges as patients are biologically different and have individual-specific needs for healthcare services.

2.3 Towards Mass Customization of Healthcare Services

Current healthcare delivery systems are still operated mainly based on a mass production paradigm and the concept of mass customization can be

applied to service industries in general. Healthcare, like other products and services, is an economic resource that is subject to market dynamics in supply and demand (e.g. Herzlinger 2004; Porter and Teisberg 2006). Generally, patients can be taken as consumers who demand healthcare to fulfill their medical needs. Healthcare providers supply healthcare in terms of medicines and/or treatments in exchange of a fee. The decision upon transaction is subject to patients' and healthcare providers' economic means and incentives. In this sense, the provision and consumption of healthcare services are not that different from the production and consumption of manufactured products like a computer or car. Operations in most hospitals, like factories, are composed of different functional departments staffed with different health professionals, and patients flow through the system undergoing different treatments in a similar way as a product going through an assembly line. Thus, on the operational level, there are many similarities between healthcare delivery and manufacturing production. Based on this reasoning, the basic value proposition of mass customization can be transferred for healthcare service delivery.

In addition, mass customization has a special appeal to healthcare delivery as every patient is biologically different and has individual specific needs for healthcare services. By mass customization of healthcare services, care providers are able to provide customized healthcare services based on individual patient's medical profiles and specific needs. Growing research in a wide range of fields is contributing towards mass customization of healthcare services. Technological advancement and innovations are leading the healthcare industry into a new era of mass customization (Pine and Gilmore 2001; Laiacona 2001). Science and technology advancement both in medicine and in

other disciplines like information and communication has fundamentally changed the ways that how physicians and patients can interact and how healthcare services can be delivered. There is an underlying shift in the relationship between physician and patient. New technologies and new medical science enable physicians to diagnose increasingly precisely and for which treatments are tailored with predictably effective for individual patients. Focused value adding processes on treatment contribute to improve efficiency while reducing cost in care providers. At the same time, new information and new communication technologies make patients to be more informed and educated. Patients know much better about their own health so that they are capable of participating in care delivery by self-caring and in charge of both cost and health. Together these changes are helping shape a new framework for healthcare delivery - one that is centered on mass customized care.

2.3.1 Evidence-based and Personalized Medicine

Much like physics and chemistry are the scientific foundation of modern manufacturing, healthcare service delivery is fundamentally governed by the science of medicine. Traditionally, medical prescription and treatment were conducted through physical symptoms observation, intuitive experimentation, and a process of trial-and-error. With the advancement of medical knowledge and technology, physicians are able to diagnose and deliver treatment with increasing accuracy and precision. Christensen's (2009) "intuitive → empirical → precision" framework provides a succinct description of the transition of healthcare service provision as our knowledge in medicine accumulates and advances. Figure 2.3 illustrates a general paradigm shift of medicine towards enabling mass customization of healthcare services.

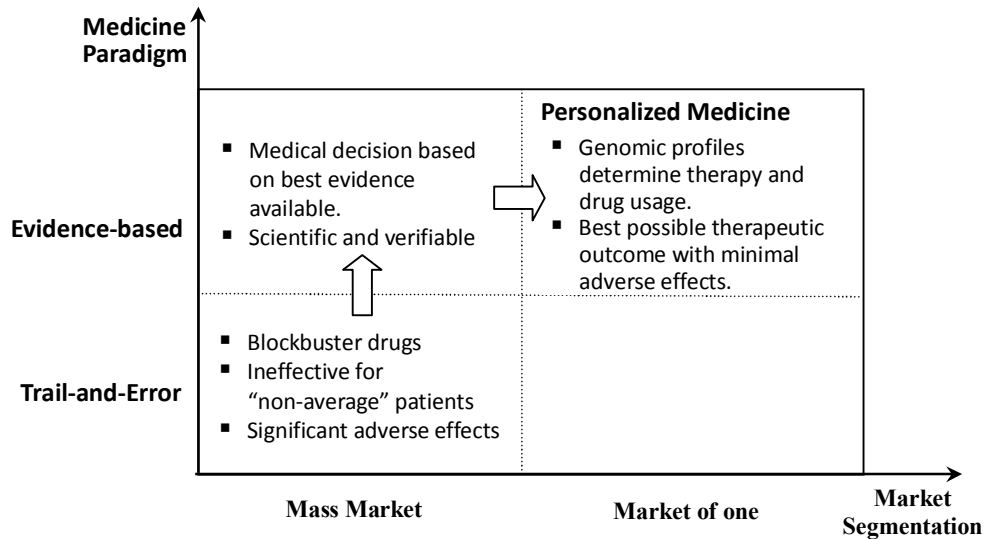

Figure 2.3: Medicine paradigm transit

The predominant methodology for medicine development is to seek a blockbuster, one-size-fits-all solution for a mass market. New medicine is usually developed targeting a representative condition or an “average” patient in a market segment. The developed drug is then tested with selected patients in clinical trials. Results are compiled statistically to determine the effectiveness of the drug, based on which drugs are produced in accordance to the “average” patient so that maximum market can be addressed. However, increasing evidence has shown that many patients, especially those with unique medical conditions, are often not responsive to the so-called blockbuster drugs; and even worse, significant adverse effects are often observed (Robert et al., 2004). On the front of healthcare service delivery, it has been often quoted that “medicine is more an art than a science”. It was also found that medical decisions are complex, highly uncertain, and prone to human errors (Wennberg and Gittelsohn 1973). For the same illness, there is a wide range of variation in terms of treatments and effectiveness across different physicians, hospitals, and regions. Such variations imply a “quality chasm” in healthcare service delivery

(IOM 2001).

Evidence-based medicine seeks to address variability and its associated quality issues in healthcare service delivery by anchoring medical decision making upon verifiable evidences. Evidence-based medicine is defined as “the conscientious, explicit and judicious use of current best evidence in making decisions about the care of individual patients” (Sackett et al., 1996). The basic premise of evidence-based medicine is that: there is one and only one best prescription and treatment for a given condition of a specific patient. Although every patient is unique in terms of medical conditions and needs, the delivery of healthcare should be under discretion of individual physicians who are able to synthesize all of the important information about the patient, the relevant research readily available, and experiences with previous patients to determine the best course of action (Eddy 2005). Recent development in healthcare information (e.g. clinical trials, medicine effects, and intervention reviews etc.) and communication have made it possible for health professionals to integrate clinical expertise and external evidence in making decisions about the care of individual patient. The rapid accumulation of medical evidences paves the way towards standardization in diagnosis and treatment. With sufficient amount of evidences, medical decision making could be implemented via some form of algorithm, which takes into account all the evidence available and suggests the best prescription or treatment accordingly. Thus, development in evidence-based medicine establishes a foundation that is able to capture medical knowledge on a population level, while in the meantime allowing customization of healthcare services tailored to individual patients based on individual-specific conditions.

Advancement in the field of genomics further pushes the boundary of medical knowledge and makes it possible to develop personalized medicine, which promises more potent and precise medical treatment according to individual patients' genetic information and other unique characteristics (Gurwitz and Manolopoulos 2007; Amir-Aslani and Mangematin 2010). Personalized medicine is prescribed based on an individual patient's genetic profiles, susceptible health conditions, and responses to a particular therapy. In other words, personalized medicine can eliminate unnecessary treatments, minimize the potential for adverse drug events, and, ultimately, improve patient outcomes. As personalized medicine is increasingly becoming a reality, healthcare services can be customized for each individual patient. Personalized medicine thus paves a foundation to design a healthcare delivery system based on the concept of mass customization.

2.3.2 Consumer-driven Healthcare

Most contemporary healthcare systems can be described as supply-driven and physician-centered, in which physicians choose the products/services purchased by patients or by third-party payers on behalf of the patients (WHO 2000; Powell and Laufer 2010). The physician centric structure generates a number of inefficiencies. First, there is an inherent conflict of interest. Healthcare providers are usually paid based on the services they provided, a practice that is often referred to as "fee for service". Under this compensation structure, physicians are motivated to over-treat a patient by means of additional tests or expensive procedures, even though the clinical benefit of the incremental care might not justify the associated risk (Harshbarger and Bohmer 1999). Such conflict of interest also occurs upstream in healthcare supply chain.

The financial arrangement between healthcare providers and suppliers of medicine or medical devices may steer clinical decisions towards high cost solutions (Christensen et al., 2000). Second, the high costs of litigation and malpractice insurance motivate physicians to practice defensive medicine, which often has minimal clinical value for the patient (Kessler and McClellan 1996). Empirical studies have shown that there is over-prescription of non-necessary diagnostic procedures across a wide range of medical disciplines. Third, as patients bear little of the direct cost of healthcare in traditional health coverage, they tend to over-consume medical resources by demanding expensive medicines or treatments. Given the loopholes listed above, there are enormous efforts by insurers to audit and control medical claims and by governments to regulate the healthcare industry, which translate into high overhead cost.

Consumer-driven healthcare is emerging as a new model of health coverage that promises to address many of the inefficiencies inherent in a supply-driven healthcare system. Herzlinger (2002) describes consumer-driven healthcare as “a new model of health coverage”, which “places control over both costs and care directly into the hands of employees (patients)”. Powell and Laufer (2010) define consumer-directed healthcare as “a systems approach that motivates individuals to shop for providers based on publicly available information regarding price and quality”. Despite the differences in definitions, consumer-driven (or consumer-directed, these two terms are used interchangeably in this thesis) healthcare generally refers to a market-based approach for health insurance transaction, in which patients purchase health plans based on their needs and the price of different healthcare services. By

putting patients in charge of healthcare dollars through personal Health Savings Accounts (HSAs) or other similar payment products, consumer-driven healthcare motivates patients to be discretionary in healthcare spending and forces healthcare providers to compete for patients' patronage. Thus, a shift towards consumer-driven healthcare can potentially realign the incentives of various parties in a healthcare system towards delivering superior value to patients, and the competitive pressure among providers could spur productivity and innovation that will improve quality and drive down cost (Herzlinger and Parsa-Parsi 2004).

There is ongoing debate regarding the novelty and viability of consumer-driven healthcare. Proponents believe it to be a revolution that will change the entire system while critics consider it as no more than a tweak of the current system (Scandlen 2005). Supporters believe consumer-driven healthcare will encourage patients to become better-informed, more cost-conscious users of healthcare while opponents worry that patients will obtain fewer necessary and nonessential services alike (Wilensky 2006). In recent years, a number of studies have been reported in literature regarding the implementation issues and performance implications of consumer-driven healthcare. Herzlinger and Parsa-Parsi (2004) cite Switzerland as an example that has a functioning national customer-driven healthcare system, which achieves universal insurance and high quality of care at significantly lower costs than the employer-based US system. Buntin et al., (2006) confirm that consumer-driven plans are associated with both lower costs and lower cost increasing, but their effects on quality are non-conclusive with evidence of both appropriate and inappropriate changes in care use. Their studies indicate that consumer-driven healthcare plans do reduce

healthcare consumption, especially when patients share a large proportion of the cost.

In general, consumer-driven healthcare attempts to bring commercialism into healthcare and employs the invisible but powerful hand of market competition as the driving force to improve efficiency, quality, and reduce costs. Although commercialism is controversial and equality of care might be compromised, it is the most promising if not the only route towards realigning the incentives and unleashing innovation in an increasingly complex and dysfunctional healthcare system. As pointed out by WHO (2000), “If services are to be provided for all, then not all services can be provided”. The real debate is not whether we should embrace commercialism or not but how we can engage patients and best utilize the power of market. Despite various challenges in its early implementations, consumer-driven healthcare will rise and transform the healthcare systems towards the needs and value of individual patients.

2.3.3 Consumer Health Informatics

In parallel to the development in fundamental medical science and medicine technology, there has been tremendous progress in the communication and information technology on the front end with patients. Traditionally, physicians had tight control over all medical information. But there is an increasing trend on reaching patients directly through computer networks in the recent decades to support and facilitate education, decision-making, communication, and many other activities. So that consumer health informatics emerged in response and is defined as “the branch of medical informatics that analyses consumers' needs for information; studies and implements methods of making information accessible to consumers; and models and integrates

consumers' preferences into medical information systems” (Eysenbach and Diepgen 2000).

Through the Internet such as web service, open data source and digital television, widely available and accessible medical information greatly influences and changes the way patients learn, think and communicate. Firstly, patients are well equipped with fundamental medical knowledge including sickness prevention, disease symptoms, self-management, self-treatment and functional recovery etc. Although, these information do not and cannot replace physician visit; they can make it possible for individual patients to be actively engaged in healthcare decision making and encountered more productive for both doctor and patient (e.g. Bodenheimer et al., 2002; McDaniel et al., 2008). Secondly, Electronic Health Records (EHR) has found increasing applications in healthcare and promises great potential for efficiency improvement and cost saving (Makoul et al., 2001; Hillestad et al., 2005). This is because, on the one side, different care providers can access to the level of details regarding patient’s drug allergy, kidney or liver function, lab results and other institutions’ diagnosis; on the other side, patients are informed with their own health and taking more response to therapy. Last but not least, the development of consumer informatics based expert systems can support complex medical decisions making by synchronizing patient’s self-updated treatment outcome, personal risk factors, scientific evidence and even patient’s satisfaction. As a result, care services can be tailored to individual patients on a value co-creation base.

Information technology as a powerful force is leading healthcare moving towards mass customization. The availability of consumer informatics provides

cheap and effective means to link personal information to healthcare resources. Healthcare providers can communicate with individual patients and involve them into the healthcare delivery process, not simply as passive services recipients, but as active value co-producers. And, this helps to break down the barrier of information asymmetry and information stickiness that is often encountered in mass customization. Patients are becoming better informed and are more actively involved in the healthcare delivery process with the development of health informatics (Bodenheimer et al., 2002).

2.3.4 Healthcare System Decentralization and Integration

The delivery of the healthcare is essentially a type of service that deals mainly with processes instead of products as in manufacturing. On the operational level, the healthcare delivery process is as a collection of care services, which consume resources and constitute points in time. We are seeing a shift towards an increasingly complex and decentralized healthcare system (Scott et. al, 2000). Provision of healthcare is gradually moving from over-congested general hospitals into community hospitals, nursing homes, or even households. The problem now is that there is a knowledge gap of what are going on in various providers. There are emerging trends towards individual patient involvement in the healthcare delivery and system-level integration.

The development in the information technologies (e.g. smart phones, electronic health records, social network and home health monitoring technologies) is having big impacts on self-care, health coaching and patient groups, as data can be shared among patients, researchers, and provider communities. Self-care is exercising by individual patients to maintain health. People search and learn from the Internet to prevent themselves and their

families to be ill through eating balance, practicing good hygiene and avoiding health hazards. At the same time, people also take care of minor ailments, long term conditions, or their own health after discharge hospitals. For those patients with similar conditions, they form different groups to discuss symptom, treatment, and medical effectiveness in order to monitor their health over time and learn from real-world outcomes. For example, a social networking health site called PatientLikeMe enables members to find and communicate with patients like them, gain social support, and learn first-hand about ways to cope and manage (Brownstein et al., 2009).

The traditional healthcare delivery system centralized around hospitals is giving way to a more decentralized system that involves community hospitals, nursing home, and individual households. The lack of system integration problem has been discussed (Casalino et al., 2003; Stille et al., 2006; Bodenheimer 2008). For example, an increasing number of patients with chronic diseases require various care services across different providers. Patients have to act as a self-coordinator most of the time (Bodenheimer 2008). Poorly-coordinated care between acute and long-term providers can result in ad hoc transitions and non-optimum care delivery. Many patients have experiences on conflict medical advice, duplicate tests and unnecessary visits. Porter and Teisberg (2004) address the issue by suggesting that information transparency and pricing mechanisms across different providers in the healthcare system should be established.

Christensen et al. (2009) proposed “focused value-adding process” hospitals and clinics as a strategy to strike a balance between efficiency and organizational flexibility. Focused value-adding processes are built in the sense

of optimizing the procedure to achieve consistent delivery of standard care. By focusing on a specific and well defined condition or procedure, focused value-adding processes are able to significantly reduce cost and improve quality. From a system-level point of view, complementary or partially over-lapping value-adding process hospitals and general hospitals are able to respond flexibly to a dynamic mixture of custom and standardized healthcare processes. The “focused value-adding processes” are similar in concept to the “focused factory” in the manufacturing context.

There has also been a growing stream of research concerning strategic system integration and coordination in literature. Bohmer (2005) puts forward a patient-oriented approach to fit heterogeneous and homogeneous medical demands through custom and standard care processes respectively. Sets of standardized clinical sub-processes are selected from a pre-defined protocol and combined seamless to treat patient from one to another. This approach enables the healthcare system to master both custom care and consistent standard care to obtain advantages in quality, cost and diversification. Dowd (2005) proposed “coordinated agency” and “autonomous consumers” two models. In the former model, care providers act as patient’s agent and address challenges in market on patient’s behalf. In the latter, consumer-directed health plan model envisions autonomous, well-informed, price-conscious consumers shopping among providers unconstrained by organizational affiliations. Meyer et al. (2007) propose a platform-based approach for healthcare services design. The platform is a set of sub-processes which are common to all patients, while modular sets of processes for individual services. The authors apply modular approach to designing service packages and show improvements in care delivery. Recent

papers concern more about effects of patient's behaviors. Qu and Shi (2011) present a model to capture appointment scheduling in open access clinics when considering patient choice of appointments. And authors investigate impacts of patient choice on the performance of provider capacity policies. De Blok et al. (2013) explain how interpersonal behavior responsive to individual patient's needs and values can be accommodated in modular care provision in the healthcare system context.

In sum, healthcare system integration tends to engage patients in care delivery process so that they are able to participate in medical decision-making and take responsibilities of their own health. Integration also facilitates coordination among care providers so that comprehensive healthcare services based on individual patient's needs can be offered in an efficient manner. System integration as a means brings about patient involvement and a cost-effective way to achieve mass customization of healthcare services. Literature on general transition trends in a healthcare delivery system towards mass customization of healthcare services is summarized in Figure 2.4.

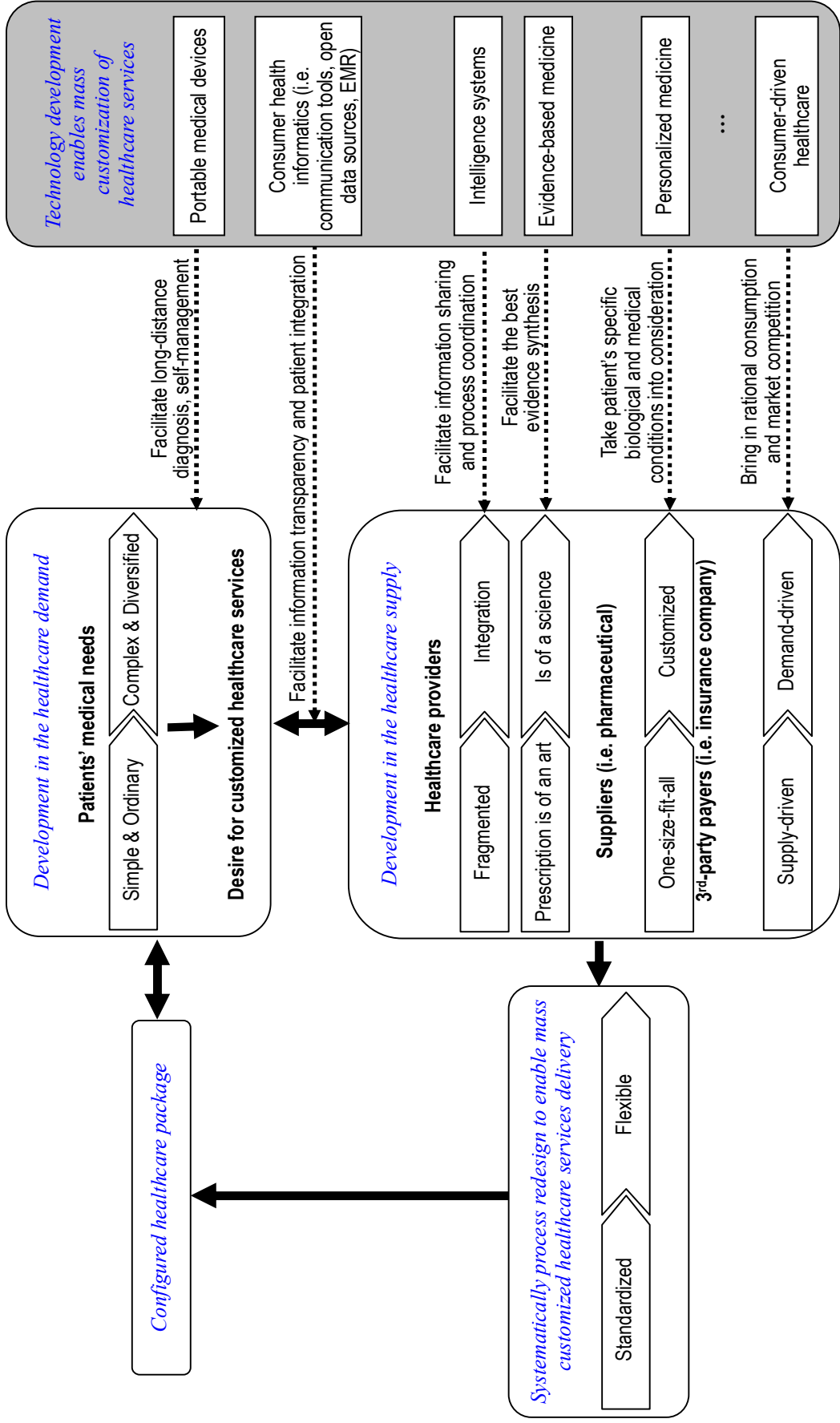

Figure 2.4: General transition towards mass customization of healthcare services

2.4 Summary

Mass customization has been proven an effective strategy to fulfill customers' individual specific needs with high efficiency and low cost in the manufacturing industry. Although healthcare differs from manufacturing in many significant ways, the basic value proposition of mass customization in terms of being demand driven, standardization, and value co-creation is generic and can be transferred for healthcare service delivery. The advancement and convergence of multidisciplinary studies reviewed above point to potential application of mass customization as a new paradigm for healthcare service delivery.

Mass customization of healthcare services however is still a new concept both in academic research and industry application. Despite growing interest in research topics that are related to mass customization of healthcare services, researches have been currently devoted in various fields of different disciplines including medicine, information technology, operations research and management etc. There is a lack of a unified conceptual framework to study mass customization of healthcare services in academic research. There is also a lack of systematic methodology to assist practitioners in the transition of a healthcare service delivery system that works on the doctrines of mass production towards a system that operates on the principles of mass customization.

CHAPTER 3 PATIENT-CENTERED PATHWAY IDENTIFICATION USING PROCESS MINING

The patient-centered pathway identification is a prerequisite to enable the transition towards mass customization of healthcare services. This chapter proposes to apply process mining for patient-centered pathway identification. Literature review on process mining is given in Section 3.2 which mainly covers discovery algorithms and its applications. A method of applying Heuristics Miner algorithm on pathway identification for patients with multiple conditions is presented in Section 3.3. A case study is adopted to illustrate the algorithm in the study.

3.1 Motivation for Patient-centered Pathway Identification

A key principle of mass customization is that it is a demand driven, customer-centric system. In the context of healthcare, this means healthcare processes to be delivered based on patients' individual-specific needs. A prerequisite of enabling mass customization of healthcare services is to understand how healthcare services are delivered from individual patients' perspective. In other words, it is essential to establish the mapping relationship between clinical pathways and individual patients' medical needs. A clinical pathway refers to a patient's journey through the healthcare system. It outlines steps of professional healthcare services (e.g. consultation, test, treatment) that are likely to happen on the patient's journey. Unlike customers demanding physical products in the manufacturing industry to fulfill their needs, what a patient actually demands is a package of healthcare services determined by his/her medical profile. For patients with multiple conditions in this study, the problem is to know how a particular patient with certain conditions flows through the healthcare delivery system. The overall journey of an individual patient is what we called a

patient-centered pathway.

Given difficulties such as complex patient flow, desultory data, and incorrect documentation, studies on developing systematic methodologies for pathway identification are needed. Pathways with correct ordering and network constructs are essential to provide the mapping from patients' medical profiles to healthcare services. Therefore, we propose a method based on process mining to identify patient-centered pathway.

3.2 Process Mining

Process mining technique is pioneered by Agrawal et al. (1998), and Cook and Wolf (1998). The basic idea of process mining is to learn from an event log which contains data extracted from information systems. Patterns are identified from the event log using statistical methods and process networks are discovered to present the process flow and constructs. Figure 3.1 shows an overview of process mining relationship.

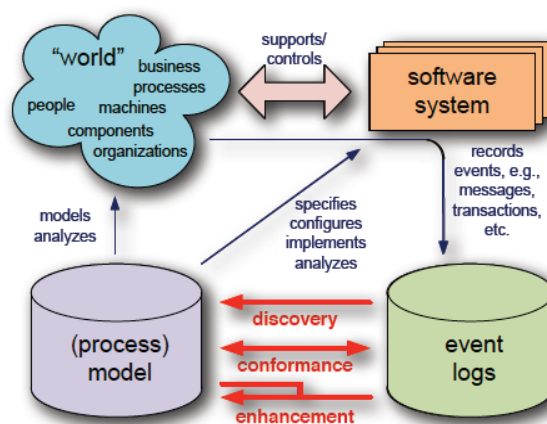

Figure 3.1: An overview of process mining (Van der Aalst 2011)

Information systems in an organization records activities that have been executed. The stored information is also known as event logs which provide detailed information (e.g. timestamp of the activity and the originator or performer of the

activity), which allows the discovery of process networks.

Process mining has demonstrated its capability to learn from a given event log and distill a well-structured process model in a wide range of service industries including software, insurance, healthcare etc (Cook and Wolf 1998; Rozinat et al. 2008; Mans et al. 2008). Furthermore, process mining is able to handle vast amounts of inaccurate data in event logs and it can discover a process network that strikes the right balance between generality and specificity (Rozinat et al. 2007).

Along the development in EMRs, laboratory information system (LIS) and financial information system (FIS), the healthcare services that patients have gone through are able to be obtained. Detailed healthcare services delivery information (e.g. consultation, test, treatment) are recorded in the form of *event logs*. In the context of health, healthcare services can be treated analogously as activities with timestamp and originator (e.g. nurse, doctor).

Process mining method can help us to capture the patients' medical needs and map to the clinical pathway shown in the form of process network. Of course, if the relevance medical knowledge is available and the provision of care for diseases can be precisely diagnosed, patients can be treated with rule-based therapies and predictably effective services. Process mining is no longer needed to figure out the mapping.

3.2.1 Process Mining Discovery Algorithms

Studies of process mining method generally fall in following three aspects, namely discovery, conformance, and enhancement. Process discovery techniques is one of the aspects have been intensively studied. Process discovery techniques refer to those algorithms that can automatically construct process models based on knowledge learnt from an event log. Tiwari et al. (2008) and Van Dongen et al. (2009) provide a comprehensive review on various process mining algorithms. In general, the widely

used algorithms can be categorized into three types. The representative algorithms and mining procedures for each type of algorithm are summarized in Table 3.1.

Table 3.1: Process discovery techniques category

Type of algorithm	Representative algorithms
Abstraction-based	α -algorithm (Van der Aalst et al. 2004) $\alpha+$ -algorithm (De Medeiros et al. 2004) Tsinghua α -algorithm (Wen et al. 2004).
Heuristic-based	Heuristics Miner (Weijters and Van der Aalst 2003, Weijters et al. 2006)
Search-based	Genetic Algorithm Miner (De Medeiros 2006) Duplicates Genetic Algorithm Miner (De Medeiros et al. 2007).

Evaluation on various process mining discovery algorithms has been conducted. Van Dongen et al. (2009) compare some of the representative discovery algorithms on handling process constructs including sequence, parallelism, choice, loop, duplicate task, etc. Goedertier (2011) compares discovery algorithms' performance on accuracy, comprehensibility and justifiability.

3.2.2 Process Mining Applications

Process mining technique has been applied into real-life processes (e.g. Van der Aalst et al. 2007; Rozinat et al. 2008; Goedertier et al. 2011). Literature also shows that process mining has been applied to discover clinical pathways. Mans et al. (2008 and 2009) apply the Heuristics Miner algorithm to discover how stroke patients are treated in different hospitals and how care services are delivered to gynecological oncology patients in the AMC hospital in Amsterdam. The discovered process networks were confirmed by the staff of hospital, and also compared with an a priori flowchart of the process, with good results. Lang et al. (2008) studies the radiology workflows in the Erlangen University Clinic. During the study several control-flow mining techniques were evaluated. Authors conclude that α algorithm and the Multi-phase algorithm are not able to produce valid process models as these two

algorithms are severely affected by the incompleteness and noise present in clinical logs, while the Heuristics Miner algorithm and the Genetic Algorithm Miner produced the best results in the presence of noisy data. However, Gupta (2007) evaluates the Heuristics Miner algorithm in the healthcare domain. Gupta points out that the discovered process networks are generally spaghetti-like due to the complex and unstructured nature of healthcare processes. Such spaghetti-like pathways are not useful for understanding and further analysis.

Results of studies from Mans et al. (2008 and 2009) and Lang et al. (2008) demonstrate the applicability of Heuristics Miner algorithm to real clinical pathway identification. Heuristics Miner algorithm is particularly suitable to handle ubiquitous noise and incompleteness in event logs from healthcare. We also understand the limitations of the Heuristics Miner algorithm such as spaghetti-like process model. However, process mining has a great potential to facilitate understandings of clinical pathways and their variants. Thus, the Heuristics Miner algorithm is proposed in this study to identify patient-centered pathway.

3.3 Patient-centered Pathway Identification

Traditionally, medical prescription and treatment were conducted through physical symptoms observation, intuitive experimentation, and a process of trial-and-error. With the advancement of medical knowledge and technology, physicians are able to diagnose and deliver treatment with increasing accuracy and precision (Christensen et al. 2009). As we have discussed in Section 2.3, the medical and technological advancement enables precisely diagnosis by the cause of a condition rather than the symptom. When a disease can be diagnosed and treated in terms of precision medicine and empirical medicine, rule-based therapy is becoming

possible. Therefore, knowledge of an individual patient’s pathway can come from the medical records of other patients who have suffered from the same or similar conditions or come from the genetic information of the subject patient. In such situation, process mining can be applied to patient-centered pathway identification. A procedure is proposed and illustrated in Figure 3.2.

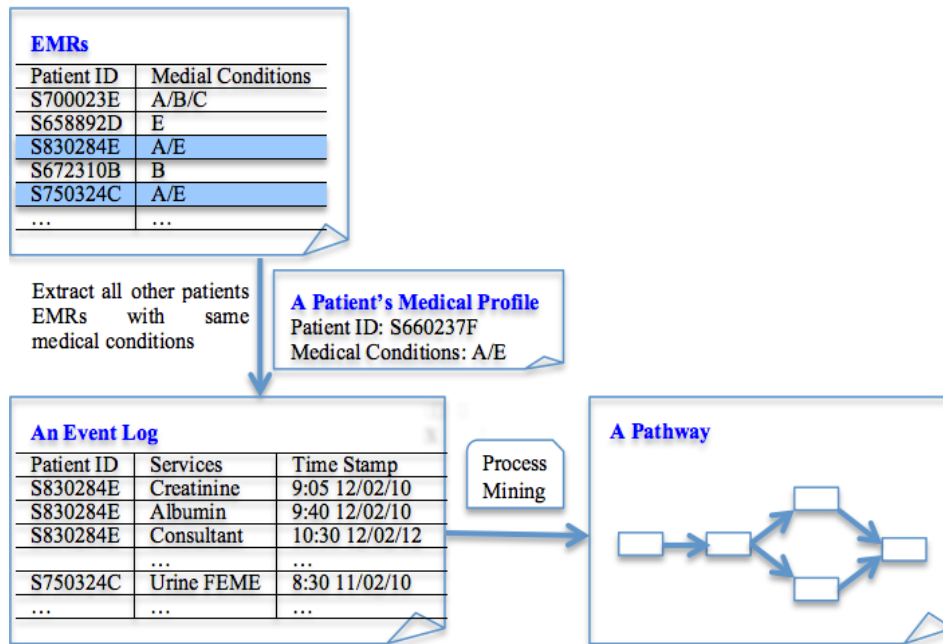

Figure 3.2: The procedure of pathway identification

EMRs of other patients with the same conditions are first extracted. Based on the extracted EMRs, the next step is to prepare an event log. Each individual patient’s overall journey is viewed as a process instance. A process instance typically contains information about activities with timestamp. In the context of healthcare, activities here refer to all kinds of healthcare services such as evaluations, diagnosis, and treatments received by a patient. Sometimes, a process instance also stores information about the originator of an activity, i.e. who performed which activity or initiated an event. After having an event log, process mining is used to distill pathways. More specifically, the Heuristics Miner algorithm is adopted in this study to

learn from the given event log. Activities' dependency relationships and process constructs are identified through analyzing the event log. Process networks are eventually discovered to represent clinical pathways. The process networks tell us how an individual patient with certain conditions most likely flow through the healthcare system. Notations and formulas used in the Heuristics Miner algorithm are defined by De Medeiros et al. (2007).

Notations:

A is a finite set of activities, i.e., $a_i \in A, i = 1, 2, 3, \dots, n$.

σ is an activity trace.

Σ is a set of activity traces, $\sigma \in \Sigma$.

W is an event log which is a multi-set of activity traces, $W \subseteq \Sigma$.

$a_i >_w a_j$ is a direct follower iff there is a trace $\sigma = a_1 a_2 \dots a_i a_j \dots a_n$.

$a_i >_w a_i$ is a length-one loop iff there is a trace $\sigma = a_1 a_2 \dots a_i a_i \dots a_n$.

$a_i \gg_w a_j$ is a length-two loop iff there is a trace $\sigma = a_1 a_2 \dots a_i a_j a_i \dots a_n$.

$D(a_i, a_j)$ is dependency ratio between activity a_i and activity a_j .

DM is dependency matrix.

The steps of the Heuristics Miner algorithm are explained in the following subsections.

3.3.1 Dependency Matrix Construction

The event log is a starting point of process mining. The first step is to analyze dependencies between activities. Let W be an event log over a set of activities A . Activity a_i and activity a_j are a pair of activities where $a_i, a_j \in A$. The dependency ratio $D(a_i, a_j)$ is defined to measure the strength of dependency between

activity a_i and a_j :

$$D(a_i, a_j) = \begin{cases} \left(\frac{|a_i >_w a_j| - |a_j >_w a_i|}{|a_i >_w a_j| + |a_j >_w a_i| + 1} \right) & \text{if } a_i \neq a_j \\ \left(\frac{|a_i >_w a_i|}{|a_i >_w a_i| + 1} \right) & \text{if } a_i = a_j \end{cases} \quad (3-1)$$

where

$|a_i >_w a_j|$ is the number of times that activity a_i is followed by activity a_j .

$|a_j >_w a_i|$ is the number of times that activity a_j is followed by activity a_i .

$|a_i >_w a_i|$ is the number of times that activity a_i followed by itself.

By introducing “+1” in the denominator, the $D(a_i, a_j)$ value of Eq. (3-1) and Eq. (3-2) is (-1, 1). In Eq. (3-1), if the value of $D(a_i, a_j)$ is close to 1, this means a strong positive dependency relation between activity a_i and a_j . In other words, for most of the process instances in the event log, it can be observed that activity a_i is followed by a_j most of the time rather than the other way around. If the value of $D(a_i, a_j)$ is approaching to -1, this simply means a negative dependency relation which is opposite to positive dependency relation. On the other hand, a zero value of $D(a_i, a_j)$ indicates a non-dependency relationship between activity a_i and a_j . The idea is similar for Eq. (3-2), a high absolute value of $D(a_i, a_j)$ shows a strong dependency relation and a zero value means no dependency relation between activity a_i and itself.

However, the dependency measurement presented above is not capable to deal with the repeated execution of activities. This is because the calculated value of $D(a_i, a_j)$ is always close to zero. The result may lead us to a wrong decision that

these two activities almost have no dependency relationship. Thus Eq. (3-3) is defined to handle the length-two dependency measure for activity in a loop.

$$D(a_i, a_j) = \left(\frac{|a_i \gg w a_j| + |a_j \gg w a_i|}{|a_i \gg w a_j| + |a_j \gg w a_i| + 1} \right) \quad (3-3)$$

where

$|a_i \gg w a_j|$ is the number of times that sequence of activity $a_i a_j a_i$ occurrence;

$|a_j \gg w a_i|$ is the number of times that sequence of activity $a_j a_i a_j$ occurrence

The basic idea of Eq. (3-3) is to measure total how many times that activity a_i is followed by a_j and activity a_j is followed by a_i can be observed from process instances in the event log among all co-occurrence between activity a_i and a_j . The more times we observed, the stronger dependency relationship between activity a_i and a_j .

Finally, a frequency-based Dependency Matrix (DM) is constructed to describe the dependencies between any pair of activities. A DM is a square matrix with identical column and row headings corresponding to the activities in the event log and entries in the matrix corresponding to the dependency ratio between a pair of activities (e.g. $D(a_i, a_j)$). Reading through a row reveals strength to its dependent activities.

3.3.2 Dependency Graph Construction

The construction of the dependency graph starts with the search in the DM . But the amount of information reflected on the graph is dependent on the parameter settings. The first parameter is “use all-activities-connected heuristic”. The “all-activities-connected” means that for each non-start activity there should be at

least one other activity as its input, while each non-final activity must have at least one dependent activity as its output. When constructing the dependency graph, the “start” activity is easy to recognize, which is the activity with a positive value in the row. In contrast, the “complete” activity is the row that has no positive entry. Next, we use “all-activities-connected” heuristic information to search for the “best candidate” in order to build correct relations (Weijter et al. 2006).

The other type of parameter is Dependency Threshold r , which indicates dependency strength between a pair of services. When searching for dependency graph, a parameter Dependency Threshold r is defined to control what activities and interrelationships are going to be included in the graph. Only those pairs of activities which dependency ratios $D(a_i, a_j)$ larger than r will be included. Based on the length between activities, the specific threshold parameters include:

- Direct Dependency Threshold: ignores the relationships whose direct dependency measurement is below the value of this parameter;
- Length-one Loop Dependency Threshold: means that a self-loop will be inserted if the value of corresponding measurement is above the value of this parameter;
- Length-two Loop Dependency Threshold: indicates that a length-two loop will be inserted if the value of measurement is above the value of this parameter.

The third parameter is Positive Observation. It means that the activity will be included in the process model if the observed times of activity occurrence is higher than the value of this parameter. The fourth parameter is Relative-to-best Threshold which compares a dependency ratio with the best dependency ratio in the DM . If the difference between them is smaller than the defined value of Relative-to-best Threshold, the dependency relationship will be shown in the process network. However, when we use the parameter “Use all activities-connected heuristic”, all

other parameters will have no effect on the graph construction. By varying parameters' input values, different analyses can be conducted. For this study, we only consider two types of parameter, namely "Use all-activities-connected heuristic" and "Dependency Threshold" as they are major factors to affect the result of process mining.

3.3.3 AND/XOR-split/join Constructs Identification

From the dependency graph, we are able to know each activity's input/output expression and dependency relationship. For a particular activity, however, if there is more than one activity in its input or output expression, the problem is the dependency relationship in between is not known. For a particular activity a_i , if it has two activities a_j and a_k in the input expression. The question is whether activities a_j and a_k are parallel activities. That is to say, before executing activity a_i , whether both activity a_j and a_k need to be done or only one activity needs to be done. If both activities need to be done, this relationship is called AND relationship. If only one activity needs to be done, this relationship is called XOR relationship. The semantics of the AND/XOR-split/join constructs are identified by Eq. (3-4).

$$a_i \Rightarrow a_j \wedge a_k = \frac{|a_j >_W a_k| + |a_k >_W a_j|}{|a_i >_W a_j| + |a_i >_W a_k| + 1} \quad (3-4)$$

The denominator $|a_i >_W a_j| + |a_i >_W a_k|$ calculates the number of positive observation that activity a_j or a_k directly follows activity a_i in the event log. The numerator $|a_j >_W a_k| + |a_k >_W a_j|$ counts the number of times a_j and a_k co-occurrence directly after each other. If the value of $a_i \Rightarrow a_j \wedge a_k$ is close to 1, activity a_j and a_k are in an AND-relationship. If the value is close to 0, activity

a_j and a_k are in an XOR-relationship. In a process model, there are some points that one flow could split into multiple flows and/or join into one flow later. These points are defined as split/join constructs in a process network. For example, AND-join means all activities before the join point need to be executed. XOR-join is a notation to choose only one activity among a number of activities to do that originates before the join point.

3.3.4 Process Model Evaluation

Process model evaluation is to assess the ability of the discovered process network to reflect the behavior observed in the event log. By comparing against the event log, evaluation is made mainly through three perspectives. The first is *fitness*. The purpose of fitness test is to exam how much of the behavior observed in the event log is reflected by the discovered process model. The second is *complexity*. A good process model is one that contains comprehensive information while understandable by the user. The complexity is generally indicated by the number of nodes or arcs in the discovered model. The last is *structure*. Due to data noise and low frequent process instances in the event log, the discovered process model should have a right balance between specificity and generality. The structure test is to exam how accurate the discovered model is by replaying observed behavior, and how general the discovered model is by allowing discover unobserved behavior. The process model evaluation is subjective. It depends on the problem that it exist in and also the user's requirement. But, a well-structured process model, in general, must be high in fitness, low in complexity and not over-specific or over-general in structure.

In Heuristics Miner algorithm, the discovered process model usually shows in a graphic form called Heuristic Net. The *Proper Completion* basically is to measure the

number of correctly parsed process instances over the total process instances in the event log. However, some process instances cannot be correctly parsed. Errors may occur when parsing or replaying process instances (Weijters et al. 2006). It is suggested to measure the fitness of the model by using the number of successfully parsed events (i.e. activities) rather than the number of successfully parsed traces. *Stop Semantics* is defined to measure the fitness of the discovered process model by replaying the process instances in the event log and stopping parsing whenever an error occurs. However, this is not a good fitness indicator due to the inability to determine if the parsing was stopped at the early stage or towards the end. To overcome this problem, another measure is proposed to measure the fitness by replaying a process instance in the event log and not stopping even problems are encountered. This measurement is known as *Continuous Semantics*. Based on the similar idea but extended to exam all process instances in the event log, *Improved Continuous Semantics* is defined to measure the fitness on a population of process instances rather than an individual process instance.

To determine the structural appropriateness, a conversion from the Heuristic net to a Petri net is required. A Petri net is a graphical representation of places and transitions. In a marked Petri net, circles indicate places in which tokens reside. And rectangles represent transitions (i.e. activities). Tokens are consumed to enable a firing of a transition expressing the execution of a particular activity. After firing a transition, new tokens are produced according to the process structure. Structure test is done by analyzing the behavioral appropriateness of tokens in a Petri net. When replaying a process instance σ in the event log on the discovered process model N , transitions need consume tokens for firing and produce tokens after transition been fired. Four different scenarios may encounter. $c_{N,\sigma}$ is the number of token consumed for firing a

transition. $p_{N,\sigma}$ is the number of token produced by successful fired transition. If tokens consumed to fire transitions ($c_{N,\sigma}$) are not produced by the Petri net itself but arbitrarily added to enable certain transitions. These added tokens are called missing tokens ($m_{N,\sigma}$). If produced tokens ($p_{N,\sigma}$) are not consumed by transitions, some tokens will be left in the Petri net when replaying is finished. These are called remaining tokens ($r_{N,\sigma}$). Both missing tokens and remaining tokens may lead to extra behaviors in a Petri net such as firing additional transitions. The token-based fitness $f_P(N,\sigma)$ is defined as in Eq. (3-5).

$$f_P(N,\sigma) = \frac{1}{2}(1 - m_{N,\sigma}/c_{N,\sigma}) + \frac{1}{2}(1 - r_{N,\sigma}/p_{N,\sigma}) \quad (3-5)$$

At the beginning of evaluation, $f_P(N,\sigma)$ is initialized as 1, which means a particular process instance in the event log can be replayed without any problem. In other words, there is no missing token added and no remaining token is left in the Petri net. By giving equal penalty to extra behaviors $f_P(N,\sigma)$ is calculated by deducting the sum of corresponding proportion from the initial value. The first part of Eq. (3-5) is $(1 - m_{N,\sigma}/c_{N,\sigma})$. It computes the number of missing token as a fraction of the number of consumed token. More missing tokens added to the Petri net, the value of $(1 - m_{N,\sigma}/c_{N,\sigma})$ will be smaller. A value close to zero indicates that too many missing tokens result in an extreme low fitness. The second part of the formula $(1 - r_{N,\sigma}/p_{N,\sigma})$ calculates the fraction of remaining tokens compared to tokens consumed. The idea is similar to the first part. More tokens left in the Petri net could result in a lower fitness. The Eq. (3-5) studies behaviors of replaying one process instance. To measure all process instances in the event log $W(\sigma)$, the following

fitness $f_L(N, W(\sigma))$ for the entire event log is defined as *Petri Net Fitness*.

$$f_L(N, W(\sigma)) = \frac{1}{2} \left(1 - \frac{\sum_{\sigma \in W} W(\sigma) \times m_{N, \sigma}}{\sum_{\sigma \in W} W(\sigma) \times c_{N, \sigma}} \right) + \frac{1}{2} \left(1 - \frac{\sum_{\sigma \in W} W(\sigma) \times r_{N, \sigma}}{\sum_{\sigma \in W} W(\sigma) \times p_{N, \sigma}} \right) \quad (3-6)$$

This formulation is similar to the definition of the fitness $f_P(N, \sigma)$ of each process instance in the way that it aggregates the fitness of all the process instances in the event log.

In summary, the flow of the Heuristics Miner algorithm is described in Figure 3.3.

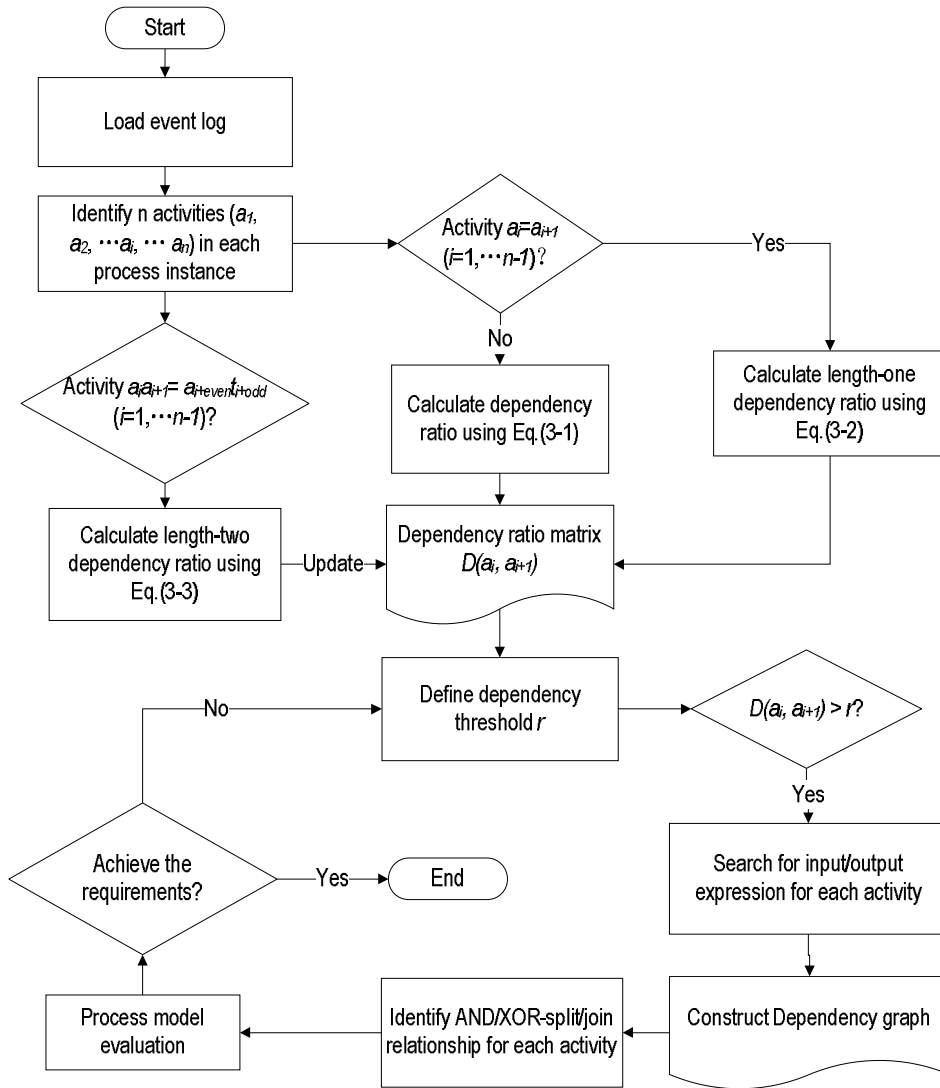

Figure 3.3: The Heuristics Miner algorithm flow chart

3.4 A Case Study of Patient-centered Pathway Identification

3.4.1 Case Background

Clinical pathways for patients with multiple conditions tend to be more complicated than patients with single condition. In addition, we need to look at the clinical pathway from a patient's point of view instead of the condition's point of view. In other words, what we need to know is how they flow through the healthcare system considering co-existing various conditions rather than isolated condition. In this case study, we will focus on patient-centered clinical pathway identification for patients with multiple conditions.

In Singapore, growing number of patients are suffering from combinatory of multiple conditions. We observed a prevalent trend of patients having both cardiovascular condition and ophthalmological problem from published statistics. Healthcare services delivered to those patients are generally based on standard disease-specific care pathways, which cannot fulfill their complex medical needs. They need for customized healthcare services. To enable customized healthcare service delivery, a key challenge is to understand the healthcare services that a patient with both cardiovascular and ophthalmological conditions needs to go through. Process mining provides a means to map required healthcare services onto medical conditions.

We collaborated with Tan Tock Seng Hospital (TTSH) to conduct this case study. TTSH is the second largest acute general hospital in Singapore. There are 36 clinical and allied health departments, 15 specialist centers covering 27 medical disciplines and is operated by more than 6,000 healthcare staff. EMRs of outpatients with cardiovascular condition and ophthalmological problem have been extracted from the information system. Specialist Outpatient Clinics (SOC) at the hospital during May of

2009. Appendix A gives a part of Excel file which depicts the information summarized from outpatients' EMRs given by TTSH.

These patients are identified by their identification number. Due to the confidentiality of the patient information, we use serial number to replace identification number. So, each patient is traced by the unique serial number. Surveys basically record the patient flow during every visit. In other words, main information includes what healthcare services have been delivered to a patient, which doctor a patient has visited, and how long each service takes etc. From the data, we find that patients have at least two times medical visits to SOCs in TTSH for cardiovascular condition and ophthalmological problem.

3.4.2 Event Log Extraction and Preparation

To identify patient-centered pathway, we look at the patient flow through the viewpoint of a patient instead of a condition/disease. That means each individual patient's overall journey is viewed as a process instance. As the scope of this case is to study patients with both cardiovascular condition and ophthalmological problem, information of 59 patients who are suffering both conditions is extracted from the survey data. An event log episode is shown in Table 3.2.

Table 3.2: An event log episode

Process Instance	Activities	Time Stamp (Start)	Time Stamp (End)
1	Registration	04-05-2009 11:04	04-05-2009 11:06
1	Eye Sight Test	04-05-2009 11:12	04-05-2009 11:16
1	1 st Eye Consultant	04-05-2009 11:43	04-05-2009 11:48
1	Humphrey Visual Field Test	04-05-2009 12:40	04-05-2009 14:43
1	2 nd Eye Consultant	04-05-2009 15:32	04-05-2009 15:37
1	1 st Cardiology Consultation	04-05-2009 15:45	04-05-2009 15:48
1	Billing and Payment	04-05-2009 16:00	04-05-2009 16:05
2	Registration	04-05-2009 15:08	04-05-2009 15:10
2	ECG	04-05-2009 16:20	04-05-2009 16:25
...			

In the event log, an individual patient's flow is viewed as a Process Instance identified by their identification number. The number being tagged to each Process Instance indicates a particular patient. For a Process Instance, the sequence of healthcare services that a particular patient has gone through is shown in the column named as Activities. The time attribute associating with each activity's starting and ending time is represented in the column Time Stamp (Start) and Time Stamp (End), respectively. Process in this study is defined as the care flow of all cardiovascular condition and ophthalmological problem patients. The number of patients is represented by the number of Process Instance in the event log.

The next step of event log preparation is to make the event log readable by the Process Mining Framework (ProM) software (Van der Aalst et al. 2007). The ProM reads log files in the Macromedia Flex Markup Language (MXML) format. The Mining function performs the actual process mining. To have the required MXML format, we first convert the event log in the Excel format into Comma-Separated Value (CSV) format. After that, the ProM Import Framework software is used to convert the event log from the CSV format into the MXML format. The event log is now ready for process network discovery using ProM software.

3.4.3 Process Network Discovery through ProM

For this study, different values for the dependency threshold will be used to show how different clinical pathways can be discovered. A process model is mined in the form of a Heuristic Net. The Heuristic Net shows activities' sequential relationship and AND/XOR-split/join structure. Each node in the Heuristic Net shows the name of the care service. The number in a node indicates the frequency of the service appears in the event log. The arc that connects two nodes shows the dependency relationship between two services. The first number on the arc indicates the value of dependency

ratio between services, while the second number indicates the co-occurrence frequencies. A process network is obtained by applying all-activity-connected heuristics shown in Figure 3.4.

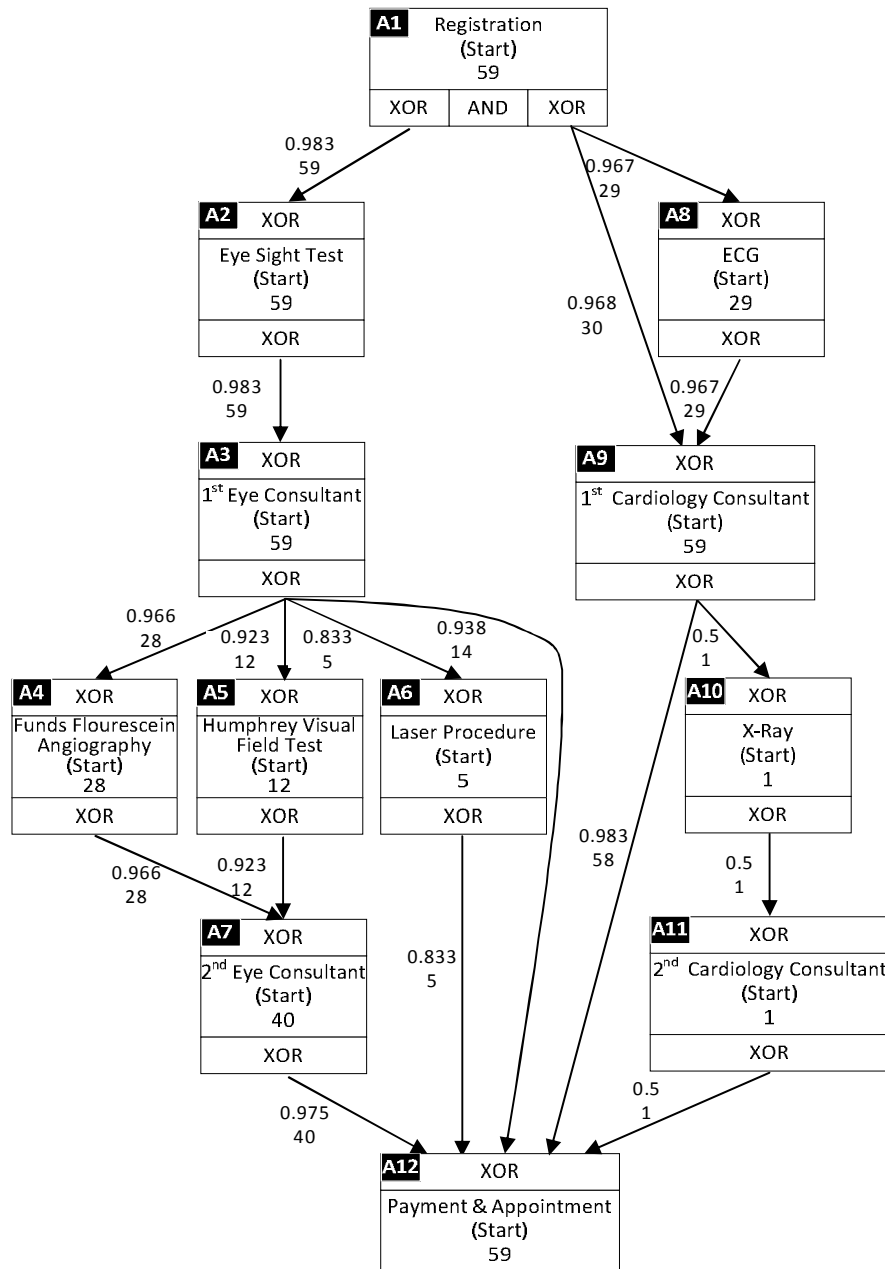

Figure 3.4: A heuristic net representation of process model with all-activity-connected

This model ignores the minimum dependency threshold requirement but includes all services in the event log into the discovered process network. In the network, node “Eye Sight Test” is followed by node “1st Eye Consultant” with the dependency ratio

0.983. As the value of dependency ratio is close to 1, it indicates there is a strong positive dependency relationship between these two healthcare services. That is to say “1st Eye Consultant” is pretty sure to be executed after service “Eye Sight Test” based on observation of the event log.

The Dependency Threshold parameter is one of the most important parameters in the Heuristics Miner algorithm as we have discussed in Subsection 3.3.2. We use it to demonstrate how varying parameter values can affect generated process networks. A series of generated process networks can be found in Appendix B with Dependency Threshold parameter from 0.95 to 0.8 decreased by 0.05 each time. Through observation, we found that as the value of the dependency threshold decreases, the process model become less compact and structural. This can also be explained by definition of Dependency Threshold as this parameter is defined to only include pairs of activities which dependency ratios are greater than its value in the process network. By setting different parameters at different values, health professionals are able to generate various process networks and find the most suitable one for patients with particular disease or combination of diseases.

3.4.4 Process Network Conformance

With the discovered Heuristic Nets, Fitness measurements defined in Subsection 3.3.4 are used to evaluate their ability to reflect behaviors observed in the event log. In addition, Heuristic Nets are converted into Petri Nets and shown in Appendix C. Petri Net Fitness measurement is applied to check the process structure and replay process instances. These measurements give us different perspectives for assessing the obtained process models. Table 3.3 shows the values of each process model.

Table 3.3: Fitness measurements for various process networks

Fitness Measurement	All-activity-connected	Dependency Threshold = 0.95	Dependency Threshold = 0.9	Dependency Threshold = 0.85	Dependency Threshold = 0.8
Proper Completion	0.5424	0.3431	0.4746	0.4746	0.4755
Stop Semantics	0.6061	0.5422	0.5620	0.5620	0.5730
Continuous Semantics	0.7118	0.6628	0.7006	0.7006	0.7260
Improved Continuous Semantics	0.9639	0.8572	0.9400	0.9400	0.9415
Petri Net fitness	0.9723	0.9137	0.9666	0.9666	0.9666

We observed that the process network using all-activity-connected heuristics has the highest fitness values in all measurements. This indicates that the discovered process network is able to closely reflect information observed in the event log by ignoring all variable parameters. The reason is mainly because the all-activity-connected process network does not exclude any observed event in the log. We also noticed that a lower dependency threshold results in higher conformance level as more services and interrelationships are included in the process network. There is a trade-off between the dependency threshold value defined and the goodness of the discovered process model.

The discovered process network basically is what we called the patient-centered clinical pathway in this study. It tells us what healthcare services that a patient with both cardiovascular condition and ophthalmological problem most likely to go through. In other words, the discovered clinical pathway establishes the matching between a patient's medical profile and the care services required.

3.5 Summary

In summary, this chapter evaluated the application of process mining on patient-centered pathway identification. Heuristics Miner algorithm is applied to extract the underlying structures of process networks which reflect pathway variants.

Various process networks are generated by varying the dependency threshold levels in the case study. Fitness measurements are used to compare the results of mined process networks. It is found that all-activity-connected heuristics network achieves the highest fitness values in all measurements.

The results of case study demonstrate that process mining is able to present most behavior observed in the event log in the process network. The proposed method is promising in terms of identifying well-structured pathways to establish the mapping from individual patients' medical needs to diversity of healthcare services.

CHAPTER 4 MODULAR HEALTHCARE PROCESS REDESIGN USING DESIGN STRUCTURE MATRIX

Modularization is an important approach to reduce process complexity and enhance flexibility in manipulating pre-identified service modules. This chapter introduced DSM technique for healthcare process modularization. In Section 4.3, a DSM-based modularization and sequencing algorithm is developed to allocate healthcare services into service modules using GA and enumerate all possible sequences of services within a module and sequences of modules to support modular clinical pathway redesign. The proposed algorithm is implemented in the same case as in Chapter 3. The redesigned modular clinical pathway is visualized in a process network diagram.

4.1 Motivation for Process Modularization

Modular product architecture has been seen as a good way for low cost and efficient product design in mass customization. Standard modules can be mass produced in large batches and be configured according to customer's requirements. Although the modularity principle originates from the manufacturing industry, it has been used for complex process design in services (e.g. Meyer and Detore 1999 and 2001; Pekkarinen and Ulkuniemi 2008; Moon et al. 2009 and 2011; Xu and Jiao 2009a and 2009b). Process modularity is similar but it refers to the practice of standardizing process modules. Pine (1993) pointed out that the traditional tightly coupled production processes should be broken apart and modularized. Modules in processes are able to be adjusted easily by adding, removing or re-sequencing to create different process capabilities (Cooper 1999). The flexibility of modular process delivery is able to enhance customization.

The process model generated through process mining is a direct reflection of what patients have historically gone through. Although the process model helps to uncover the mapping relationship between individual patients' medical profile and required healthcare services, it might be very complicated and unstructured due to large variety of healthcare services offering and different combination of medical conditions. Spaghetti-like pathways are hard to comprehend and apply in practice (Bose and van der Aalst 2009). The significance of introducing modularization into mass customization of healthcare services manifests in two major aspects. Firstly, modularization facilitates process complexity reduction by grouping closely interacted healthcare services into modules. Secondly, modularization enables better-coordination flexibly combining modules to fulfill diversified medical needs.

From a system's point of view, modularization breaks up loosely linked healthcare services and arranges them into modules that can great reduce complexity and be performed rather independently. With modular healthcare processes, patients can have better-coordinated care by flexibly combine multiple modules that suit his/her conditions. First steps on healthcare process modularity and platform design have been made (e.g. McLaughlin and Kaluzny 2000; Bohmer 2005; Bohmer and Lawrence 2008; De Blok et al. 2010). However, further researches are needed to develop rigorous approaches for process module identification and process configuration.

4.2 Design Structure Matrix

The DSM is a matrix representation of a graph with identical column and row headings corresponding to the nodes of the graph and entries in the matrix corresponding to the arrows in the graph illustrate presence or absence of a

relationship between pairs of elements (Eppinger et al. 1994, Browning 2001, Yassine 2004). Thus DSM is a compatible way to represent architecture of the discovered clinical pathway in Chapter 3 as the discovered pathway describes mainly about dependencies between pairs of healthcare services. In addition, matrix representation is able to overcome the size and visual complexity of the graph-based clinical pathway and is amenable to computer manipulation.

The DSM has seen considerable use for process-modeling as well as applications associated with modular design (Eppinger et al. 1994; Whitfield et al. 2002; Yassine 2004). Studies have been conducted in many domains such as process decomposition and project management through developing DSM-based algorithms (Eppinger et al. 1991; Steward 1991). These studies established a foundation for us to use the DSM as a tool for modules identification in a clinical pathway.

The DSM generally can be categorized into two types: static DSM and time-based DSM (Browning 2001). Static DSM represents simultaneously existing elements, such as components of a product or teams of an organization. Time-based DSM models interdependent elements, such as activities in a process network or a document of an information flow. In the time-based DSM, the ordering of the rows and columns indicates a sequence over time. An off-diagonal entry implies the “feedforward” dependency of one element on another. An upper-diagonal entry signifies the “feedback” relationship between a pair of elements. Activity-based DSM is a branch of time-based DSM which is used for modeling process and activity networks based on activities. An activity-based DSM captures the input and output relationships between activities and describes the dependency structure of a process model based on information flow. In a process, information is generated, used and transferred associated with each activity. The quality of any process lies in effective

communication and data exchange across activates. When requisite information or output from other elements is not available to execute a particular activity, the arrival of information or change of output will lead to rework (Denker et al. 1999; Browning 2001). This kind of information or output is called a feedback and shown as an upper-diagonal entry in an activity-based DSM. For a complex process, rework is costly and risky, especially the healthcare delivery process dealing with people's body or mental health.

Once a process model is mapped to a DSM, analysis and improvement of the process can be conducted to minimize feedback by re-sequencing rows and columns. The widely-practiced algorithms are called partitioning and tearing. Partitioning is to re-sequence the tasks to maximize the availability of information required at each stage in the process (Steward 1981; Kusiak and Wang 1993). The procedure of partitioning is to manipulate the sequence of rows and columns to make the DSM into a lower triangular form or as a block along the main diagonal of DSM. A number of studies have been conducted on developing partitioning algorithms. Path searching algorithm is first proposed by Compare Gebala and Eppinger (1991). The procedure of partitioning may be undertaken through trial and error approach and the results are very dependent on expertise. More systematic computer-based approaches have been developed for complex processes such as application of GA and simulation. Rogers et al. (1999) propose to apply GA to optimize the sequence of the process flow within iterative sub-cycles to reduce design cycle time and cost. The algorithm is developed to re-sequence the activities in a DSM aimed at minimizing the number of feedbacks above the diagonal. Scott (1999) also makes use of GA to re-sequence the activities based on DSM to minimize the number of feedbacks with particular focus on concurrency issue. In addition, simulation-based approaches have been proposed by

McCulley et al. (1997) and Cho and Eppinger (2005). Partitioning results in a lower matrix or a block diagonal matrix in the case of coupled activities. Ideal sequencing without feedback entries is unlikely to exist. Thus, coupled activities within a loop require additional reordering algorithms. Tearing is a process with the aim of removing feedback marks (Kron 1963). Tearing is typically to be conducted manually by professionals with domain knowledge.

The goal of modularization is to find a clustering arrangement where modules minimally interact with each other while elements within a module maximally interact with each other (Fernandez 1998). In other words, these identified modules absorb most of the interactions between elements internally and the interactions between modules are minimized or even eliminated. Modularization related research has developed mainly in the areas of product and service architecture. Product architecture is to arrange functional elements/components into physical modules for a product or for a family of products. Modularization is generally achieved by applications of clustering techniques. Jain et al. (1999) and Xu and Wunsch (2005) give a comprehensive review of clustering algorithms and approaches. Pimmler and Eppinger (1994) use DSM to reorder elements with an algorithm that optimizes a distance penalty. Fernandez (1998) and Thebeau (2001) used the simulated annealing technique to find good DSM clustering arrangements. Advantages of modular product architecture show in aspects of simplicity and reusability.

Modularization is also increasingly recognized in service industries as a cost-effective way to support process design and management (e.g. Sundbo 1994; Pekkarinen and Ulkuniemi 2008; Moon et al. 2009). For example, a modular service platform for business services has been developed in the paper of Pekkarinen and Ulkuniemi (2008). Research concerning strategic healthcare process design and

delivery by applying modularization has been found in recent literature (e.g. Bohmer 2005 and 2008; Meyer et al. 2007; De Blok et al. 2010).

4.3 Modular Healthcare Process Redesign

The redesign of healthcare process in the DSM requires several considerations. The primary objective of modularization is to maximize interactions between services within modules while minimizing interactions between modules. The second issue is to identify the sequence of modules to minimize feedback information in order to streamline the modularized clinical pathway.

Professional care services are linked with technical constraints as a whole in a clinical pathway through the information transition, resource sharing and people interaction. Four important dimensions regarding clinical pathway modularization are *events, components, modules, and interfaces*. The definition is similar to what De Blok et al. (2010) and Perters and Saidin (2000) stated. A care service, which aims to achieve a clearly defined purpose or function, is viewed as a process component (i.e. tissue testing and X-ray examination). A process component may contain a single event or a combination of several events to gain particular ends. A module is a cluster of two or more components that closely interact or inter-depend with each other to assist clinical decision making such as a serial of pre-examinations associated with an operation. Interfaces are interactions or interdependencies between components. Generally, the strength of interaction is a key factor to affect the size of service modules. Strongly interacted services are grouped into a module. A clinical pathway with combination of different healthcare service components and/or service modules is referred to a modular clinical pathway. Combining and connecting various components or modules by means of interfaces creates a healthcare service package

offered.

This research develops a process modularization and sequencing approach based on DSM, which groups care services with strong interactions into modules and adjusts the sequence of modules to minimize feedback in the process. Due to the particularity of healthcare delivery, the feasibility of care modules identified and sequences of modules in the clinical pathway are evaluated by the health professional from medical and operational perspective. In this thesis, the words module and cluster can be interchanged without changing the context's meaning.

4.3.1 Healthcare Process Modularization and Sequencing Formulation

We aim to model the total coordination cost in order to decide which services can be grouped together. In a healthcare delivery process, individual care service needs to be performed as a part of a whole. To manage coordination between care services is difficult or costly. The cost of managing coordination increases associated with the number of services included in a process. Moreover, the cost of managing coordination is also affected by the strength of interaction between services. Closely interacted care services within a module are easy to manage because originators or performers (e.g. doctors, nurses, and technicians) can work efficiently through collective planning, quick communication and joint delivery. It is generally believed that the cost of coordination is lower within a module but higher across modules. As the number of interaction and the strength of interaction between modules increase, delays or errors are more likely to occur due to waiting for information from other modules. Thus, the inter-module coordination should be relatively weak by putting loosely interacted care services in different modules. The total coordination cost is defined to capture both. Based on the total coordination cost, the major steps in modular healthcare process redesign are: 1) Cluster activities into modules; 2)

Generate sequences of services in modules and sequences of modules; and 3) Identify feasible sequences for redesign.

The clustering approach that we present in this study is inspired by the work of Thebeau (2001). In his thesis, two problems are addressed to deal with tasks performed in a product development project. The first problem is to “identify the set of interdependent tasks” and the second one is to “group project tasks into clusters that are loosely connected with each other, while each cluster consists of densely connected inter-coupled tasks”. Interdependencies between tasks are quantified and captured in a DSM. To determine clusters, an algorithm based on simulated annealing is proposed to decrease the value of a total coordination cost function iteratively. It was Thebeau (2001) who introduced the notion of coordination cost function to evaluate different clustering arrangements within DSM. Even though no prior knowledge on the number and the size of clusters are available, the total coordination cost can effectively measure the strength of interdependencies of activities within or between clusters. Due to this reason, the total coordination cost function is used as a basis for healthcare service modularization.

The *DSM* in this study is a square matrix with identical row and column headings corresponding to the nodes (i.e. healthcare services) in the process network which is discovered in Chapter 3. Entries in *DSM* are corresponding to the dependency ratio on arrows in the discovered process network. The entries illustrate the presence or absence of a relationship between a pair of healthcare services. In addition, the entries indicate the strength of interdependency between a pair of services. Interrelationship and strength of interrelationship in the *DSM* provide a means of process analysis.

We developed a GA-based modularization algorithm and extended Thebeau’s

work to solve re-sequence problem for healthcare service modules. Notations used in the algorithm are defined as follow:

Notations:

- DSM is the DSM representing the discovered clinical pathway.
- a_i, a_j is the activity a_i and a_j in the matrix.
- $DM(i, j)$ is the dependency value between activity a_i and a_j .
- TCC is the total coordination cost.
- $CC(a_i)$ is the coordination of a_i with respect to all other activities.
- $size$ is the size of DSM which indicates the number of activities in DSM .
- $size(k)$ is the number of activities in the cluster k .
- pow_c is a parameter indicating the penalty assigned to the size of the cluster.
- TFB is the total feedback of all clusters.
- $FB(l)$ is the feedback of cluster l .
- DSM_{cl} is the compressed DSM by clusters.
- $size_{cl}$ is the size of DSM_{cl} which indicates the number of clusters in DSM_{cl} .
- fb_num is the number cells containing feedback.
-

For each service a_i in DSM , we calculate $CC(a_i)$ considering interrelationships between a_i and all other services. For any pair of service a_i and a_j . The cost is calculated using entries (i.e. dependency ratios) in the DM and the size of a cluster which includes both activates. There are two situations that both service a_i and a_j are either in a cluster k or not. The size of the cluster is decided by either the number of services in cluster k or the number of services in the DM . The summation of the coordination cost of each service gives a total coordination cost for the whole clinical pathway. So, the objective is to minimize TCC .

$$\text{Minimize } TCC = \sum_{i=1}^{size} CC(a_i) \quad (4-1)$$

where

$$CC(a_i) = \begin{cases} \sum_{j=1}^{size} (DSM(a_i, a_j) + DSM(a_j, a_i)) * size(k)^{pow-c}, & \text{if } a_i, a_j \in k. \\ \sum_{j=1}^{size} (DSM(a_i, a_j) + DSM(a_j, a_i)) * size^{pow-c}, & \text{if } a_i, a_j \notin k. \end{cases} \quad (4-2)$$

$$\sum_{j=1}^{size} (DSM(a_i, a_j) + DSM(a_j, a_i)) * size^{pow-c}, & \text{if } a_i, a_j \notin k. \quad (4-3)$$

If both service a_i and a_j belong to the same module k . Eq. (4-2) is defined to calculate the coordination cost for service a_i . If no cluster contains both service a_i and a_j , the entire DSM acts as a whole to contain both of them. And the coordination cost for service a_i is computed using Eq. (4-3). In Eq. (4-2) and Eq. (4-3), we introduce a parameter pow_c as a control parameter indicating the penalty assigned to the size of the module. Through introducing pow_c parameter, we are able to control the size of each module not too large or too small. The default value of pow_c is 1. If the value of pow_c increases, $CC(a_i)$ will increase exponentially to limit the module size. After finding the minimum TCC , we are able to know what services are grouped together into a cluster k and the total number of clusters.

The next step is to arrange these identified modules in sequence to maximize the availability of information required by each cluster in the process. So, interrelationship between healthcare services within a cluster will temporarily not be taken into consideration. The DSM is compressed by clusters into a DSM_{cl} . Basically, DSM_{cl} captures the interactions between clusters while treats interactions between services within a cluster as a whole. DSM_{cl} is a time-based DSM with $size_{cl}$ number of clusters.

The healthcare process is characterized by highly interdependent healthcare services. If a healthcare service begins to work without necessary information, the arrival or change of that information will cause rework believably due to poor service sequencing or lack of coordination. Rework is costly and risky, especially in the healthcare delivery process dealing with people's body or mental health. The unavailable information in a time-based DSM is indicated by the feedback entries in the up diagonal. In this study, the cluster sequencing basically is to re-sequence clusters in order to eliminate or reduce the feedback entries by minimizing TFB . TFB is the summation of each cluster's feedback $FB(l)$ multiplied by the number of feedback marks fb_num . We take the number of feedback marks into consideration because more cells containing feedback marks means more unavailable information required. More unavailable information may lead to more re-execution of care services. For a particular cluster l , $FB(l)$ is calculated by Eq. (4-5), which is the summation of entries in the upper diagonal of DSM_{cl} .

$$\text{Minimize } TFB = \sum_{l=1}^{size_{cl}} (FB(l) * fb_num) \quad (4-4)$$

where

$$FB(l) = \sum_{l=1}^{size_{cl}} \sum_{m=l+1}^{size_{cl}} DSM_{cl}(l, m) \quad (4-5)$$

If feedback marks exist in a particular service module, the above defined equations for TFB and $FB(l)$ can also apply to calculate total feedback of the module by changing $size_{cl}$ to the size of the module.

In summary, service modules are identified by minimizing the clinical pathway's total coordination cost. Strongly interacted care services are grouped into the same

module while loosely interacted services are grouped into different modules. Identified modules are sequenced to find minimum total feedback information. This procedure helps to better streamline care modules through reducing feedback entries.

However, not every sequence is feasible if we consider the precedence relationship between care services. Health professional knowledge is necessary to carefully review and re-sequence healthcare service modules. The outcome of redesigned clinical pathway is in a form of modular process.

4.3.2 A New Modularization and Sequencing Algorithm

To redesign a clinical pathway into a modular clinical pathway, a new algorithm is needed to not only group closely interacted healthcare services into modules but also re-sequence identified modules to streamline the process. This problem is essentially a combinatorial optimization problem with discrete nature, while GA is reported with excellent performance in a combinatorial problem. Thus, we develop a GA-based modularization and sequencing algorithm to support healthcare process redesign.

For a combinatorial problem, the difficulty grows exponentially as problem size increases known as a NP-complete problem. A rich number of techniques have been developed by researchers to solve the including exhaustive search techniques, heuristic-based search techniques and random-based search techniques. The global optimum can be guaranteed by mathematical approach (e.g. branch-and-bound search) and enumeration. However, exhaustive search leads to large amount of computer processing time. Applying techniques based on heuristics (e.g. greedy heuristics) is fast in computation to search in solution space. However, in a large search space, the issue is that the search always moves towards the nearest favorable regions. A local optimum with a high probability tends to be obtained rather than a global optimum.

Applying random-based search techniques is able to jump out of local optimum regions and converge at a global optimum region. However, a purely random search technique consumes a large amount of computational efforts even though it can find the global optimum by chance. Thus, some random-based directed search techniques have been developed to explore better solutions through directed search such as GA. GA is a search heuristic, which uses techniques inspired by natural evolutionary process (e.g. selection, crossover and mutation) to generate solutions. GA is pioneered by Holland and his students (1975). GA is more effective and efficient than purely random-based algorithms. The GA-based technique has been tested on various sized problems and proved to achieve good solutions in discrete optimization problems (Goldberg 1989).

A GA-based procedure is proposed to allocate healthcare services into clusters with the lowest *TCC*. Then, enumeration is used to find all possible sequences of clusters with minimum *TFB* to support modular clinical pathway redesign. The flowchart of the algorithm is show in Figure 4.1.

After loading data from *DSM* and setting parameter *pow_c* value, a modified GA is applied in the first part of the proposed algorithm. Key elements in the GA algorithm design are explained in the following paragraphs.

Traditionally, a binary individual encoding is used with the GA. The values of parameters are represented by a string of 0 and 1 and then concatenated. The binary coding has the advantage of simplicity in gene representation. However, when dealing with the modularization problem, a concatenation of binary numbers to represent an activity tends to be inadequate. This is because new individuals can be easily created

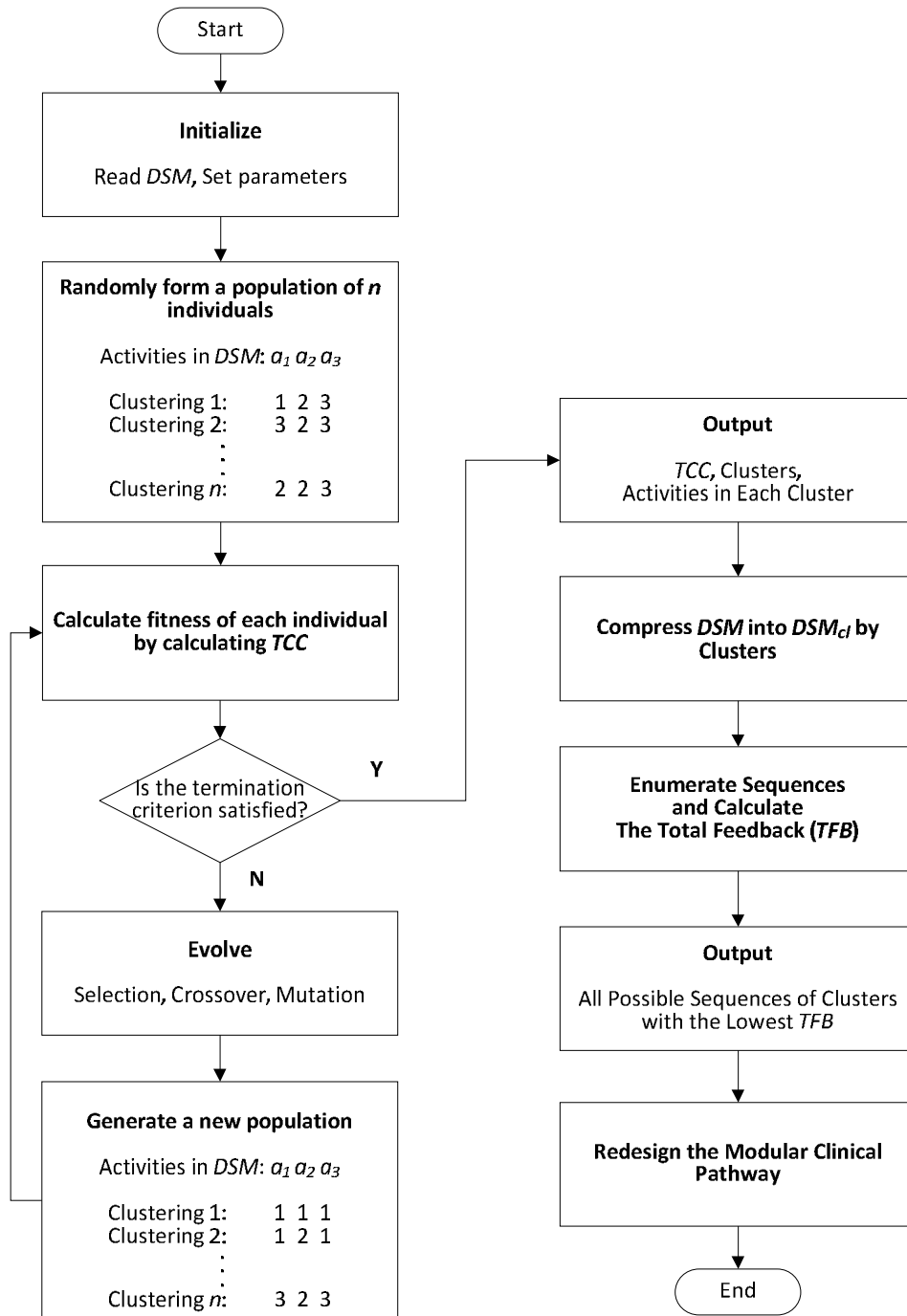

Figure 4.1: A GA-based modularization algorithm

to contain some of the activities more than once while some other activities not at all. In this study, we modify the individual encoding such that an individual is represented by a sequence of n integers within which the i th position can range from 1 to n . n is equal to the number of healthcare services in DSM . The digit at the i th

position represents the corresponding service belongs to which cluster. The modified encoding approach enables not only the application of common crossover and mutation operators but also the elimination of prior knowledge on the number of modules. An illustrative example of individual encoding is shown in Figure 4.2.

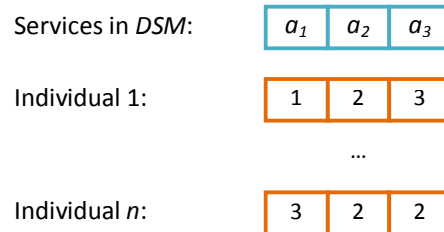

Figure 4.2: Individual encoding for modularity

Individual 1 represents that three services are allocated to three different clusters with cluster tag 1, 2 and 3 respectively. Individual n , the last individual in this population, indicates that service a_2 and a_3 are in the same cluster, while service a_1 in a different cluster with tag 3. Totally three services are grouped into two clusters. The digit at each position is randomly chosen from the range between 1 and the number of services. In other words, there is at least one cluster containing all services in *DSM* if all services are with the same cluster tag. The maximum number of clusters is as many as the number of services in *DSM*. This situation happens when each cluster contains only one service.

Based on this kind of individual encoding, an initial population containing a set of potential solutions is randomly generated. Each individual's fitness value is evaluated by calculating *TCC*. If it converges insufficiently, a population will evolve by selecting the fitter individuals and generating new individuals. The roulette wheel is used to select individuals with bigger fitness value have a greater probability to be selected as parents to contribute offspring in the next generation.

Once fit individuals have been selected in to a mating pool, pairs of individuals in the mating pool are randomly selected and altered in hopes of improving their fitness for the next generation. The single-point crossover operator is applied. In single-point crossover, a random crossover point on the two individuals is set. This refers to the crossover rate or probability. One individual contributes its entire genes before that point and the other contributes its entire genes after that point to produce an offspring. When the crossover does not occur, the two parents are transferred to the child population unchanged. After a crossover is performed, the mutation operator is applied to change randomly one gene to another. Each gene has a user-specified mutation probability to be mutated. So mutation in GA causes small alterations in an individual. This operator helps to maintain genetic diversity and avoids falling into a local optimum.

The fitness value of each individual in the new generation is evaluated. And the above mentioned evolution procedure will repeat for many iterations until the average fitness of the population converges. The outcomes are number of clusters, services in each cluster, and *TCC* value. Thus, healthcare services in *DSM* are clustered into mutually interacted service modules. If we treat dependency relationship between healthcare services within a cluster as a whole, the original *DSM* can be compressed into DSM_{cl} by emphasizing interrelationships between modules.

The second part of the proposed algorithm is to re-sequence identified service modules to find all possible sequences with minimum *TFB* through enumeration. The result of commonly used partitioning and tearing algorithms in *DSM* is one good sequence with minimum feedbacks instead of all possible sequences. In the clinical pathways re-design, a comprehensive understanding of all possibilities is essential. The re-sequence procedure also applies to decide the order of healthcare services if

feedback marks exist within a module.

Finally, we can redesign clinical pathways into modular clinical pathways considering possible sequences of modules, sequences of healthcare services in a module, technical constraints (e.g. precedence constraint) and medical knowledge. The redesigned modular clinical pathway is with great simplification for further analysis and application.

4.4 A Case Study of Modular Healthcare Process Redesign

In Section 3.4, we discovered patient-centered clinical pathways for patients with both cardiovascular condition and ophthalmological problem. Based on the discovered pathways, the method proposed in Section 4.3 is applied for process redesign. For the sake of comprehension of the information in the event log, the all-activity-connected process network (shown in Figure 3.4) is used as a basis for clinical pathway redesign.

4.4.1 DSM Representation of the Clinical Pathway

Dependency relationship and strength of interdependencies between pairs of healthcare services are captured in *DSM* shown in Table 4.1.

Table 4.1: The *DSM* of all-connected-activity process network

		From											
		A1	A2	A3	A4	A5	A6	A7	A8	A9	A10	A11	A12
To	A1	0	0	0	0	0	0	0	0	0	0	0	0
	A2	0.983	0	0	0	0	0	0	0	0	0	0	0
	A3	0	0.983	0	0	0	0	0	0	0	0	0	0
	A4	0	0	0.966	0	0	0	0	0	0	0	0	0
	A5	0	0	0.923	0	0	0	0	0	0	0	0	0
	A6	0	0	0.833	0	0	0	0	0	0	0	0	0
	A7	0	0	0	0.966	0.923	0	0	0	0	0	0	0
	A8	0.967	0	0	0	0	0	0	0	0	0	0	0
	A9	0.968	0	0	0	0	0	0	0.967	0	0	0	0
	A10	0	0	0	0	0	0	0	0	0.5	0	0	0
	A11	0	0	0	0	0	0	0	0	0	0.5	0	0
	A12	0	0	0.938	0	0	0.833	0.975	0	0.983	0	0.5	0

Notes:	
A1 Registration	A7 2 nd Eye Consultant
A2 Eye Sight Test	A8 ECG
A3 1 st Eye Consultant	A9 1st Cardiology Consultation
A4 Fundus Flourescein Angiography	A10 X-ray
A5 Humphrey Visual Field Test	A11 2nd Cardiology Consultation
A6 Laser Procedure	A12 Bill & Payment

The *DSM* is a square matrix with identical row and column headings. Column and row headings A_1 to A_{12} are corresponding to the nodes (i.e. healthcare services) in the all-activity-connected process network (shown in Figure 3.4). Descriptions of headings can be found from the notes of the *DSM*. The entries in the *DSM* corresponding to the arrows in the process network illustrate presence or absence of a relationship between a pair of healthcare services. For example, if there is an arrow from node A_1 to node A_2 with dependency ratio 0.983 on the arrow, then 0.983 is placed in the cell of column A_1 and row A_2 . Reading through a column reveals the outcome or information of the healthcare service in this column affects what healthcare services else and their strength. Off-diagonal entries signify the feed forward dependency relationship of one healthcare service to another, while upper-diagonal entries imply the feedback dependencies. For example, healthcare service A_2 provides something to healthcare service A_3 , while it depends on something from healthcare service A_1 . Obviously, healthcare services A_1 , A_2 and A_3 are in sequence.

4.4.2 Results of Modularization

When applying the proposed modularization and sequencing algorithm (refer to Subsection 4.3.2, the Matlab code of the algorithm can be found in Appendix D) to the case study, parameters in the GA are factors to affect the result of modularization. Design of Experiments (DOE) technique provides a means to simultaneously gain

insight into the individual and interactive effects of these factors on the result. Therefore, a 3^3 full factorial experiment with factors Population Size, Crossover Rate, and Mutation Rate is used to test which parameters significantly affect the response variable and determine the parameters values. Detailed description of the experiment is included in Appendix E. The values of the GA parameters are selected to be Population Size = 100, the Crossover Rate = 0.5 and the Mutation Rate = 0.1.

With different parameter settings the healthcare services are clustered into different service modules. Results of modularization can be found in Appendix F. For example, the lowest TCC at 82.864 can be achieved by clustering 12 healthcare services A_1 to A_{12} into 4 service modules with module tag from Module 1 (i.e. M_1) to Module 4 (i.e. M_4). The number of modules and value of TCC with respect to the parameter pow_c are displayed in Figure 4.3. The solid line describes the change on number of modules affects TCC when $pow_c = 1$, while the dashed line describes the relationship when $pow_c = 2$.

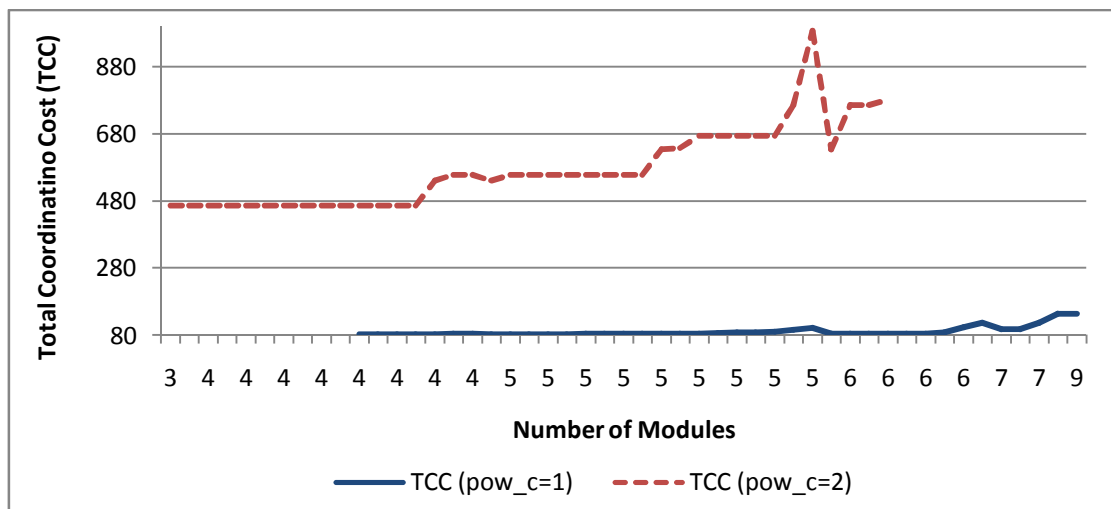

Figure 4.3: Effect of number of modules on TCC

If we looked at the solid line relative to the horizontal axis, it is found that the number of modules when $pow_c = 1$ ranges between 4 and 9. This means that the

Through observation we found that larger Population Size results in smaller variance on TCC and closer value to the minimum TCC no matter the value of pow_c . This indicates that the GA performs better with larger Population Size mainly because that large population provides a sufficient sample size. However, there is no reduction on TCC with Population Size from 150 to 200. This means that there is no need to have a very large population size when actually implementing the algorithm.

We shared our findings with relevant institutions and health professionals in order to seek advice on a proper process modularization for this case study. From the clinical practice's point of view, professionals suggested to select the process module structure shown in the 2nd column of Table 4.2 although its TCC is not the minimum value 82.864. During discussions, we understood that A_6 is a clinical procedure which is performed by licensed doctors. Before proceeding to the procedure, eye sight test and doctor consultation (namely A_2 and A_3) are compulsory to go through. During the procedure, the patient's conditions have been examined and 2nd consultation is not necessary to have. However, services A_4 and A_5 are two medical tests. Results are required to be reviewed by the doctor for decision making on further medical treatment, medication or follow-up visits. It is more practical and operational to cluster services A_4, A_5, A_7 and A_2, A_3, A_6 into two different service modules rather than put them all together into one module.

Table 4.2: The comparison of healthcare services in each module

Module Tag	The selected module structure	The lowest TCC module structure
M_1	$A_4 A_5 A_7$	$A_2 A_3 A_4 A_5 A_6 A_7$
M_2	A_{12}	A_{12}
M_3	$A_2 A_3 A_6$	A_1
M_4	A_1	$A_8 A_9 A_{10} A_{11}$
M_5	$A_8 A_9 A_{10} A_{11}$	-
TCC	83.302	82.864

Total 12 healthcare services in the clinical pathway are clustered into 5 modules. Each module contains no more than 4 healthcare services. Healthcare services in the clinical pathway have been clustered into mutually interacted healthcare service modules for patients with both cardiovascular and ophthalmological conditions. The *DSM* representation of modules is given in Table 4.3. Healthcare services within a module are shaded.

Comparing to the original *DSM* shown in Table 4.1, the sequence of healthcare services has been adjusted in order to put services in a module together. The adjusting of healthcare services' sequence leads to the occurrence of feedback entries on the upper-diagonal cells.

Table 4.3: The *DSM* representation of modules

		From											
		A4	A5	A7	A12	A2	A3	A6	A1	A8	A9	A10	A11
M1	A4	0	0	0	0	0	0.966	0	0	0	0	0	0
	A5	0	0	0	0	0	0.923	0	0	0	0	0	0
	A7	0.966	0.923	0	0	0	0	0	0	0	0	0	0
M2	A12	0	0	0.975	0	0	0.938	0.833	0	0	0.983	0	0.5
M3	A2	0	0	0	0	0	0	0	0.983	0	0	0	0
	A3	0	0	0	0	0.983	0	0	0	0	0	0	0
	A6	0	0	0	0	0	0.833	0	0	0	0	0	0
M4	A1	0	0	0	0	0	0	0	0	0	0	0	
M5	A8	0	0	0	0	0	0	0	0.967	0	0	0	0
	A9	0	0	0	0	0	0	0	0.968	0.967	0	0	0
	A10	0	0	0	0	0	0	0	0	0	0.5	0	0
	A11	0	0	0	0	0	0	0	0	0	0	0.5	0

4.4.3 Results of Sequencing and Redesign

By emphasizing interrelationships between modules, the Table 4.3 is compressed into DSM_{cl} shown in Table 4.4.

Table 4.4: The compressed DSM_{cl} representation by modules

		From				
		M1	M2	M3	M4	M5
To	M1	1.889	0	1.889	0	0
	M2	0.975	0	1.771	0	0.983
	M3	0	0	1.816	0.983	0
	M4	0	0	0	0	0
	M5	0	0	0	1.935	1.967

In the DSM_{cl} , we can find that executing M_2 depends on something (i.e. information, output) from M_3 with total dependency strength 1.771. However, the sequence of DSM_{cl} indicates that M_2 is executed before M_3 . Something from M_3 is called feedback as M_3 has not started when doing M_2 . Entry with zero value in the matrix indicates that there is no relationship between modules.

Having the DSM_{cl} , the next step is to re-sequence identified service modules to find sequences with minimum TFB . All possible sequences of modules are generated by enumeration. Figure 4.5 shows the change of TFB along all sequences. The dots in triangle are the three sequences with minimum TFB .

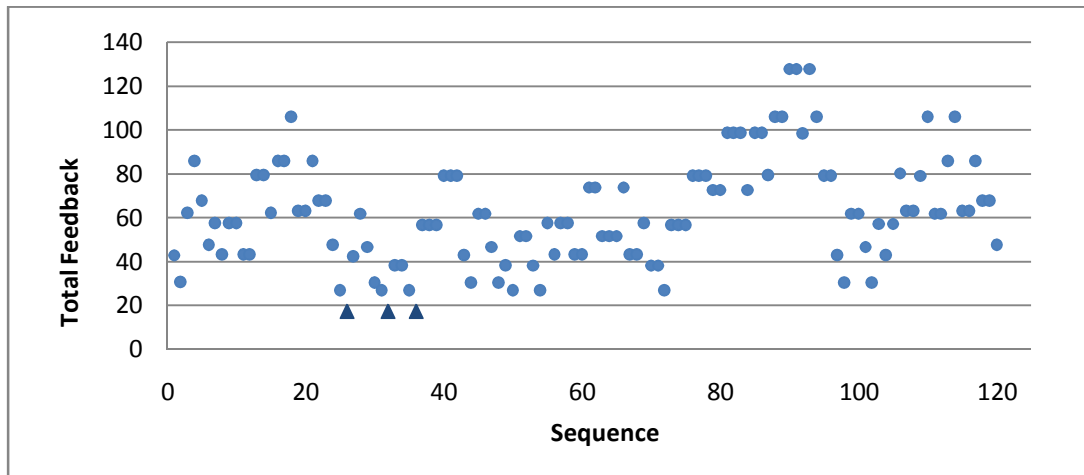

Figure 4.5: The total feedback history for re-sequencing of care modules

The minimum TFB is found at value 17.016 in sequence number 26, 32 and 36.

Results of modules sequence are shown in Table 4.5. The execution sequence of service modules, for example, can be $M_4 \rightarrow M_5 \rightarrow M_3 \rightarrow M_1 \rightarrow M_2$.

Table 4.5: Information of minimum *TFB*

Minimum total feedback at Iteration	The lowest Total Feedback value	Modules sequence				
26	17.016	M_4	M_5	M_3	M_1	M_2
32	17.016	M_4	M_3	M_5	M_1	M_2
36	17.016	M_4	M_3	M_1	M_5	M_2

After considering precedence constraint among healthcare services, the clinical pathways is redesigned and represented by a network diagram in which nodes represent service modules. The relationships between modules are represented by arrows between the nodes. The AND/XOR-split/join constructs are marked. Figure 4.6 is the redesigned clinical pathway of the case.

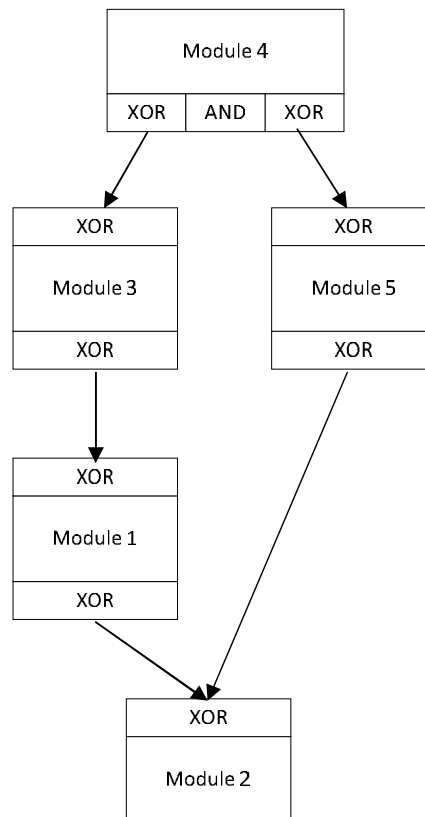

Figure 4.6: The redesigned modular clinical pathway

From the network diagram, we know that a particular patient must go through M_4 (i.e. the registration) before he/she continues his/her journey to receive healthcare services. Then, both M_3 and M_5 are required to conduct. But the sequence of executing which module first is not necessary. M_3 is considered as a precedence of M_1 . So, the start time of M_1 cannot be earlier than the finish time of M_3 . The final module that a patient needs to go through is M_2 . According to the redesigned clinical pathway, all the possible pathways for a patient to flow through are $M_4 \rightarrow M_5 \rightarrow M_3 \rightarrow M_1 \rightarrow M_2$, $M_4 \rightarrow M_3 \rightarrow M_5 \rightarrow M_1 \rightarrow M_2$, and $M_4 \rightarrow M_3 \rightarrow M_1 \rightarrow M_5 \rightarrow M_2$. The redesigned clinical pathway actually covers all three modules sequences with minimum *TFB*. We can see from the redesigned modular clinical pathway, it greatly simplifies the clinical pathway identified by the process mining method through clustering closely interrelated healthcare services into service modules. The healthcare delivery process is further streamlined by adjusting healthcare service modules' sequence with the purpose of minimizing feedback. The case study demonstrates the applicability of the proposed DSM based technique for clinical pathway redesign.

4.5 Summary

In summary, the findings from this chapter suggest that the DSM-based modularization and sequencing algorithm is able to provide a practical support in modular clinical pathway redesign. Healthcare services allocation to care modules is achieved by minimizing *TCC* through GA procedure while the sequencing is accomplished by enumeration to find all sequences with minimum *TFB*. The performance of GA for modularization is analyzed by examining *TCC* with respect to the number of modules, the population size, the crossover rate, as well as the mutation

rate. The compressed *DSM* is constructed to study the relationship between sequence of modules and *TFB*. The clinical pathway is eventually redesigned into a modular clinical pathway based on the re-sequenced process modules and medical constraints. The redesigned pathway provides a foundation to support mass customization of healthcare services through flexible configuration.

CHAPTER 5 HEALTHCARE SERVICE CONFIGURATION BASED ON PROJECT SCHEDULING

To configure healthcare service modules according to individual patient's needs involves enormous complexities and uncertainties. A decision support model is necessary to enable mass customization of healthcare services while leverage resource utilization. In the decision model, the healthcare services configuration problem is formulated as a RCPS. A bi-level GA-based scheduling algorithm is developed and applied to a case study to illustrate the application of healthcare service configuration.

5.1 Significance of Healthcare Service Configuration

A key principle of mass customization is that it is a demand driven, customer centric system (Pine 1993, Tseng et al. 1996). In the context of healthcare, this means individual patients need to be actively involved into the healthcare delivery process by providing key inputs that include their medical needs and preferences. However, there is information asymmetry between patients and physicians, and patients are generally less informed and unable to make critical medical decisions or select medical services on their own. Thus, decision support is necessary to integrate individual patients into the healthcare delivery process. With patient-specific pathway identified and process modules defined, it becomes possible for individual patients to configure their healthcare services by themselves or with the help of healthcare professionals. However, a challenge is that there are a large variety of medical services currently available. Decision support is thus needed in aligning a patient's needs and preferences with the relevant medical services and available resources. To integrate individual patients into the healthcare delivery process, a healthcare service configuration system is developed and shown in Figure 5.1.

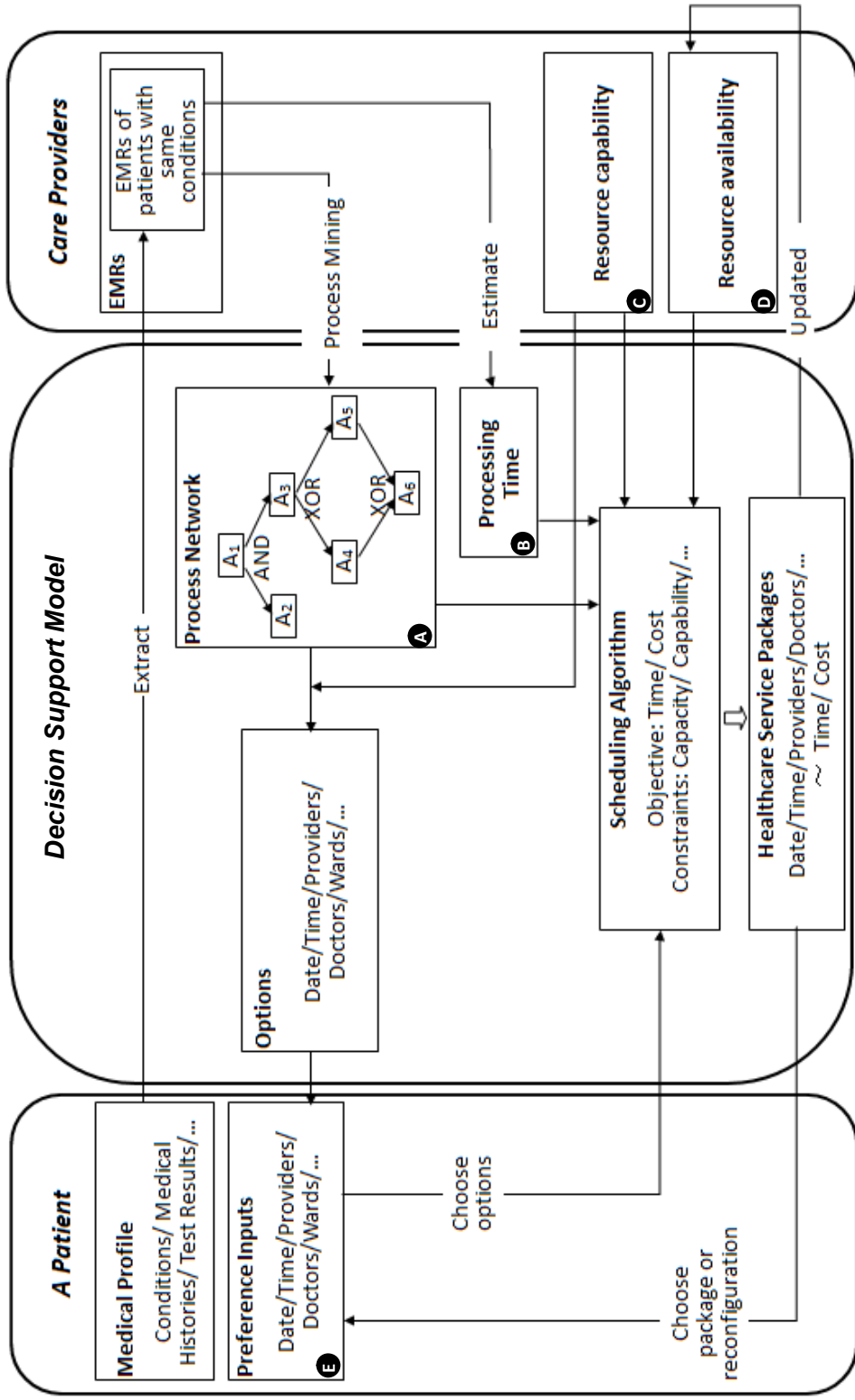

Figure 5.1: A decision framework for mass customization of healthcare services

The framework consists of three modules: a decision support model at the foundation and two interfaces for patients and care providers, respectively. An individual patient's medical profile will be automatically analyzed by the decision support model and alternative feasible healthcare service packages will be suggested accordingly. In more details, the decision support model first takes the patient's medical profile and extracts EMRs of other patients with the same medical conditions. Based on these historical records, process mining technique is used to identify patient-centered process network. The identified process network basically indicates an individual patient's medical needs. We use DSM technique to streamline and redesign the identified process network into modular clinical pathway in order to guide patient care flow. At the same time, processing time for healthcare services or service modules are estimated from extracted EMRs. Then, an individual patient's preferences are taken as inputs and matched with the available resources from the care providers via a scheduling algorithm. The resource capability indicates the required resource(s) for executing a particular care service. The resource availability refers to a resource timetable to denote a resource is available or not in a certain time slot. The output of the scheduling algorithm would be in terms of a healthcare service package. If the patient is not satisfied with the configured healthcare service package, he or she can reconfigure the services by reselecting the options that best match his preferences. There could be a wide range of options for the patient to select from, for example, the date and time, the care provider, the doctor and the level of wards. Once the configuration confirmed, the healthcare service package will update the resource capacity available for the next patient.

5.2 Resource-constrained Project Scheduling

The healthcare service configuration essentially is handling services in healthcare

to create service packages. A healthcare service package, in substance, is a well-coordinated schedule generated for a patient to go through different healthcare services (e.g. tests and consultations). Given a modular healthcare process, the healthcare service configuration can be viewed as selecting and combining components (i.e. care service) and modules (i.e. a cluster of two or more services) in order to find a schedule that matches available resources and satisfies all the constraints and a patient's preferences.

From an operational point of view, a healthcare service package can be treated analogously as a project which is defined as a collection of tasks. Hence, the healthcare service package configuration problem is formulated as a RCPSP. The purpose is to search for an optimum or near optimum solution to assign a start time for each component or module in the pathway to achieve certain objectives (e.g. the minimal overall process time or the minimal cost). The solution should satisfy constraints such as the patient's preference, precedence relationship and resources' requirements.

However, there are some inherent uncertainties in medical diagnosis which display unique characteristics in the healthcare service configuration. Different from project scheduling with a given set of tasks, healthcare services to be scheduled sometimes are not completely known. Decisions on what healthcare services need to be taken depend on examination results and clinical judgments. Instead of scheduling the whole healthcare services for a patient, we generate schedules stage by stage. The set-up of the healthcare package specification procedure is illustrated in Figure 5.2.

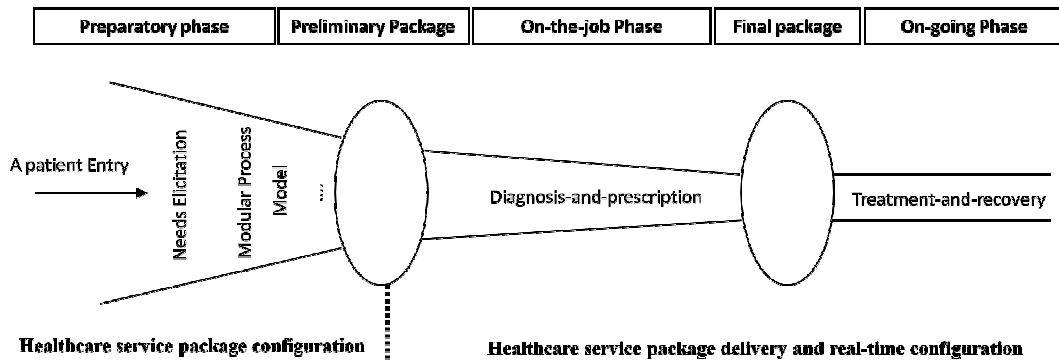

Figure 5.2: Healthcare package specification procedure

For those healthcare services that can be determined before the diagnosis-and-prescription phase, a preliminary package would be generated to give a schedule for a patient to receive those confirmed care services. For those healthcare services decided during diagnosis-and-prescription phase, the scheduling can only be started when the relevant information is available.

The RCPSp has received extensive research since the early days of operations research (Wiest 1967; Pritsker et al. 1969; Davis and Patterson 1975). The objective of classical RCPSp is to determine the feasible start time for each task of the project in order to achieve certain objectives functions. Resource limitations and tasks' sequential relationship make project scheduling essentially a combinatorial problem. Based on the number of projects and resources required by the projects, one can classify such a problem into four broad categories as shown in Figure 5.3.

		Resources	
		Single	Multiple
Project	Single	Single project Single resource	Single project Multiple resources
	Multiple	Multiple projects Single resource	Multiple projects Multiple resources

Figure 5.3: Classification of RCPSp

As we have discussed in previous section, a healthcare service package essentially is a schedule generated for a particular patient to go through different

healthcare services. A healthcare service package can be treated analogously as a single project with a series of healthcare services to be delivered. Health professionals and pharmaceutical equipment are multiple resources used to process healthcare services. In the literature review, main emphasis is on methods solving the multiple resources constrained single project scheduling problem.

The RCPSP is essentially a combinatorial problem because there are many possible options for the starting time of particular activities. There are various solution techniques have been proposed to solve RCPSP (e.g. Davis 1969; Patterson and Huber 1974; Stinson et al. 1978). Generally, they can be categorized into optimization procedures and heuristic procedures.

Optimization procedures can be subdivided into two main streams namely mathematical programming and enumerative method to get the optimum solution. Firstly, the mathematical programming formulates and solves the scheduling problem using integer programming based formulations (Talbot 1982; Patterson et al. 1989). Secondly, enumerative methods use some branch-and-bound techniques to search over a precedence tree procedure for optimum solution. Branch-and-bound methods start with an early work of Johnson (1967). A variety of branch-and-bound algorithms have been developed (Christofides et al. 1987; Patterson et al. 1989; Demeulemeester and Herroelen 1992). Most of them use partial schedules which are associated with the vertices of the enumeration tree. The branching process consists of extending the partial schedule in different ways like the precedence tree, delay alternatives, extension alternatives block extensions.

Most heuristic procedures are priority-rule based scheduling which establishes activity priorities and then uses priority values to select a good combination rather than the best solution (Davis and Patterson 1975). Wiest (1967) is one of the earliest

researchers to propose a heuristics model on scheduling large project with limited resources. His procedure is applied on single project single resource with deterministic activity. Later, the heuristics have been extended to solve multiple resources constrained project scheduling and multiple resources constrained multi-project scheduling by Mohanty and Siddiq (1989). In general, priority-rule based heuristics have the advantage of being intuitive, easy to implement, and fast in terms of computational effort.

A priority rule based scheduling heuristic is made up of two components, a schedule generation scheme and a priority rule. Two different schemes can be distinguished: 1) serial approaches and 2) parallel approaches. A serial approach is to rank all activities of the project in order of priority as a single group, and then scheduled one at a time (serially). In this procedure, the priority of the activity is established only once and you do not change it during the application of the algorithm. A parallel approach, on the contrary, all activities starting in a given time period are ranked as group and resources allocated. At each successive time period a new rank ordering of all eligible activities is made and the process continued. Generally, parallel procedures are proved to be more efficient. A specific priority rule is then employed in order to choose one or more activities from the decision set which then is scheduled. Large numbers of priority rules have been discovered. Browning and Yassine (2010) compared the performance of various priority rules.

Many research studies on the RCPSP recently employed GA, which has been recognized as a powerful and applicable method. GA has been used successfully to solve the standard RCPSP (e.g. Demeulemeester and Herroelen 1992 and 1997; Mingozzi et al. 1998; Klein and Scholl 1999). An extensive review of RCPSP can be found in Brucker et al. (1999). The major disadvantage of the general GA is, however,

that it requires a relatively large amount of computational time to reach the solution space before the solution is finally attained (Espinoza et al. 2005).

5.3 Healthcare Service Configuration

Healthcare service configuration is formulated as a RCPSP to allocate available medical resources over time so that a well-coordinated schedule is generated for a patient to receive different healthcare services.

5.3.1 Healthcare Service Scheduling Formulation

In this study, healthcare service scheduling for an individual patient is formulated as a single project with multiple resources constraints, services precedence relationship, and patient's preferences. The following notations are used in the formulation:

Notations:

m is the set of service modules to be scheduled, $m = 1, 2, \dots, M$.

t is the index for time slot, $t = 1, 2, \dots, T$.

T is the maximum time slot which indicates the time horizon for study.

pt_m is the estimated processing time of the service module m .

Pre_m is the predecessor set of the service module m .

m' is a predecessor of the service module m , $m' \in Pre_m$.

$R_i(m)$ is the service module m required the i th resource.

$R_i(t)$ is the i th resource available at time slot t .

t^* is the patient's preferred starting time slot.

From the redesigned modular clinical pathway, we are able to know all or at least parts of healthcare services that a particular patient needs to go through. Before the diagnosis-and-prescription phase, a set of must-go healthcare services are already known from the modular clinical pathway. A patient is going to receive M healthcare

service modules labeled by $m=1,2,\dots,M$. The processing time of the service module m is denoted as pt_m . The precedence relations are given by the Pre_m which indicates a set of predecessors of the service module m . Each service module requires certain amounts of resources to be performed. Resources are considered to be renewable and constant available over time. The service module m requires $R_i(m)$ units of the i th resource in each time slot. It is assumed that once a service starts, its progress is not interrupted. Also the number of different resources required and the amount required of each resource by an activity are assumed to be constant. The amount of the i th resource available at time slot t is constant at $R_i(t)$. The healthcare service package configuration problem is formulated as below:

<p>Given: $m, Pre_m, pt_m, T, R_i(m), R_i(t), t^*$</p> $\text{Minimize } (t \cdot x_{Mt} + pt_M - t \cdot x_{1t}) + t \cdot x_{1t} - t^* \quad (5-1)$ <p>where</p> $x_{mt} = \begin{cases} 1, & \text{if activity } m \text{ starts at time period } t, m=1,2,\dots,M. \\ 0, & \text{otherwise.} \end{cases}$ <p>subject to</p> $t \cdot x_{mt} \geq \max_{m' \in Pre_m} \{t \cdot x_{m't} + pt_{m'}\} \quad (5-2)$ $t = \max_{m' \in Pre_m} \{t \cdot x_{m't} + pt_{m'}\} \quad (5-3)$ $\sum_{m=1}^M x_{mt} \leq 1, t=1,2,\dots,T. \quad (5-4)$ $\sum_{t'=t}^{t+pt_m-1} x_{mt'} = pt_m, \text{ when } x_{mt} = 1. \quad (5-5)$ $x_{mt'} \cdot R_i(m) \leq R_i(t), t'=t, t+1, \dots, t+pt_m-1. \quad (5-6)$
--

The objective is to find a schedule which makes the makespan (i.e. total processing time) for an individual patient as short as possible and at the same time keeps the starting time as close as possible to the preferred time slot t^* . The objective is formulated as (5-1) to minimize the summation of makespan of healthcare service package and the difference between the starting time and the patient's preferred starting time slot. The makespan refers to the difference between the starting time of the last service module (i.e. $t \cdot x_{Mt} + pt_M$) and the starting time of the first service module (i.e. $t \cdot x_{1t}$). In the objective function, decision variables are x_{mt} which indicate activities starting time period. If the activity m starts at time period t , x_{mt} is equal to 1, otherwise 0. Activities precedence relationships are maintained by Constraint (5-2). An activity (i.e. a service) can only start when all activities in its precedence set have finished. Constraint (5-3) makes sure there is no redundant activity in an acyclic process network. Constraint (5-4) and (5-5) insure non-preemptive activity. A patient can only receive a service at a time. When the patient is receiving a service, no other service can interrupt and conduct on this patient. Resource restriction is imposed by Constraint (5-6). In each time period, total resources consumption cannot exceed the amount of available resource. In summary, these constraints insure that a service is conducted on a patient only if sufficient resources are available and its precedent service has been finished.

5.3.2 A Bi-level Scheduling Algorithm

To solve the healthcare service scheduling problem, there are two main challenges. One challenge of the scheduling is that the sequence of activities in the process network is not deterministic. The other challenge is how to schedule resources to conduct the sequence of activities. These two challenges are hierarchical

decision-making problems where the search spaces are different. The feasible sequences of activities affect resources allocated to execute the process. At the same time, the resources arrangement has impact on makespan for an individual patient. Therefore, a bi-level GA scheduling algorithm is developed for solving RCPSP in a same framework. An overall framework of the proposed algorithm is given in Figure 5.4.

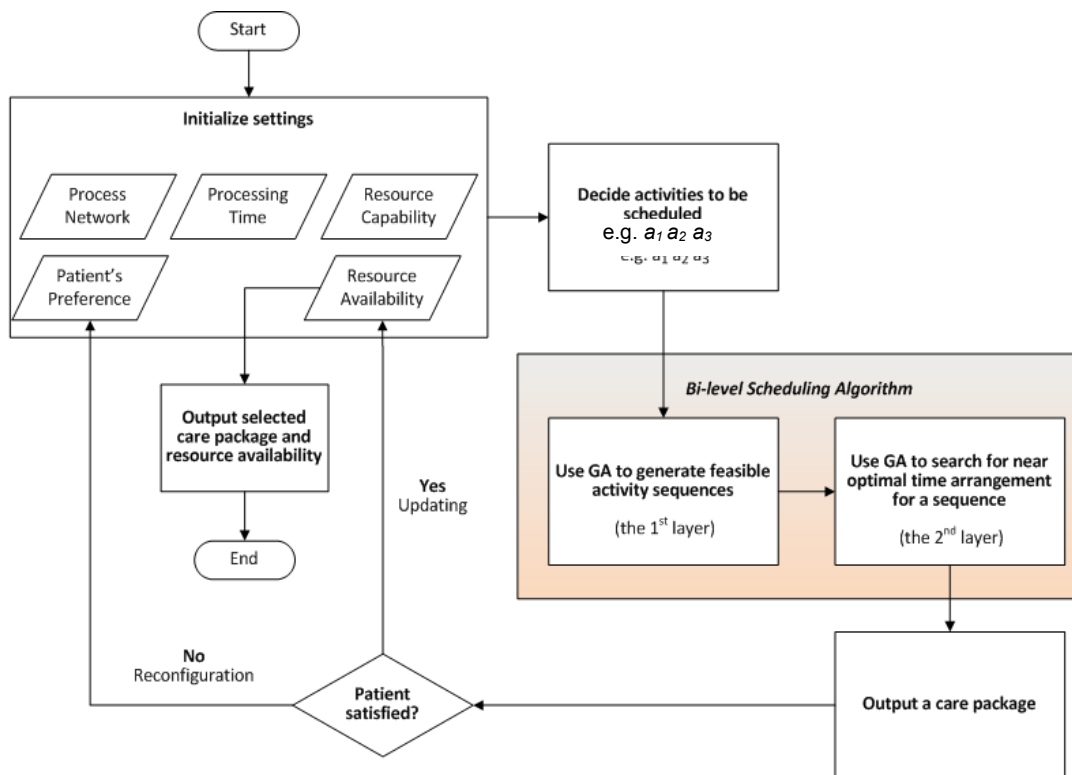

Figure 5.4: An overall framework of a bi-level GA scheduling algorithm

As we have discussed in Section 5.2, healthcare service package may not be able to generate in a whole at one time. Before we obtain more detailed medical information, we may only schedule activities up to certain point. With given information on process network, we first decide what activities need to be executed on the particular patient. Then, bi-level scheduling algorithm is applied. The first layer GA is used to perform an initial search in order to exam the feasibility of activity

sequences. Only the feasible activity sequence (i.e. the sequence with high fitness value) obtained from the first layer will be an input to the second layer of the algorithm. The second layer GA is employed to search for a near optimum time arrangement to allocate resources according to resource capability, resource availability and the patient's preferences. The purpose is to generate a schedule containing a serial of healthcare services within a minimum time horizon. Therefore, a healthcare service package is generated for patient to make a choice. The patient can reconfigure until the generated package can best match his preferences. Once a package confirmed, the resource availability information will be updated and the algorithm is ready for the next patient to conduct configuration. Figure 5.5 details the operation of the proposed bi-level scheduling algorithm.

The purpose of the first layer GA is to generate feasible activity sequences. The project specific schedule data and the parameters for global search are prepared at the very beginning of the operation. The random number generator produces an initial population composed of activity sequence individuals. Each individual is encoded as a vector which indicates an activity sequence for the problem. Each gene stands for an activity number which assigns an integer number between 0 and as many as service modules (or healthcare services) in the clinical pathway.

In GA, a fitness value of an individual in a population is needed to conduct the optimization procedure. However, it is not easy to calculate the fitness value directly in our study. Therefore, we substitute a cost function for a fitness function. In contrast to calculate how good an individual is, the cost function indicates how bad an individual is. In other words, an individual with lower cost is better. The Activity Sequence Cost (ASC) is initialized at infinite large which means an individual is totally not a feasible sequence. A set of tests are designed to exam the sequence

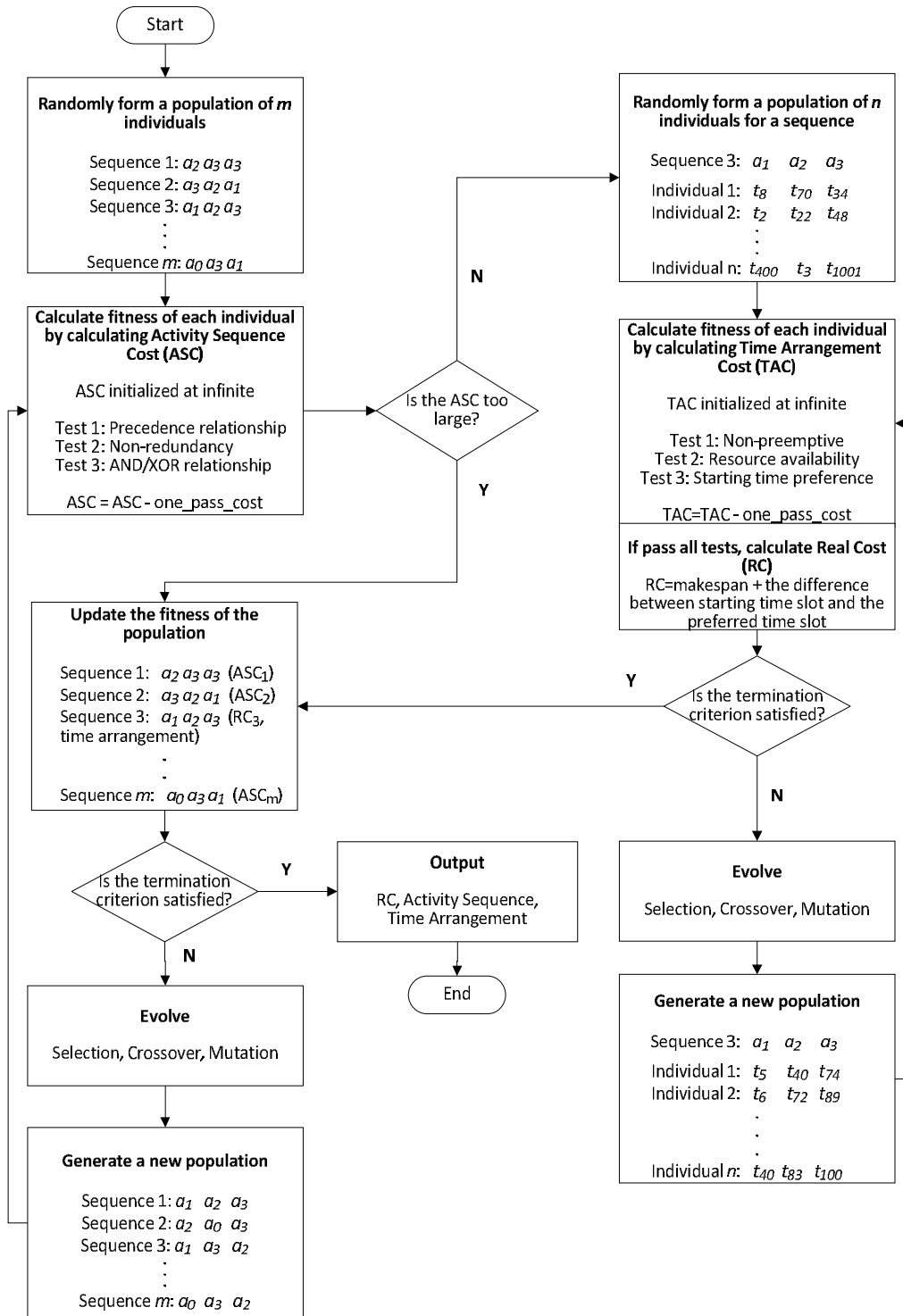

Figure 5.5: A bi-level GA scheduling algorithm

feasibility, namely precedence relationship test, non-redundancy test and AND/XOR relationship test. If an individual pass one of the tests ASC will be reduced by certain amount (i.e. one_pass_cost). For an individual, the more tests it can pass the lower

cost it is. Only the individuals with low ASC values are feasible sequences. Their ASC values will be updated by Real Cost (RC) after going through the second layer GA. Other individuals' ASC values keep as the same. Thus, we will obtain the partially updated population. Then, an evolution process is achieved if the termination criterion is not satisfied, that is to say, the search does not converge. Three basic operators are applied in the evolution process. They are roulette wheel selection, single-point crossover, and uniform mutation. Elaborations of these operators have been given in Appendix E. The iterations will go on until the termination criterion is satisfied. The final results contain activity sequence, time arrangement of resources and RC.

The time arrangement of resources corresponding to a feasible activity sequence is gotten from the second layer GA. For each of the feasible activity sequence identified in the first layer, the randomly generated initial population in the second layer consists of activity starting time. The encoding of each individual indicates a sequence of starting time slot allocating to an activity. Each gene stands for an activity's starting time slot by assigning an integer number between time 0 and the time horizon T . Following the same consideration, we use a Time Arrangement Cost (TAC) function to decide the direction of learning. Considering constrains on resources availability, activities' non-preemptive relation, and the patient's preferred starting time, we subtract certain value of cost from the initial TAC if one of the tests is passed. For an individual, if it passes all above mentioned three tests, RC is calculated to show the sum of makespan for a particular activity sequence and the difference between the stating time slot and the preferred time slot. The iterations of evolution will keep on until the search converges.

5.4 Healthcare Service Configuration

With the redesigned modular clinical pathway in Subsection 4.4.3, how the decision support model proposed in Section 5.1 enables healthcare service configuration is illustrated in the following subsections. The values of the GA parameters are decided by applying the DOE technique. A 2^4 factorial experiment is conducted and shown in Appendix H.

The redesigned pathway (shown in Figure 4.6) serves as a fundamental input to the decision support model (see A in Figure 5.1) in the case study. The redesigned pathway basically tells us the service modules to be scheduled (m), the predecessor set (Pre_m) and process structure between service modules and services in each module. The processing time is assumed to follow a lognormal distribution. For each healthcare service, the processing time is estimated from the event log extracted from outpatients' EMRs from TTSH (see B in Figure 5.1). The processing time for a service module (pt_m) is estimated by aggregating all individual care services in the same cluster. For example, the processing time of M_1 is estimated to follow a lognormal distribution with μ and δ equal to 2.7762 and 0.7980 respectively.

Figure 5.6 draws the cumulative distribution function of M_1 processing time.

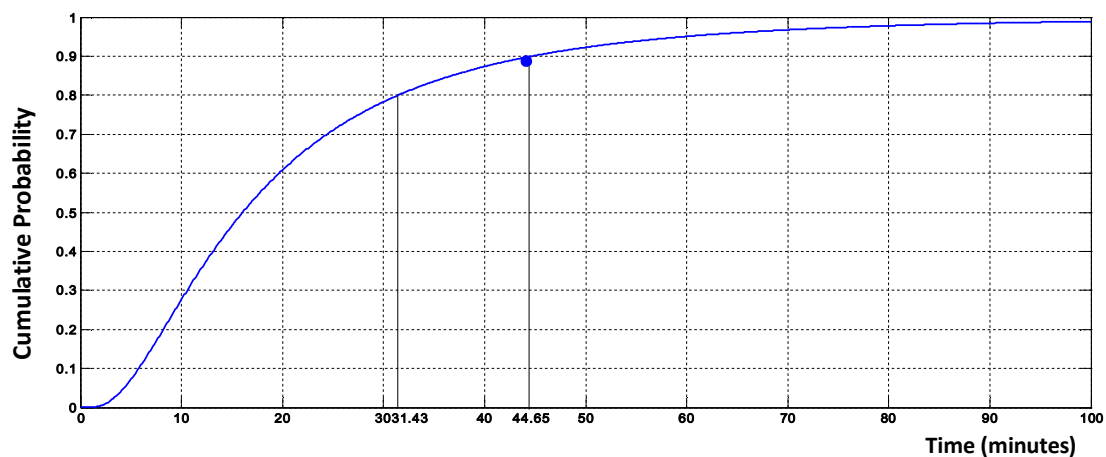

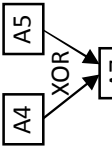

Figure 5.6: CDF of M_1 processing time (LogN(2.7762, 0.7980))

The point 0.9 with corresponding time value 44.65 minutes implies that 90% probability will be found that patients can finish their healthcare service M_1 within 45 minutes. In other words, the service level is 90%.

As the healthcare service configuration problem is formulated as a discrete time scheduling problem, we considered two scenarios of the processing time, namely 80% and 90% service level. Every 5 minutes interval is represented by a time slot. The above mentioned information is summarized into Table 5.1.

The resource capability (see C in Figure 5.1) indicates which resource(s) has the capability of executing a particular care service and how many unit(s) is going to be consumed for execution. The resource availability ($R_i(t)$), refers to a resource timetable to denote if a resource is available or not in a certain time slot (see D in Figure 5.1). In this specialist outpatient clinic case study, we limit our consideration mainly on resources of health professionals. It is assumed that medical equipments (e.g. X-ray machine, ECG) and technicians are available throughout the study period. The detailed staff managing information of resource availability is obtained from TTSH. A normal working day is divided into 2 work shifts, namely the morning and afternoon shift. The morning shift is 8:00-13:00 and the afternoon shift is 14:00-17:00. The doctors at clinics are present for consultation and treatment only periodically according to their shift schedule. We notice that each doctor is associated with a nurse for assistance. A summary of resource availability and capability in the morning of May 4, 2009 in Clinic 3B and Clinic 2A is in Table 5.2 for the ease of applying the proposed bi-level scheduling algorithm.

Table 5.1: Predecessor set, process structure and estimated processing time of redesigned clinical pathway

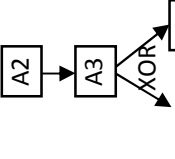
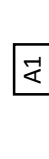
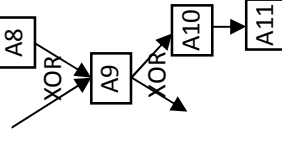
Module No.	Module Predecessor set	Module process structure	Service No. in the module	Services in the module	Service processing Time (minutes)	Relationship in the module	Module processing time		
							Assume Lognormal Distribution	90% Service Level	80% Service Level
M1	[M3]	-	A4 A5 A7	Fundus Fluorescein Angiography Humphrey Visual Field Test 2 nd Eye Consultant	LogN(1.8667, 0.3568) LogN(3.5031, 0.1141) LogN(1.7832, 0.7760)		LogN(2.7762, 0.7980)	44.65 mins (9 time slots)	31.43 mins (6 time slots)
M2	[M1, M5]	XOR-join	A12	Bill & Payment	LogN(1.6019, 0.7197)		LogN(1.6019, 0.7197)	12.48 mins (3 time slots)	9.09 mins (2 time slots)
M3	[M4]	-	A2 A3 A6	Eye Sight Test 1 st Eye Consultant Laser Procedure	LogN(1.7271, 2.221) LogN(0.5644, 0.6056) LogN(2.7081, 0)		LogN(2.8465, 0.4563)	30.42 mins (6 time slots)	25.29 mins (5 time slots)
M4	∅	-	A1	Registration	LogN(1.3095, 0.3968)		LogN(1.3095, 0.3968)	6.16 mins (1 time slot)	5.17 mins (1 time slot)
M5	[M4]	-	A8 A9 A10 A11	ECG 1 st Cardiology Consultation X-ray 2 nd Cardiology Consultation	LogN(0.8291, 0.9078) LogN(1.9059, 0.5390) 5 5		LogN(2.0863, 0.6013)	14.1 mins (3 time slots)	13.36 mins (3 time slots)

For the purpose of clear demonstration and comparison of the healthcare service configuration, we will focus on a particular doctor, the Dr Lim, in Clinic 3B (Cardiology Clinic) who has appointments with 14 patients in the morning shift on May 4, 2009. This is because a general high peak of patients' visits is shown on Monday. The patients' visiting schedules are extremely important for coordinate healthcare service delivery to achieve high service expectations. Moreover, according to the patients' EMRs, there are 5 of them also suffered from an eye problem. The 5 patients made appointments with different ophthalmologists in Clinic 2A (Eye Clinic) on another day. Comparison is able to be conducted between their actual procedures and our developed methods.

The detailed information of the 14 patients' EMRs is summarized in Table 5.3. The table also shows individual patient's makespan which is the length of time between patient's registration and finishing the last healthcare service module. In other words, the makespan describes the time of receiving healthcare services and waiting to be served.

Table 5.3: Patient current appointment and makespan

Patient No.	Appointment in Clinic				Actual Makespan in Clinic			
	Clinic	Date	Time	Doctor	Registration Time	Finishing Time	Makespan	
							Minutes	Time slots
1	3B	2009-5-4	9:35	Dr Lim	9:55	10:25	0:30	6
	2A	2009-5-6	11:05	Dr Foo	10:04	12:29	02:25	29
2	3B	2009-5-4	11:30	Dr Lim	11:50	12:31	0:41	8
3	3B	2009-5-4	11:50	Dr Lim	11:26	12:10	0:44	9
4	3B	2009-5-4	10:20	Dr Lim	10:10	11:30	1:20	16
5	3B	2009-5-4	11:30	Dr Lim	11:25	12:04	0:39	8
6	3B	2009-5-4	11:20	Dr Lim	11:21	12:02	0:41	8
	2A	2009-5-6	09:00	Dr Foo	07:56	08:45	00:49	10
7	3B	2009-5-4	10:40	Dr Lim	09:25	11:35	2:10	26
8	3B	2009-5-4	10:05	Dr Lim	09:45	10:45	1:00	12
	2A	2009-5-6	16:10	Dr Foo	15:21	16:50	01:29	18
9	3B	2009-5-4	10:00	Dr Lim	09:40	10:25	0:45	9
	2A	2009-5-7	08:35	Dr Ng	08:23	09:39	01:16	15
10	3B	2009-5-4	11:40	Dr Lim	11:10	11:45	0:35	7
11	3B	2009-5-4	10:15	Dr Lim	09:46	10:36	0:50	10
12	3B	2009-5-4	10:35	Dr Lim	10:22	11:08	0:46	9
13	3B	2009-5-4	10:30	Dr Lim	10:04	10:48	0:44	9
	2A	2009-5-6	09:20	Dr Ng	08:59	10:32	01:33	19
14	3B	2009-5-4	09:40	Dr Lim	09:23	10:19	0:56	11

Now, an individual patient can configure the healthcare services by selecting the options that best match his preferences (see E in Figure 5.1). If we consider the healthcare service configuration from a system level, there could be a wide range of options such as the preferred care providers (e.g. TTSH, SGH, and NUH), the preferred doctors (e.g. senior doctor or registry doctor), the preferred visiting date and time, and the preferred wards (e.g. A1, B4 or C). However, the case study we

conducted in this research focused on the patients who visit both Clinic 2A and Clinic 3B in TTSH. The options considered limit to the preferred doctor, date and time. Once a patient selected the preferred doctor option, the resources required to execute the healthcare service “Consultant” have been determined. When a patient chose a preferred date and time, the corresponding time slot (t^*) in the scheduling algorithm is defined. The preferred time slot indicates that the suggested healthcare service package should not be far away from the particular time slot.

With the given information, a healthcare service package can be configured by using the bi-level GA-based scheduling algorithm (for Matlab codes see Appendix G). To demonstrate how the healthcare configuration decision support model works, we assume all information is the same as the as-is situation. A patient was suffered from both cardiovascular condition and eye problem. He made his choices on options in the decision support model. He would like to see Dr Lim a Cardiologist at 9:35am for his cardiovascular condition. At the same time, he would like to consult Dr Foo for his eye problem in the same hospital visit. So he ticked the corresponding options. He had no specific requirement on technicians for his medical tests or examinations. The selected options are shown in Table 5.4.

Table 5.4: Selected options

Resource Name	Resource Type	Options	Preferred Time	Options
Dr Lim	Cardiologist	<input checked="" type="checkbox"/>	8:00	<input type="checkbox"/>
Fizah	Radiology Technician	<input type="checkbox"/>	8:05	<input type="checkbox"/>
Dr Foo	Oculist	<input checked="" type="checkbox"/>	8:10	<input type="checkbox"/>
Dr Ng	Senior Oculist	<input type="checkbox"/>	...	<input type="checkbox"/>
PSA: Fara	Eye Testing Technician	<input type="checkbox"/>	9:35	<input checked="" type="checkbox"/>
PSA: Kavitha	Eye Testing Technician	<input type="checkbox"/>	...	<input type="checkbox"/>
Chin Choi Lan	Lasik OT	<input type="checkbox"/>		<input type="checkbox"/>
Ruey	Ophthalmic Technician	<input type="checkbox"/>	12:30	<input type="checkbox"/>

The algorithm is able to automatically generate an appointment schedule specific

for him. The generated healthcare service package and resources utilization status are exhibited in Figure 5.7.

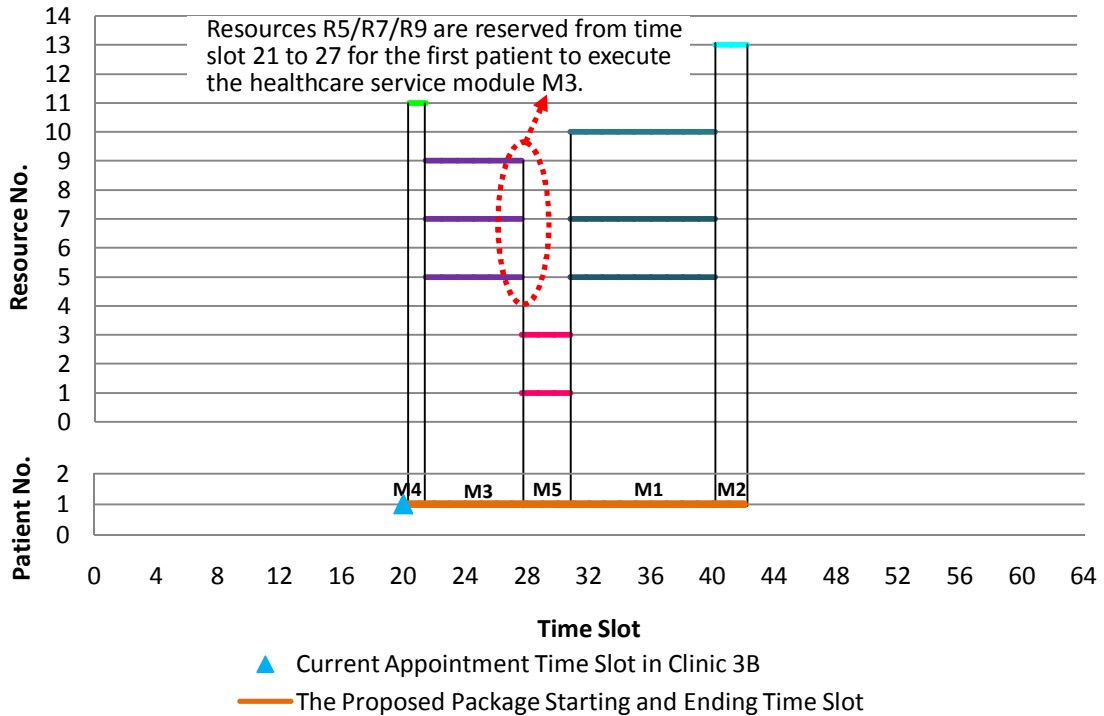

Figure 5.7: The schedule and resources utilization status

As indicated in the graph, the blue triangle shows the patient's preferred time slot (the same as the current appointment time) and the orange line shows the suggested healthcare service package. The package basically tells the sequence of going through different healthcare service modules by taking the patient's preferences (i.e. options) and resource availability and capability into consideration. In this case study, the first patient select 9:35 am (i.e. $t^* = 21$) as his preferred time slot. The configured healthcare package indicates that the patient need go through healthcare service module in the sequence of $M_4 \rightarrow M_3 \rightarrow M_5 \rightarrow M_1 \rightarrow M_2$. If the patient confirmed his package, corresponding resources will be reserved during the execution time slots as shown by lines in the upper part of the figure. For instance, resource R_1 and R_2 namely Dr Lim/Nurse: Naga and Radiology Technician: Fizah will be reserved to

conduct service module M_5 . And the resources availability will be updated for the next patient to do configuration. If the patient is not satisfied with the suggested healthcare service package, he can reconfigure by reselecting different options until the suggested package matches his preferences the best.

The above demonstration exhibits how an individual patient can configure his/her healthcare service package by providing key inputs including medical needs and preferences. Schedules for a sequence of healthcare services or modules are suggested for the patient to select from. Next, we are going to conduct what-if analysis to compare the appointment time and makespan of the as-is and to-be cases.

The current appointment of an individual patient is obtained from EMRs and illustrated in Figure 5.8 using a blue triangle. We can see that appointments basically are scheduled on an interval of 5 minutes (i.e. one time slot). And appointments are centralized during the period of time slot 21 to time slot 46. The allocation of appointments mainly considers the availability of doctor.

In the proposed healthcare service configuration, the objective is to minimize the makespan of an individual patient and simultaneously to schedule the package as close as to the patient's preferred time slot. When conducting scheduling, the resource availability, the resource capability and healthcare service modules' relationship are considered as constraints. The healthcare service package scheduled for each patient is shown as a solid green color line for 80% service level and a dotted red line for 90% service level in the following Figure 5.8. The lines indicate the starting time of executing the first healthcare service module of the patient until finishing the last healthcare service module.

From the graph, we notice that all patients have their healthcare service package to be scheduled for both cardiovascular condition and eye problem in one hospital

visit. There are 5 patients whose packages start right at their preferred time slot (assume that their current appointment time slot is the patient's preferred time slot). The maximum difference between the preferred time slot and the starting time of healthcare service package appears on the patient number 13 with service level 90%. The patient is scheduled 30 time slots earlier than his/her preferred time. The reason may lie on the fact that some resources have been reserved by patients who configured earlier. We conclude that higher service level results in a larger deviation of healthcare service package starting time from the preferred time slot. It is due to longer resources reservation period.

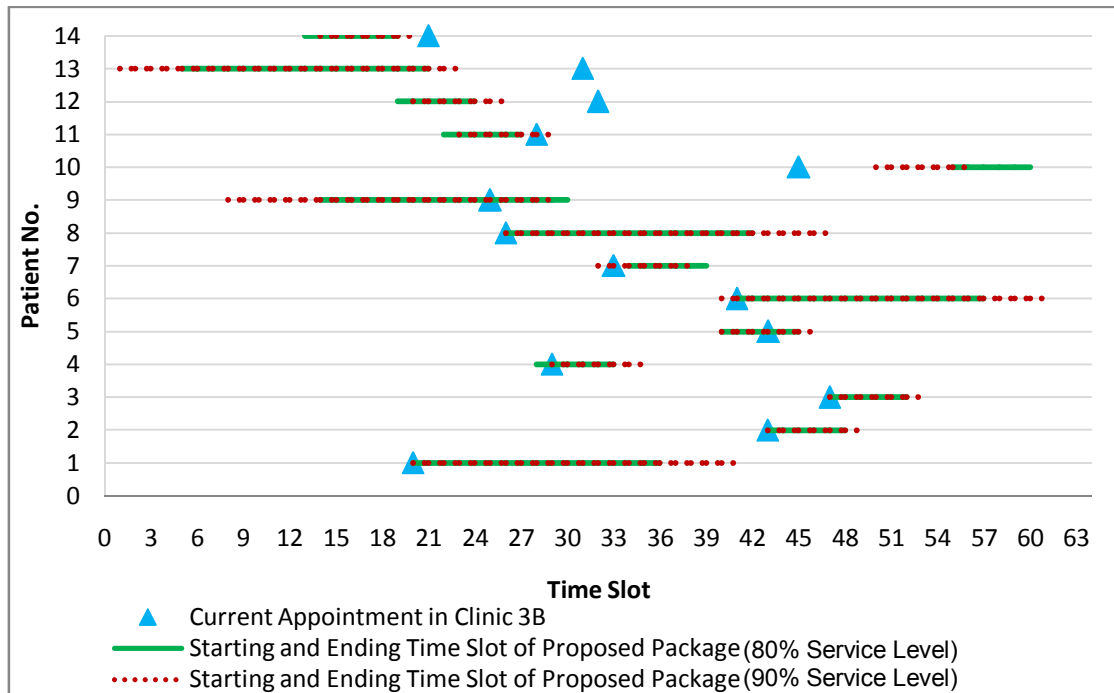

Figure 5.8: The scheduled healthcare service package

Even though some healthcare service packages cannot be all scheduled at the patient's preferred time slot, the makespan for an individual patient reduces significantly. As an individual patient with both cardiovascular condition and eye problem need visit Clinic 2A and Clinic 3B with different appointments, the

makespan, from the patient’s point of view, is the sum of two visits. The current makespan of a patient in both clinics is compared against the makespan of the proposed method in Figure 5.9.

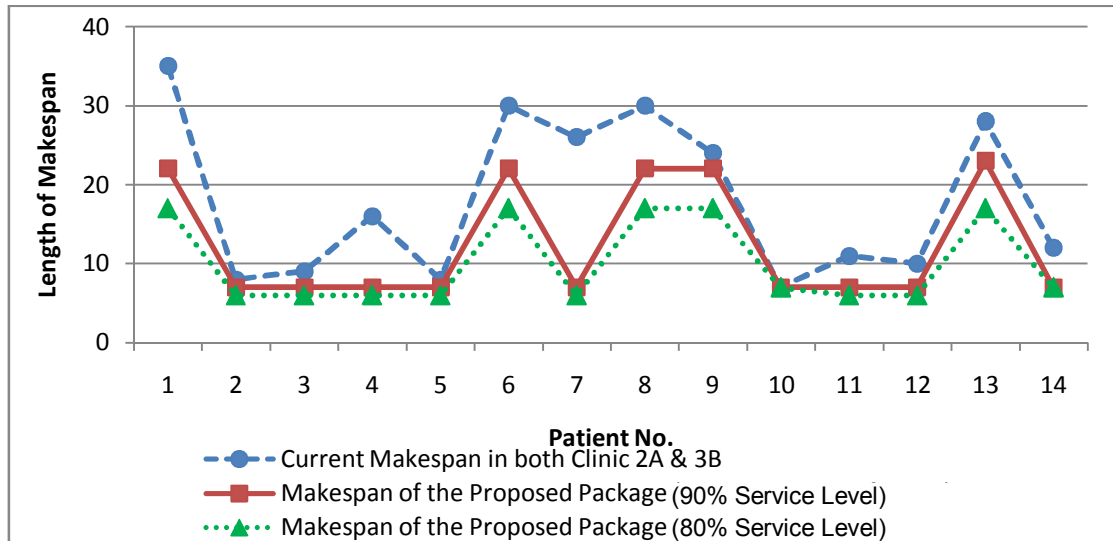

Figure 5.9: The current makespan vs. makespan of the proposed method

The current makespan of 14 patients are shown as a blue dash line with circle markers. The first patient is found to have the longest makespan 35 time slots (i.e. 175 minutes). The green dotted line with triangle markers and the red solid line with square markers illustrate the makespan of an individual patient through healthcare service configuration with 80% and 90% service level, respectively. Over 14 scheduled patients, 13 patients’ makespans are shorten and 1 patient’s makespan (i.e. the patient no. 10) breaks even. The makespan of patient no. 7 reduces the greatest (a decrease of 95-100 minutes). On average the reduction of an individual patient’s makespan is 39.75% and 28.66% for service level 80% and 90%, respectively. A major cause of the reductions is that the configuration facilitates better coordination on medical resources across clinics and departments. Consequently, the waiting time between healthcare services is reduced. In addition to makespan reduction, patients

(i.e. patient no. 1/6/8/9/13) with both cardiovascular condition and eye problem are scheduled in a single clinical visit rather than two visits on different days.

However, there are some variations on patients' arriving time and healthcare service processing time when delivering healthcare services in practice. In order to ensure the proposed healthcare service packages to be delivered under such situation, the resources are reserved longer than the actual required healthcare service makespan. This way leads to a decrease in the resource utilization rate. The resource utilization rate is a ratio of actual healthcare service processing time over the resource reservation time for an individual patient. The trend of resource utilization rate is described in the Figure 5.10 with respect to the change of resource reservation time.

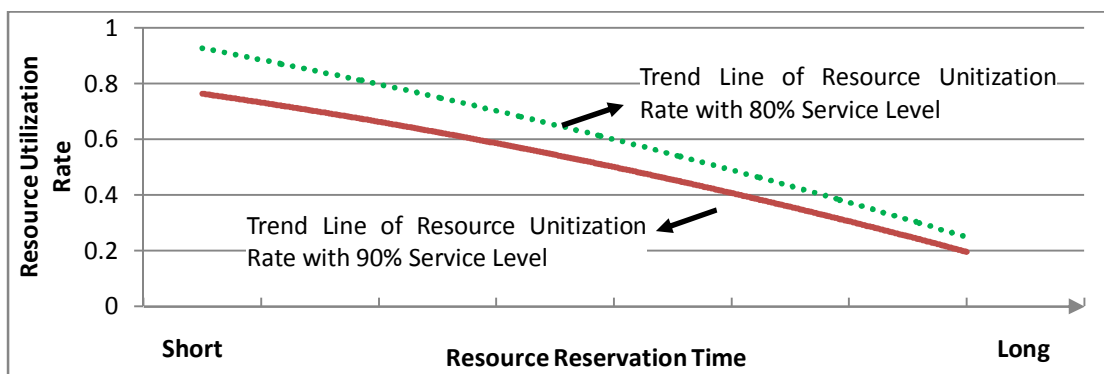

Figure 5.10: Resource utilization rate vs. healthcare package resource reservation time

We can find from the graph that the longer the healthcare service package reserving medical resources the lower the resource utilization rate. Resource utilization rate of healthcare package with 90% service level is always lower than that with 80% service level. The comparison indicates that careful decisions on the patient service level need to be made when implementing healthcare service configuration.

5.5 Summary

A decision support model is developed in this chapter to integrate individual

patients into the healthcare service configuration process. The healthcare service configuration is formulated as a RCPSP, for which a bi-level GA-based scheduling algorithm is developed and demonstrated in a case study by examine different schedules and the associated resource utilization. What-if analysis is justified by comparing the makespan of the as-is and to-be cases. Change of resource utilization rate over the resource reservation time verifies the consistency of the trend of utilization rate and different satisfaction levels. Healthcare service configuration essentially enables the healthcare services to be customized and delivered with high efficiency.

CHAPTER 6 CONCLUSION AND FUTURE WORK

This chapter first summarizes research has been done and highlights the original contributions. Limitations are discussed and prospective works are stated in the following sections.

6.1 Research Summary

There are an increasing number of patients, especially those with multiple medical conditions, who demand customized healthcare services that are tailored to their individual-specific needs. However, the delivery of healthcare services in most current healthcare systems are centralized at care providers and patients need go through different functional departments to receive care. The mainstream healthcare service delivery is similar to a product going through an assembly line in a manufacturing system that operates based on the principle of mass production. The supply-driven healthcare delivery system with increasingly specialized disciplines is becoming ineffective to fulfill the increasingly diversified patients' needs for healthcare services. Inspired by the success of mass customization in delivering customized goods according to individual customers' needs with high efficiency and low cost in manufacturing industry, this research makes an original contribution by investigating the theoretical feasibility and practical applicability of adopting mass customization for healthcare service delivery.

This research conducts a survey of literature that is most relevant to the proposed research, which includes the basic concept of mass customization and recent development in healthcare delivery system research. It is found that although healthcare differs from manufacturing in many significant ways, the basic value proposition of mass customization in terms of *being demand-driven*, *modularity*, and

value co-creation via configuration is generic and can be generally transferred into service industry in general and healthcare services in particular. Recent development on healthcare service delivery researches including *evidence-based medicine*, *personalized medicine*, *consumer-driven healthcare*, *consumer healthcare informatics*, and *integrated healthcare delivery*, are all pointing in the direction of mass customization of healthcare services from different angles.

This research makes contribution by developing a data-driven process redesign methodology to enable mass customization of healthcare services. The fundamental difference between healthcare and manufacturing lies in the former being a type of service and it mainly deals with processes instead of products. However, the basic concepts and principles are generic for both product and service systems and hence can be transferred to healthcare service delivery. Corresponding to these basic concepts and principles of mass customization, this research focuses on addressing three main research issues, namely *patient-centered pathway identification*, *healthcare process modularization*, and *healthcare service configuration*, which are the key enablers for mass customization of healthcare service. The results and findings on each of these research issues are summarized in the following.

1) *Patient-centered pathway identification*

Mass customization is essentially a pull-based system that is driven by the demand of individual customer (patients in the context of healthcare). It is a prerequisite to start healthcare services delivery process with individual patient's specific needs. In the transition towards mass customization of healthcare services, the first thing to do is to understand patient's needs and match them with corresponding healthcare services, which can be summarized in a clinical pathway. However, the complexity involved in both patients' diversified medical needs and the large number

of medical service offerings adds to the difficulty of establishing appropriate relationship between them.

The method based on process mining is able to sift through a large number of patients' activities in event logs, which record detailed healthcare services provision to individual patients, and match them with patients' medical profiles. Through identifying the activities' dependency relationship by aggregating a group of patients, the correct ordering of activities and process constructs are discovered and reflected in a process model, which represents the clinical pathway for a patient with a particular medical profile. The identified clinical pathway describes the main observed behavior in the event log and provides a clear insight into what services are consumed. The case study demonstrates the capability of process mining in extracting a well-structured process model, which can serve as a basis to devise customized pathways according to patient's specific conditions.

2) Healthcare process modularization

Traditionally, customization has been associated with high variety, which often leads to high complexity and low efficiency. A key dimension that mass customization differs from traditional customization is its ability to offer high variety of products/services to customers while controlling internal complexity and cost in operations. This is often achieved through modularity, which entails partition of products or services into standard modules that can be produced or delivered with high efficiency individually and can be combined flexibly to form a large number of variants to cater to diversified needs. In the context of healthcare delivery system, medical services are often closely interrelated with each other through information exchange and resources sharing. Unlike modularity in manufacturing, mass customization of healthcare services requires modularity of processes, which

decomposes healthcare processes into sub-processes (i.e. service modules) that are composed of a group of activities (i.e. components) defined based on a specific function. The dependence among process modules is relatively low and standard modules can interact with each other through interfaces either in parallel or in sequence relationship. Modular process design is a general method to decrease system complexity, increase efficiency and achieve both flexibility and variety due to the features of “encapsulation” and “plug-and-play”. So, modularization is a key factor to achieve mass customization of healthcare services.

This research develops a process modularization method using activity-based DSM. The matrix records pathway networks based on services’ information flow and dependencies relationship. By identifying closely interacted healthcare services across a group of different patients, the clinical pathway is clustered into service modules. The DSM further provides the ability to adjust service modules’ sequences in order to minimize feedback among different modules so as to cut the cost and support redesign. The case study shows that implementing GA-based modularization and sequencing algorithm is able to cluster strongly interacted healthcare services into service modules and re-sequence service modules in order to minimize the feedback information. The clinical pathway is eventually redesigned into a modular clinical pathway that provides a foundation to support mass customization of healthcare services through flexible configuration.

3) *Healthcare service configuration*

Mass customization of healthcare services aims to fulfill individual patients’ needs. With patient-specific pathway identified and process modules defined, it becomes possible for individual patients to configure their healthcare services themselves or with the help of health professionals. The configuration through the

proposed decision support model facilitates patients actively involved in the healthcare package design by providing their preference. So that the decision support model is able to suggest a solution that matches providers' resource capability and availability with patients' specific preference. An individual patient is able to select a healthcare service package that best fit his/her needs.

This research formulates healthcare service configuration as a RCPSP. The objective is to generate a healthcare service package that best fits an individual patient's needs with minimum makespan. A bi-level GA-based algorithm has been developed to solve the configuration problem. The feasibility of adopting RCPSP for healthcare service configuration was demonstrated by the case study. From comparison analysis, we found the proposed healthcare service package is able to significantly reduce the makespan of patients through coordinating healthcare services from various clinics or departments. Configuration essentially enables the healthcare services to be customized and delivered with high efficiency.

6.2 Limitations and Future Work

Mass customization of healthcare services is still a novel concept both in academic research and industry applications. Up to date, this research has been focused on defining and formulating a research problem in a proper context, establishing a unified conceptual framework, and developing a set of methodologies. The applicability and feasibility of proposed methodologies in this thesis are demonstrated by a case study on processes of healthcare delivery in a hospital setting. In general, mass customization provides a promising concept and a framework that can potentially transform the design of healthcare service delivery systems. However, some limitations of the methodologies proposed need further improvement and implementation.

An appropriate and accurate process model representation is of critical importance in the quality of mapping and modular process design. Process mining is proposed to establish the mapping through statistical correlation analysis. To integrate generic medical knowledge into process network discovery deserves future studies. The algorithm applied to analyze and abstract information from event log is Heuristics Miner, which is weak of handling duplicate activities. Future improvement on the algorithm is needed. The application of the proposed method is limited in a small scale case study. Future studies on broader scale cases to investigate the practical applicability of applying process mining for patient-centered clinical pathway identification.

The process modularization and sequencing method is developed based on DSM through GA-based searching and enumeration two steps. And current studies focus on cluster healthcare services into modules by considering interrelationships between services. An optimization formulation can be proposed in the future by treating the sequence of process and cost of forming a module as optimization constraints. Healthcare services in the case study are based on a simple outpatient process. To test the proposed method on a more complicated process is necessary. Detailed analysis and systematic evaluation by medical professionals need to be carried out in the future.

The performance of developed bi-level GA-based algorithm for healthcare package configuration is evaluated by comparison between as-is and to-be scenarios. More rigorous performance will be validated through simulation experiments. And studies on comparing GA-based algorithms with other heuristic or exact solutions will be carried out in the future. In the case study, only one resource type is used for illustration. More types of resources and considerations on handling of constraints

among the resources (e.g. conflicts of availability) will be included in the future study.

This research has made some progresses to enable mass customization of healthcare services and will continue the work towards the actual implementation.

REFERENCES

1. Agrawal, R., Gunopulos, D. and Leymann, F. (1998). Mining process models from workflow logs, In: *Proceedings of the 6th International Conference on Extending Database Technology: Advances in Database Technology*, Valencia, Spain, March 23-27.
2. Amir-Aslani, A. and Mangematin, V. (2010). The future of drug discovery and development: Shifting emphasis towards personalized medicine. *Technological Forecasting and Social Change*, 77(2), 203-217.
3. Anderson, G. and Knickman, J.R. (2001). Changing the chronic care system to meet people's needs. *Health Affairs*, 20(6), 146-160.
4. Anderson, G. and Jane Horvath, M.H.S.A. (2002). *Chronic Conditions: Making the Case for Ongoing Care*. The Robert Wood Johnson Foundation. <http://www.rwjf.org/pr/product.jsp?id=14197>.
5. Anderson G. Chronic Care: Makin the Case Ongoing Care. Princeton, NJ: Robert Wood Johnson Foundation, 2010. Available at <http://www.rwjf.org/files/research/50968chronic.care.chartbook.pdf>.
6. Angelova, M. and Pencheva, T. (2011). Tuning Genetic Algorithm Parameters to Improve Convergence Time. *International Journal of Chemical Engineering*, 2011, 1-7.
7. Blendon, J.R., Schoen, C., Desroches, C., Osborn, R. and Zapert, K. (2003). Common concerns amid diverse systems: Health care experiences in five countries. *Health Affairs*, 22(3), 106-121.
8. Bodenheimer, T., Lorig, K., Holman, H. and Grumbach, K. (2002). Patient Self-management of Chronic Disease in Primary Care. *The Journal of the American Medical Association*, 288(19), 2469-2475.
9. Bodenheimer, T. (2008). Coordinating care - A perilous journey through the health care system. *The New England Journal of Medicine*, 358(10), 1064-1071.
10. Bohmer, R.M.J. (2005). Medicine's service challenge: Blending custom and standard care. *Health Care Management Review*, 30(4), 322-330.
11. Bohmer, R.M.J., & Lawrence, D.M. (2008). Care platforms: a basic building block for care delivery. *Health Affairs*, 27(5), 1336-1340.
12. Bohmer, R.M.J. (2009). *Designing care: aligning the nature and management of health care*, Boston, MA: Harvard Business Press.
13. Bose, R.P.J.C. and van der Aalst, W.M.P. (2009). Abstractions in Process Mining: A Taxonomy of Patterns. *Business Process Management*, 5701, 159-175.

14. Brandeau, M.L., Sainfort, F. and Pierskalla, W.P. (2004). Health care Delivery: Current problems and future challenges, In Brandeau, M.L., F. Sainfort, and W.P. Pierskalla Editors. *Operational Research and Health Care. A Handbook of Methods and Applications*, Boston, Kluwer Academic Publishers.
15. Browning, T.R. (2001). Applying the design structure matrix to system decomposition and integration problems: a review and new directions. *IEEE Transactions on Engineering management*, 48(3), 292-306.
16. Browning, T.R. and Yassine, A. (2010). Resource-constrained multi-project scheduling: Priority rule performance revisited. *International Journal of Production Economics*, 126(2), 212-228.
17. Brownstein, C.A., Brownstein, J.S., Williams, D.S., Wicks, P. and Heywood, J. (2009). The power of social networking in medicine. *Nature Biotechnology*, 27(10), 888–890.
18. Brucker, P., Drexl, A., Möring, R. Neumann, K. and Pesch, E. (1999). Resource-constrained project scheduling problem: Notation, classification, models and methods. *European Journal of Operational Research*, 112, 3-41.
19. Buntin, M.B., Damberg, C., Haviland, A., Kapur, K., Lurie, N., McDevitt, R. and Marquis, M.S. (2006). Consumer-directed health care: Early evidence about effects on cost and quality. *Health Affairs*, 25(6), 516-530.
20. Casalino, L., Devers, K.J. and Lake, T.K. (2003). Benefits of and barriers to large medical group practice in the United States. *Archives of Internal Medicine*, 163(16), 1958-1964.
21. Chao, S. (2003). Mass customization - The next generation of pharmacy management. *The American Journal of Managed Care*, Supplementary Decision Maker News, 5-7.
22. Chen, H. and Pau, L.F. (2010). Mass Customization in Wireless Communication Services: Individual Services and Tariffs. *Handbook of Research in Mass Customization and Personalization - Applications and Cases*, ed. F.T. Piller and M.M. Tseng. Vol. 2. New York: World Scientific Press.
23. Cho, S.H and Eppinger, S.D. (2005). A Simulation-Based Process Model for Managing Complex Design Projects. *IEEE Transactions on Engineering Management*, 52(3), 316-328.
24. Christensen, C.M., Bohmer, R. and Kenagy, J. (2000). Will disruptive innovations cure health care? *Harvard Business Review*, 78(5), 102-112.
25. Christensen, C.M., Grossman, J.H. and Hwang, J. (2009). *The Innovator's Prescription: A Disruptive Solution for Health Care*. McGraw-Hill, New York.

26. Christofides, N., Alvarez-Valdes, R. and Tamarft, M. (1987). Project Scheduling with Resource Constraints: A Branch and Bound Approach. *European Journal of Operational Research*, 29(3), 262-273.
27. Compare Gebala, D.A. and Eppinger, S.D. (1991). Methods for analyzing design procedures. In: *Proceedings of 3rd International ASME Conference on Design Theory and Methodology*, 227-233.
28. Cook, J.E. and Wolf, A.L. (1998), Discovering models of software processes from event-based data, *ACM Transactions on Software Engineering and Methodology*, 7(3), 215-49.
29. Cooper, E. (1999). Modular Assembly Lines Are Taking Over. *Machine Design*, 71(19), 97-102.
30. Da Silveira, G., Borenstein, D. and Fogliatto, F.S. (2001). Mass customization: Literature review and research directions. *International Journal of Production Economics*, 72(1), 1-13.
31. Davila, F. (2002). The future of American healthcare: a mandatory change to mass customization. *The American Journal of Managed Care*, Supplementary Decision Maker News, 5-6.
32. Davis, E.W. (1969). An Exact Algorithm for the multiple constrained- resource project scheduling problem. *Doctoral Thesis*, Yale University, New Haven, USA.
33. Davis, E.W. and Patterson, J.H. (1975). A comparison of heuristic and optimum solutions in resource constrained project scheduling. *Management Science*, 21(8), 944-955.
34. Davis, S.M. (1987). *Future Perfect*. Reading, MA: Addison-Wesley Publishing Company.
35. De Blok, C., Luijkx, K., Meijboom, B. and Schols, J. (2010). Modular care and service packages for independently living elderly. *International Journal of Operations & Production Management*, 30(1), 75 – 97.
36. De Blok, C., Meijboom, B., Luijkx, K. and Schols, J. (2013). The human dimension of modular care provision: Opportunities for personalization and customization. *International Journal of Production Economics*, 142(1), 16-26.
37. De Medeiros, A.K.A., van Dongen, B.F., van der Aalst, W.M.P. and Weijters, A.J.M.M. (2004). Process Mining for Ubiquitous Mobile Systems: An Overview and a Concrete Algorithm. In: Baresi, L., Dustdar, S., Gall, H.C., Matera, M. (eds.) UMICS. LNCS, 3272, 151–165. Springer, Heidelberg.
38. De Medeiros, A.K.A. (2006). Genetic Process Mining. PhD thesis, Eindhoven University of Technology, Eindhoven, The Netherlands.

39. De Medeiros, A.K.A., Weijters, A.J.M.M., and Van der Aalst, W.M.P. (2007). Genetic process mining: an experimental evaluation. *Data Mining and Knowledge Discovery*, 14(2), 245–304.
40. Demeulemeester, E. and Herroelen, W. (1992). A Branch-and bound procedure for the multiple resource-constrained project scheduling problem. *Management Science*, 38(12), 1803-1818.
41. Demeulemeester, E. and Herroelen, W. (1997). New benchmark results for the resource-constrained project scheduling problem. *Management Science*, 43, 1485-1492.
42. Denker, S., Steward, D. and Browning, T. (1999). Planning concurrency and managing iteration in projects. *Center for Quality of Management Journal*, 8(2), 55-62.
43. Dowd, B.E. (2005). Coordinated agency versus autonomous consumers in health services markets. *Health Affairs*, 24(6), 1501-1511.
44. Drake, M.V. and Lowenstein, D.H. (1998). The role of diversity in the health care needs of California. *Western Journal of Medicine*, 168 (5), 348–354.
45. Eddy, D.M. (2005). Evidence-Based Medicine: A Unified Approach. *Health Affairs*, 24(1), 9-17.
46. Eppinger, S.D., Whitney, D.E., Smith, R.P. and Gebala, D.A. (1991). Organizing the Tasks in Complex Design Projects. *Computer-Aided Cooperative Product Development*. D. Sriram and R. Logcher, ed. New York: Springer-Verlag, 229-252.
47. Eppinger, S.D., Whitney, D.E., Smith, R.P., and Gebala, D.A. (1994). A Model-Based Method for Organizing Tasks in Product Development. *Research in Engineering Design*, 6(1), 1-13.
48. Espinoza, F.P., Minsker, B.S. and Goldberg, D.E. (2005). Adaptive hybrid genetic algorithm for groundwater remediation design. *Journal of Water Resources Planning and Management*, 131(1), 14-24.
49. Eysenbach, G. and Diepgen, T.L. (2000). The role of e-health and consumer health informatics for evidence-based patient choice in the 21st century. *Clinics in Dermatology*, 19(1), 11-17.
50. Fernandez, C. I. G. (1998). Integration Analysis of Product Architecture to Support Effective Team Co-location. *Master's Thesis*, MIT Sloan School of Management.
51. Fitzsimmons, J.A. and Fitzsimmons, M.J. (2008). *Service management: Operations, strategy, information technology*. McGraw-Hill, New York.
52. Fogliatto, F.S., Da Silveira, G., Borenstein, D., (2012). The mass customization decade: An updated review of the literature. *International Journal of Production Economics*, 138 (1), 14-25.

53. Frei, F.X. (2006). *Customer-introduced variability in service operations*. Harvard Business School Publishing, Boston.
54. Goedertier, S., De Weerd, J., Martens, D., Vanthienen, J. and Baesens, B. (2011). Process Discovery in Event Logs: An application in the Telecom Industry. *Applied Soft Computing*, 11(2), 1697-1710.
55. Goldberg, D.E. (1989). *Genetic algorithms in search, optimization, and machine learning*. Reading, MA: Addison-Wesley.
56. Gupta, S. (2007). Workflow and process mining in healthcare, Master's thesis, Technische Universiteit Eindhoven.
57. Gurwitz, D. and Manolopoulos, V.G. (2007). Personalized medicine, in comprehensive medicinal chemistry II, B.T. John and J.T. David, Editors, Elsevier: Oxford, 279-295.
58. Harshbarger, M. and Bohmer, R. (1999). *Note on physician compensation and financial incentives*, Harvard Business School Publishing, Boston.
59. Haas, M., & Kunz, W. H. (Eds.). (2010). How to Master the Challenges of Service Mass Customization – A Persona-Based Approach (Vol. 2). Hackensack/London: World Scientific.
60. Hart, C.W.L. (1995). Mass customization: conceptual underpinnings, opportunities and limits. *International Journal of Service Industry Management*, 6(2), 36 – 45.
61. Herzlinger, R.E. (2002). Let's put consumers in charge of health care. *Harvard Business Review*, 80(7), 44-55.
62. Herzlinger, R.E. (2004). *Consumer-driven health care: implications for providers, payers, and policymakers*, San Francisco, Jossey-Bass.
63. Herzlinger, R.E. and Parsa-Parsi, R. (2004). Consumer-driven health care: Lessons from Switzerland. *The Journal of American Medical Association*, 292(10), 1213-1220.
64. Hillestad, R., Bigelow J., Bower A., Girosi F., Meili R., Scoville R. and Taylor R. (2005). Can electronic medical record systems transform health care? Potential health benefits, savings, and costs. *Health Affairs*, 24(5), 1103-1117.
65. Holland, J. (1975). *Adaptation in natural and artificial systems*. University of Michigan Press, Ann Arbor, Michigan.
66. Institute of Medicine (2001). *Crossing the quality chasm: a new health system for the 21st century*, National Academy Press, Washington, DC.
67. Jain, A., Murty, M. and Flynn, P. (1999). Data clustering: A review. *ACM Computing Surveys*, 31(3), 264-323.
68. Jiao, J., Ma, Q. and Tseng, M.M. (2003). Towards high value-added products and services: mass customization and beyond. *Technovation*, 23(10), 809-821.

69. Jimmerson, C., Weber, D. and Sobek, D.K. (2005). Reducing Waste and Errors: Piloting Lean Principles at Intermountain Healthcare. *Joint Commission Journal on Quality and Patient Safety*, 31(5), 249-257.
70. Johnson, T.J.R. (1967). An algorithm for the resource-constrained project scheduling problem, *Doctoral Dissertation*, MIT, Boston, USA.
71. Klein, R. and Scholl, A. (1999). Computing lower bound by destructive improvement: An application to resource-constrained project scheduling. *European Journal of Operational Research*, 112, 322-346.
72. Kusiak, A. and Wang, J. (1993). Efficient Organizing of Design Activities. *International Journal of Production Research*, 31(4), 753-769.
73. Kessler, D. and McClellan, M. (1996). Do Doctors Practice Defensive Medicine? *The Quarterly Journal of Economics*, 111(2), 353-390.
74. Kron, G. (1963). Diakoptics: The Piecewise Solution of Large-scale Systems, Macdonald, London.
75. Laiacona, C.M. (2001). Networking health: Prescriptions for the Internet. *Journal of Government Information*, 28(3), 303-305.
76. Lang, M., BÄurkle, T., Laumann, S., Prokosch, H.U. (2008). Process mining for clinical workflows: Challenges and current limitations. In Andersen, S., ed.: *eHealth Beyond the Horizon*, IOS Press (2008) 229-234.
77. Lenz, R. and Kuhn, K.A. (2004). Towards a continuous evolution and adaptation of information systems in healthcare. *International journal of medical informatics*, 73(1), 75-89.
78. Lenz, R. and Reichert, M. (2007). IT support for healthcare processes - premises, challenges, perspectives. *Data & Knowledge Engineering*, 61(1), 39-58.
79. Levitt, T. (1972). Production-line approach to service. *Harvard Business Review*, 50(5), 41-52.
80. Lin, W.Y., Lee, W.Y. and Hong, T.P. (2003). Adapting crossover and mutation rates in genetic algorithms. *Journal of Information Science and Engineering*, 19, 889-903.
81. Makoul, G., Curry, R.I.I., and Tang, P.C. (2001). The use of electronic medical records: Communication patterns in outpatient encounters. *Journal of the American Medical Informatics Association*, 8(6), 610-615.
82. Mans, R., Schonenberg, H., Leonardi, G., Panzarasa, S., Cavallini, A., Quaglini, S. and Van der Aalst, W. (2008). Process mining techniques: An application to stroke care. *Studies in Health Technology and Informatics*, 136, 573-578.
83. Mans, R.S., Aalst, W.M.P., Russell, N.C. and Bakker, P.J.M. (2009). Flexibility Schemes for Workflow Management Systems. In *Business Process Management*

- Workshops*. vol. 17, W. Aalst, J. Mylopoulos, M. Rosemann, M. J. Shaw, and C. Szyperski, Eds.: Springer Berlin Heidelberg, 361-372.
84. McCarthy, M. (2006). Can car manufacturing techniques reform health care? *The Lancet*, 367(9507), 290-291.
 85. McCulley, C., Hulme, K.F., and Bloebaum, C.L. (1997). Simulation-Based Development of Heuristic Strategies for Complex System Convergence. *Applied Mechanics Review*, 50(11S), 117-124.
 86. McDaniel, A.M., Schutte, D.L. and Keller, L.O. (2008). Consumer health informatics: From genomics to population health. *Nursing Outlook*, 56(5), 216-223.
 87. McLaughlin, C.P. and Kaluzny, A.D. (2000). Building Client Centered Systems of Care: Choosing a Process Direction for the Next Century. *Health Care Management Review*, 25(1), 73-82.
 88. Meyer, M.H. and DeTore, A.D. (1999). Product Development for Services. *Academy of Management Executive*, 13(3), 64-76.
 89. Meyer, M.H. and Detore, A.D. (2001). Creating Platform-based Approaches to New Services Development. *Journal of Product Innovation Management*, 18, 188-204.
 90. Meyer, M.H., Jekowsky, E. and Crane, F.G. (2007). Applying platform design to improve the integration of patient services across the continuum of care. *Managing Service Quality*, 17(1), 23 - 40.
 91. Miller, J., (1978). The body in question. *Random House*, New York.
 92. Miller, R.H. and Luft, H.S. (1994). Managed care plan performance since 1980. *The Journal of the American Medical Association*, 271(19), 1512-1519.
 93. Mingozzi, A., Maniezzo, V., Ricciardelli, S. and Bianco, L. (1998). An exact algorithm for the multiple resource-constrained project scheduling problem based on a new mathematical formulation. *Management Science*, 44, 714-729.
 94. Mohanty, R.P., and Siddiq, M.K. (1989). Multiple projects-multiple resources constrained scheduling: Some studies. *International Journal of Operation Research*, 27 (2), 261-280.
 95. Moon, S.K., Simpson, T.W., Shu, J. and Kumara, S.R.T. (2009). Service Representation for Capturing and Reusing Design Knowledge in Product and Service Family using Object-Oriented Concepts and an Ontology. *Journal of Engineering Design*, 20(4), 413-431.
 96. Moon, S.K., Shu, J., Simpson, T.W. and Kumara, S.R.T. (2011). A Module-based Service Model for Mass Customization: Service Family Design. *IIE Transactions*, 43(3), 153-163.

97. Patterson, J.H. and Huber, W.D. (1974). A horizon-varying, zero-one approach to project scheduling. *Management Science*, 20(6), 990-998.
98. Patterson, J.H., Sowinski, R., Talbot, F.B., and Weglarz, J. (1989). An algorithm for a general class of precedence and resource constrained scheduling problems, in: R. Sowinski, J. Weglarz (Eds.), *Advances in Project Scheduling*, Elsevier, Amsterdam, 3-28.
99. Pekkarinen, S. and Ulkuniemi, P. (2008), Modularity in developing business services by platform approach. *International Journal of Logistics Management*, 19(1), 84-103.
100. Piette, J.D. and Kerr, E.A. (2006). The Impact of Comorbid Chronic Conditions on Diabetes Care. *Diabetes Care*, 29(3), 725-731.
101. Piller, F.T., Schubert, P., Koch, M. and Moeslein, K. (2004). From mass customization to collaborative customer co-design. *ECIS 2004 Conference*, Finland.
102. Piller, F. and Kumar, A. (2006). Mass customization & financial services: Providing custom products and services with mass production efficiency. *Journal of Financial Transformation*, Special Issue on "The Finance Factory", 18, 125-131.
103. Piller, F. T., & Tseng, M. M. (2010). Handbook of research in mass customization and personalization (Vol. 2): World Scientific.
104. Pimmler, T.U. and Eppinger, S.D. (1994). Integration Analysis of Product Decompositions. In: *Proceedings of ASME Conference on Design Theory and Methodology*, Minneapolis, MN, September 1994, pp. 343-351.
105. Pine, B.J. (1993). Mass customizing products and services. *Strategy & Leadership*, 21(4), 6 - 55.
106. Pine, B.J., Victor, B. and Boynton, A.C. (1993). Making Mass Customization Work. *Harvard Business Review*, 71(5), 108-118.
107. Pine, B.J., Gilmore, J.H. (2001). Welcome to the experience economy. *Health Forum Journal*, 44(5), 10-16.
108. Porter, M.E. and Teisberg, E.O. (2004). Redefining Competition in Health Care. *Harvard Business Review*, 82(6), 64-76.
109. Porter, M.E. and Teisberg, E.O. (2006). *Redefining health care: creating value-based competition on results*. Boston, MA: Harvard Business School Press.
110. Powell, P.T. and Laufer, R. (2010). The promises and constraints of consumer-directed healthcare. *Business Horizons*, 53(2), 171-182.
111. Pritsker A.A.B., Watters, W.D. and Wolfe, P.M. (1969). Multiproject scheduling with limited resources: a zero-one programming approach. *Management Science*, 16, 93-108.

112. Qu, X. and Shi, J. (2011). Modeling the effect of patient choice on the performance of open access scheduling. *International Journal of Production Economics*, 129(2), 314-327.
113. Reeves, C. (1995). A genetic algorithm for flowshop sequencing. *Computers & Operations Research*, 22, 5-13.
114. Reid, P.P., Compton, W.D., Grossman, J.H. and Fanjiang, G. (2005). *Building a better delivery system: a new engineering/health care partnership*. Washington, D.C.: National Academies Press
115. Robert, J., Vekris, A., Pourquier, P., and Bonnet, J. (2004). Predicting drug response based on gene expression. *Critical Reviews in Oncology/ Hematology*, 51(3), 205-227.
116. Rogers, J., McCulley, C.M. and Bloebaum, C.L. (1999). Optimizing the Process Flow of Complex Design Projects. *Design Optimization, International Journal for Product and Process Improvement*, 1(3), 281-292.
117. Rozinat, A., De Medeiros, A. K. A., Gunther, C. W., Weijters, A. J. M. M. and Van Der Aalst, W. M. P. (2007). The need for a process mining evaluation framework in research and practice. In *Business Process Management Workshops*. vol. 4928: Springer Berlin Heidelberg, pp. 84-89.
118. Rozinat, A., Mans, R.S., Song, M., and Van der Aalst, W.M.P. (2008). "Discovering colored Petri nets from event logs." *International Journal on Software Tools for Technology Transfer (STTT)* 10(1): 57-74.
119. Sackett, D.L., Rosenberg, W.M.C., Gray, J.A.M., Haynes, R. B. and Richardson, W.S. (1996). Evidence based medicine: what it is and what it isn't, *British Medical Journal*, 312(7023), 71-72.
120. Scandlen, G. (2005). Consumer-driven health care: Just a tweak or a revolution? *Health Affairs*, 24(6), 1554-1558.
121. Scott, J. A. (1999). A strategy for modeling the design-development phase of a product. *Doctoral Thesis*, Department of Marine Technology, University of Newcastle upon Tyne, UK.
122. Scott, W.R., Ruef, M., Mendel, P.J. and Caronna, C.A. (2000). *Institutional Change and Healthcare Organizations: From Professional Dominance to Managed Care*. Chicago, IL: The University of Chicago Press.
123. Shih, A.J. (2008). Biomedical Manufacturing: A New Frontier of Manufacturing Research. *Journal of Manufacturing Science and Engineering*, 130(2), 021009-8.
124. Shortell S.M., O'Brien J.L., Carman J.M., Foster R.W., Hughes E.F., Boerstler H. and O'Connor E.J. (1995). Assessing the impact of continuous quality improvement/total

- quality management: concept versus implementation. *Health Service Research*, 30(2), 377–401.
125. Smits, H., Zarowitz, B., Sahney, V.K., and Savitz, L. (2003). The Business Case for Pharmaceutical Management: A Case Study of Henry Ford Health System, The Commonwealth Fund, April 2003.
 126. Steward, D.V. (1981). The design structure system: A method for managing the design of complex systems. *IEEE Transactions on Engineering Management*, 28(3), 71-74.
 127. Steward, D. (1991). Planning and managing the design of systems. In: *Proceedings of Portland International Conference on Management of Engineering and Technology*, Portland, OR, USA, 27-31 October.
 128. Stille, C.J., McLaughlin, T.J., Primack, W.A., Mazor, K.M., and Wasserman, R.C. (2006). Determinants and impact of generalist-specialist communication about pediatric outpatient referrals. *Pediatrics*, 118(4), 1341-1349.
 129. Stinson, J.P., Davis, E.W., and Khumawala, B.M. (1978). Multiple resource-constrained scheduling using branch and bound. *AIIE Transaction*, 10(3), 252-259.
 130. Sundbo, J. (1994). Modulization of service production and a thesis of convergence between service and manufacturing organizations. *Scandinavian Journal of Management*, 10(3), 245-266.
 131. Talbot, F.B. (1982). Resource-constrained project scheduling with time-resource tradeoffs: The non-preemptive case. *Management Science*, 28(10), 1197-1210.
 132. Thebeau, R.E. (2001). Knowledge Management of System Interface and Interactions for Product Development Processes. *Master's Thesis*, MIT.
 133. Tinetti M.E., Bogardus S.T., and Agonstini J.V. (2004). Potential pitfalls of disease-specific guidelines for patient with multiple conditions. *The New England Journal of Medicine*, 351(28), 2870-2874.
 134. Tiwari, A., Turner, C.J., and Majeed, B. (2008). A review of business process mining: state-of-the-art and future trends. *Business Process Management Journal*, 14(1), 5 – 22.
 135. Toffler, A. (1970). *Future shock*. New York: Random House.
 136. Tseng, M.M., Jiao, J., and Merchant, M.E. (1996). Design for Mass Customization, *CIRP Annals - Manufacturing Technology*, 45(1), 153-156.
 137. Van der Aalst, W., Weijters, A., and Maruster, L. (2004). Workflow Mining: Discovering Process Models from Event Logs. *IEEE Transactions on Knowledge and Data Engineering*, 16 (9), 1128-1142.
 138. Van der Aalst, W.M.P., Reijers, H.A., Weijters, A.J.M.M., Van Dongen, B.F., Alves de Medeiros, A.K., Song, M. and Verbeek, H.M.W. (2007). Business process mining: An industrial application. *Information Systems*, 32(5), 713-732.

139. Van der Aalst, W.M.P., Van Dongen, B.F., Günther, C.W., Mans, R.S., Alves de Medeiros, A.K., Rozinat, A., Rubin, V., Song, M., Verbeek, H.M.W. and Weijters, A.J.M.M. (2007). ProM 4.0: Comprehensive Support for Real Process Analysis. In: *Petri Nets and Other Models of Concurrency – ICATPN 2007*. vol. 4546: Springer Berlin / Heidelberg, 484-494.
140. Van der Aalst, W. (2011). *Process Mining: Discovery, Conformance and Enhancement of Business Processes*. Springer Verlag, Berlin (ISBN 978-3-642-19344-6).
141. Van Dongen, B.F., Alves de Medeiros, A.K., and Wen, L. (2009). Process mining: Overview and outlook of petri net discovery algorithms. *Transactions on Petri Nets and Other Models of Concurrency II*. K. Jensen and W. van der Aalst, Springer Berlin / Heidelberg. 5460, 225-242.
142. Vogeli, C., Shields, A.E., Lee, T.A., Gibson, T.B., Marder, W.D., Weiss, K.B. and Blumenthal, D. (2007). Multiple chronic conditions: prevalence, health consequences, and implications for quality, care management, and costs. *Journal of General Internal Medicine*, 22, Supplement 3, 391-395.
143. Weijters, A.J.M.M., and van der Aalst, W.M.P. (2003). Rediscovering Workflow Models from Event-Based Data using Little Thumb. *Integrated Computer-Aided Engineering*, 10(2), 151–162.
144. Weijters, A.J.M.M., van der Aalst, W.M.P., and Alves de Medeiros, A.K. (2006). Process Mining with Heuristics Miner Algorithm. BETA Working Paper Series, WP 166, Eindhoven University of Technology, Eindhoven.
145. Wen, L., Wang, J., van der Aalst, W.M.P., Wang, Z., and Sun, J. (2004). A Novel Approach for Process Mining Based on Event Types. BETA Working Paper Series, WP 118, Eindhoven University of Technology, Eindhoven.
146. Wennberg J. and Gittelsohn A. (1973). Small area variations in health care delivery. *Science*, 182(117), 1102-1108.
147. Whitfield, R.I., Smith, J.S. and Duff, A.H.B. (2002). Identifying component modules. *Artificial Intelligence in Design*, Cambridge, UK.
148. Wiest, J.D. (1967). A Heuristic Model for Scheduling Large Projects with Limited Resources. *Management Science*, 13(6), Series B, 359-337.
149. Wilensky, G.R. (2006). Consumer-driven health plans: early evidence and potential impact on hospitals. *Health Affairs*, 25(1), 174-185.
150. World Health Organization. (2000). The world health report 2000 - Health systems: improving performance. http://www.who.int/whr/2000/en/whr00_en.pdf.
151. World Health Organization. (2006). The World Health Report 2006 - working together for health. http://www.who.int/whr/2006/whr06_en.pdf.

152. Worthington, D.J. (1991). Hospital waiting list management models. *The Journal of the Operational Research Society*, 42(10), 833-843.
153. Xu, Q. and Jiao, J.R. (2009a). Modeling the Design Process of Product Variants with Timed Colored Petri Nets. *ASME Journal of Mechanical Design*, 131(6), 061009/1-9.
154. Xu, Q. and Jiao, J.R. (2009b). Design Project Modularization for Product Families. *ASME Journal of Mechanical Design*, 131(7), 071007/1-10.
155. Xu, R. and Wunsch, D. (2005). Survey of clustering algorithms. *IEEE Transactions on Neural Networks*, 16(3), 645-678.
156. Yassine, A. (2004). An introduction to modeling and analyzing complex product development processes using the Design Structure Matrix (DSM) method. *Italian Management Review*, www.quaderni-di-management.it, No.9.
157. Zipkin, P. (2001). The Limits of Mass Customization. *MIT Sloan Management Review*, 42(3), 81-87.

APPENDIX

Appendix A – An Example of EMRs and Structural Information from TTSH

SERIAL	DATE	SP_DESC	DRCODE	APP_T1	ARR_T1	ATT_T1	LEFT_T1	R11_TYP	CONST_T1	LEFT_CON	ATT_T2	LEFT_T2	R11_TYP	REWD_T1	LCON_T1	ST_T1	END_T1
4762	2009-5-4	03-Cardiology	04524A	12:00	12:20			00:00	12:35	12:40	00:05						
4763	2009-5-4	03-Cardiology	04524A	11:30	11:50			00:00	12:05	12:15	00:10						
4764	2009-5-4	03-Cardiology	04524A	11:50	11:26			00:00	11:45	11:50	00:05						
4765	2009-5-4	03-Cardiology	04524A	10:20	10:10	10:23	10:24	00:01	11:00	11:10	00:10						
4766	2009-5-4	03-Cardiology	04524A	11:30	11:25			00:00	11:40	11:45	00:05						
4767	2009-5-4	03-Cardiology	04524A	11:20	11:21			00:00	11:35	11:40	00:05						
4768	2009-5-4	03-Cardiology	04524A	10:40	09:25	09:30	09:35	00:05	11:20	11:25	00:05						
4769	2009-5-4	03-Cardiology	04524A	10:05	09:45	09:46	09:47	00:01	10:10	10:15	00:05						
...																	
4772	2009-5-4	03-Cardiology	04524A	10:15	09:46	09:50	09:51	00:01	10:15	10:25	00:10						
4773	2009-5-4	03-Cardiology	04524A	10:35	10:22	10:22	10:30	00:08	10:35	10:40	00:05	10:40	10:45	00:05	10:55	11:00	00:05
4775	2009-5-4	03-Cardiology	04524A	10:30	10:04	10:13	10:21	00:08	10:25	10:35	00:10						
4776	2009-5-4	03-Cardiology	04524A	09:40	09:23	09:25	09:26	00:01	10:00	10:05	00:05						
4779	2009-5-4	03-Cardiology	08310J	09:00	08:35	08:35	08:40	00:05	09:55	10:30	00:35						
...																	

Column No.	Variable	Code & Description
1	SERIAL	Serial Number
2	DATES	Date (yyyy-mm-dd)
3	SP_DESC	Specialty
		03 - Cardiology
		04 - Cardiothoracic Surgery
		05 - Colorectal Surgery
		...
		08 - Endocrinology
		09 - ENT
		10 - Eye
4	DRCODE	Doctor MCR number
5	APP_T1	Appointment time given to patient
6	ARR_T1	Time patient arrived for Registration/ given Room "Q" number
7	ATT_T1	Time patient attended by Nurse Clinician or staff from "Investigation/ Procedure" room
8	LEFT_T1	Time patient left the Nurse Clinician or "Investigation/ Procedure" room
9/14	R11_TYP	If patient went for "Investigation/ Procedure" prior consultation, please specify the type of
		01 - A Scan
		02 - B Scan
		03 - FFA (Fundus Flourescein Angiography)
		04 - GVF
		05 - HVF (Humphrey Visual Field Testing)
		06 - ICG
		07 - Laser Procedure
		08 - Orthoptist Assessment
		09 - Refraction
		10 - ECG (Electrocardiography)
		11 - X-Ray
		12 - Blood/ Lab Test
		13 - TOC
		14 - URO/RU
		15 - U Combur 9
		16 - Financial Con./Patient Edu.
		99 - Others
10	CONST_T1	Time patient first contact with
11	LEFT_CON	Time patient left the Consultation room
12	ATT_T2	Time patient attended by Nurse Clinician or staff in "Investigation/ Procedure" room
13	LEFT_T2	Time patient left the Nurse Clinician or "Investigation/ Procedure" room
15	REWD_T1	Time patient seen by doctor for review
16	LCON_T1	Time patient left the Consultation room
17	ST_T1	Start Time patient attended by billing / appointment staff
18	END_T1	End Time patient attended by billing / appointment staff

Appendix B – Heuristic Nets of Process Models

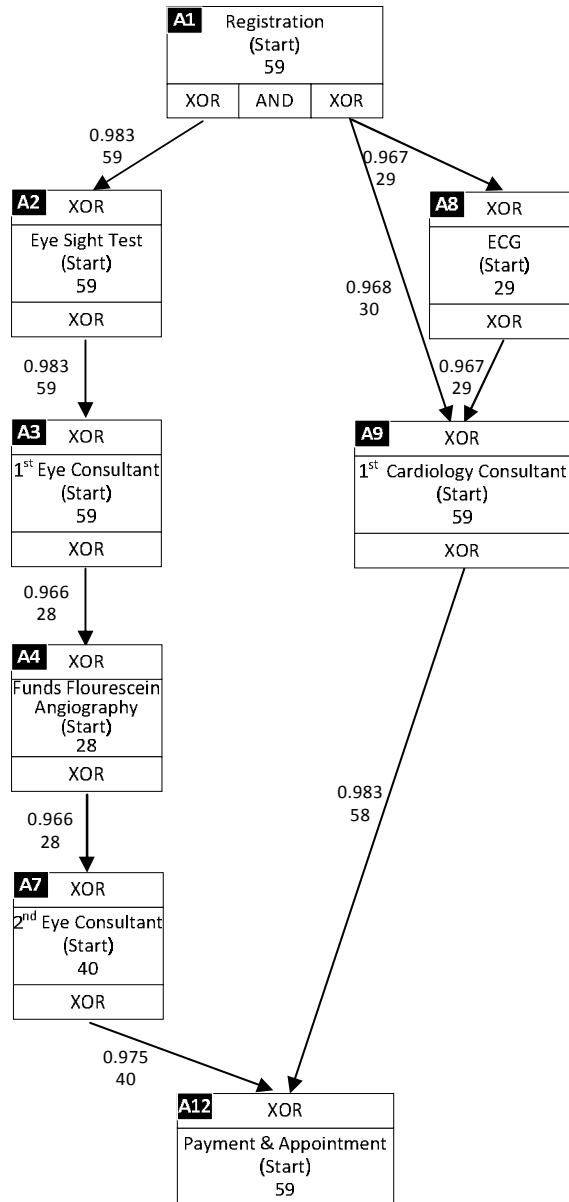

Figure B.1: A heuristic net representation of process model with dependency threshold 0.95

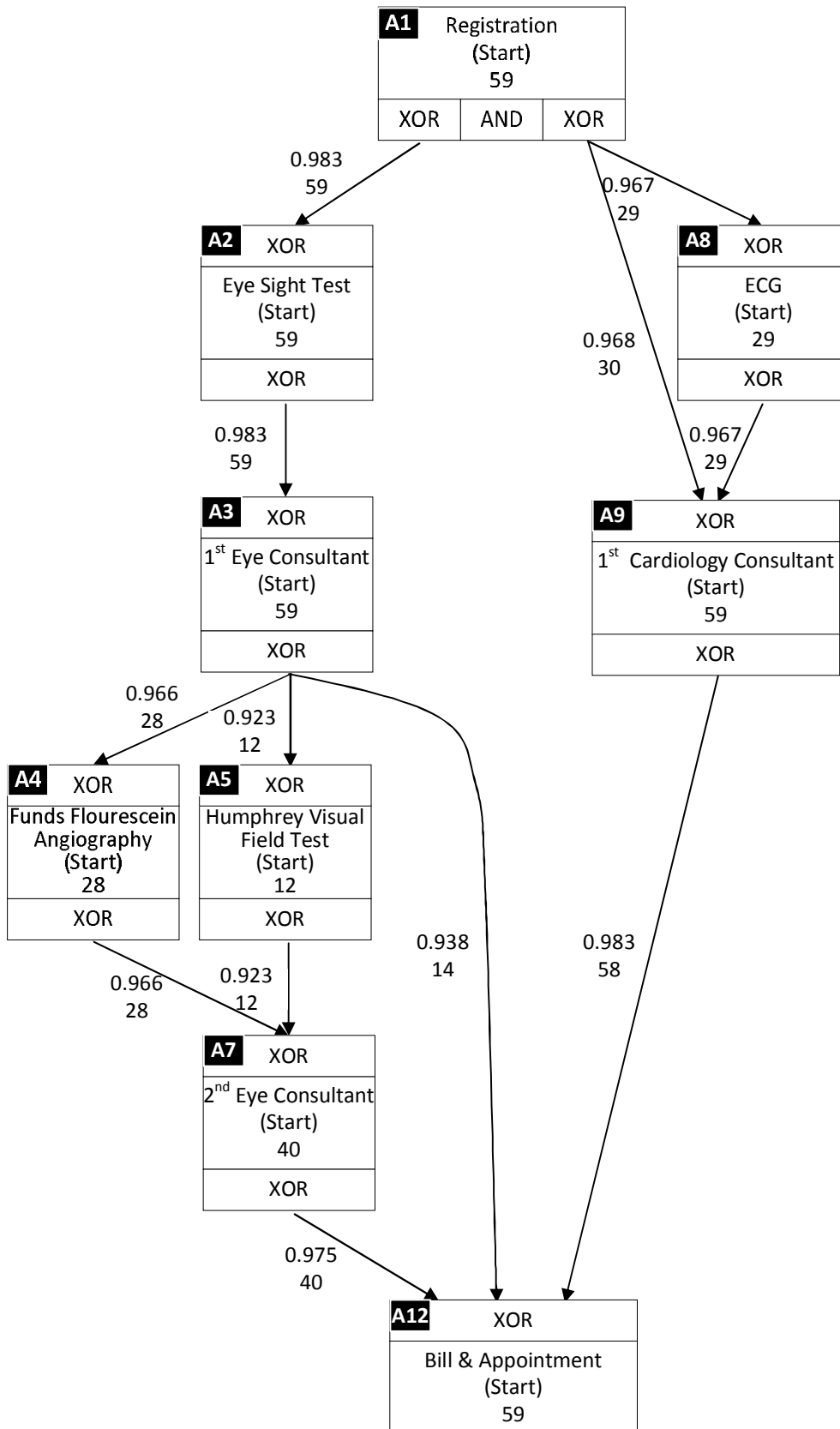

Figure B.2: A heuristic net representation of process model with dependency threshold 0.90

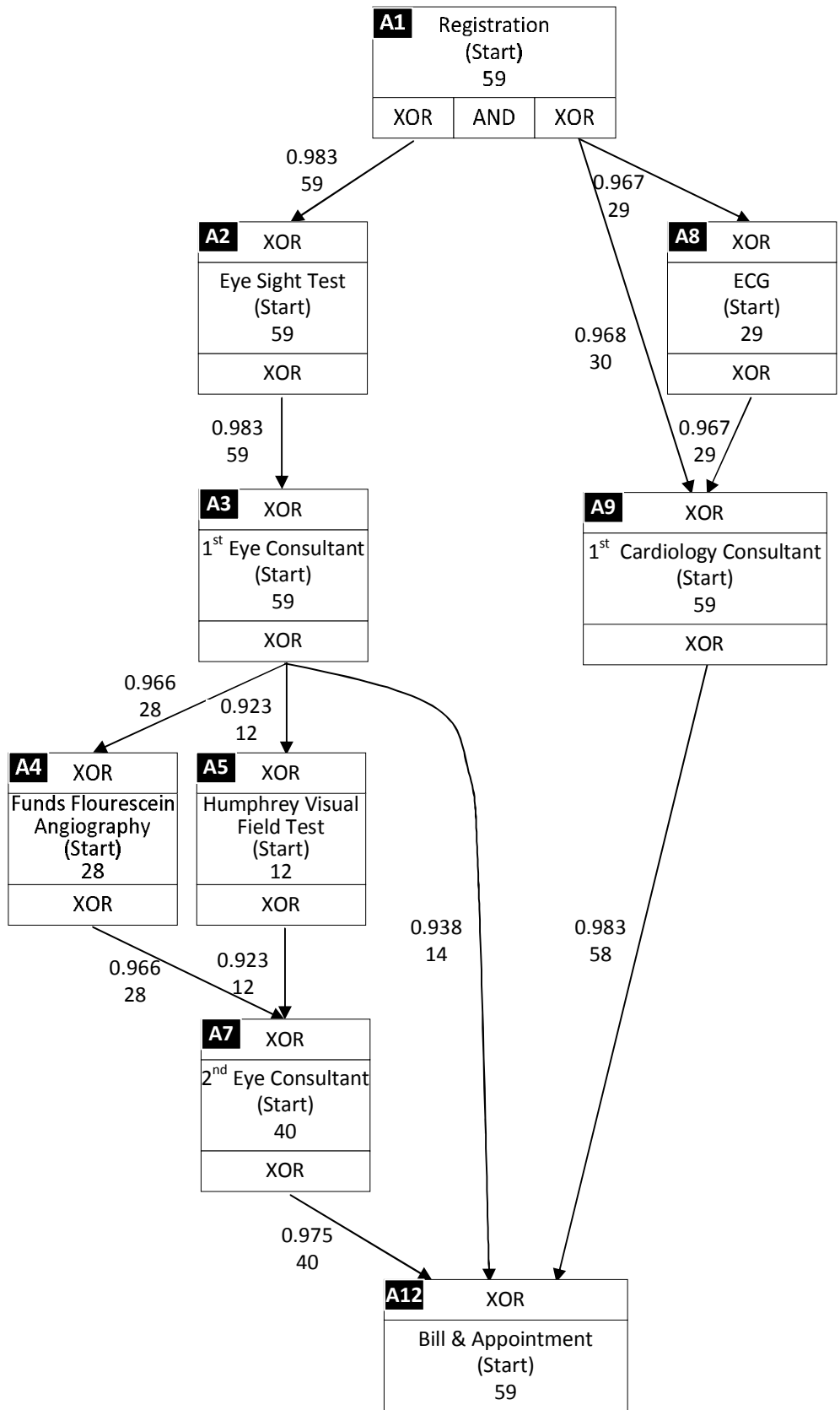

Figure B.3: A heuristic net representation of process model with dependency threshold 0.85

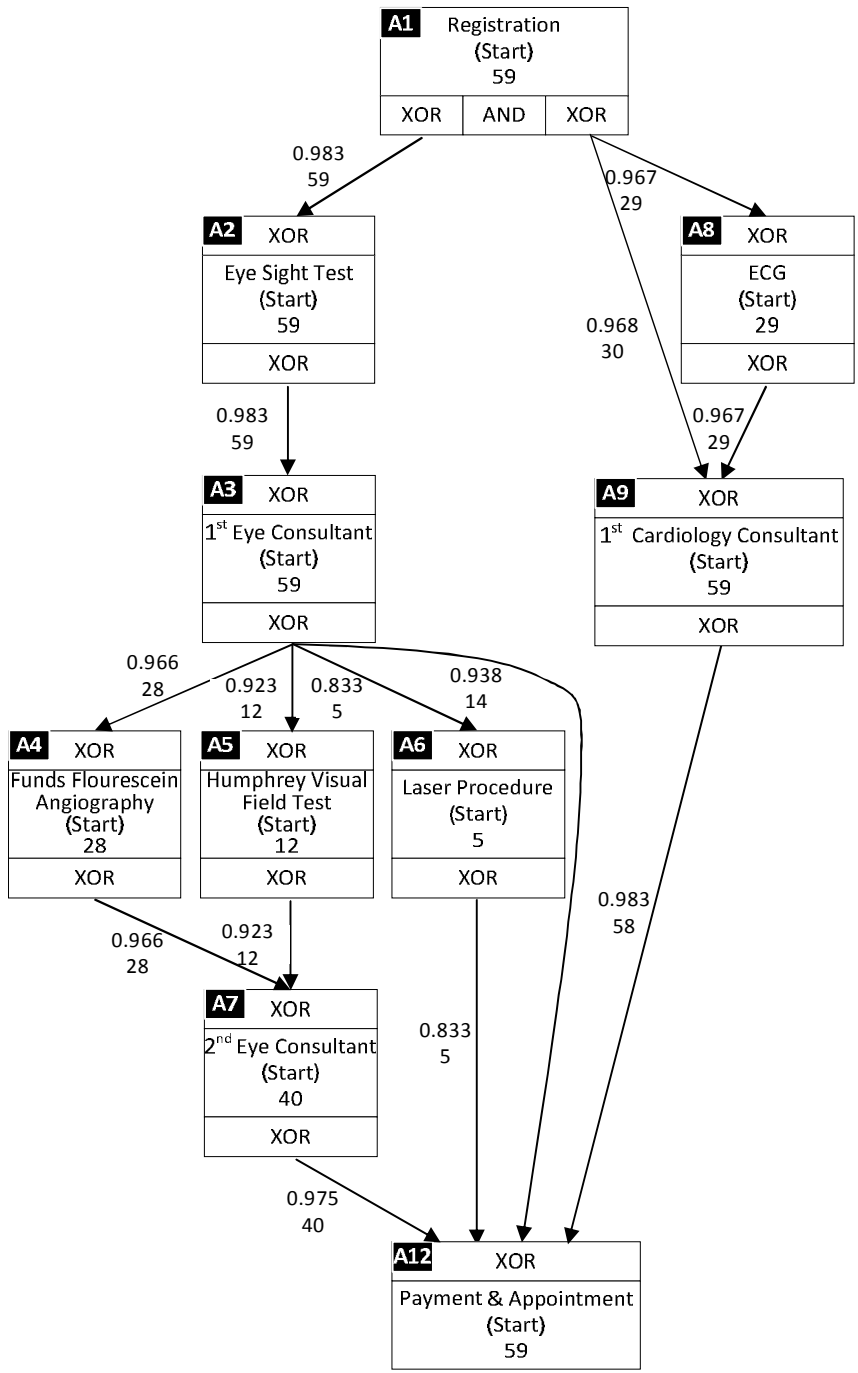

Figure B.4: A heuristic net representation of process model with dependency threshold 0.80

Appendix C – Petri Nets of Process Models

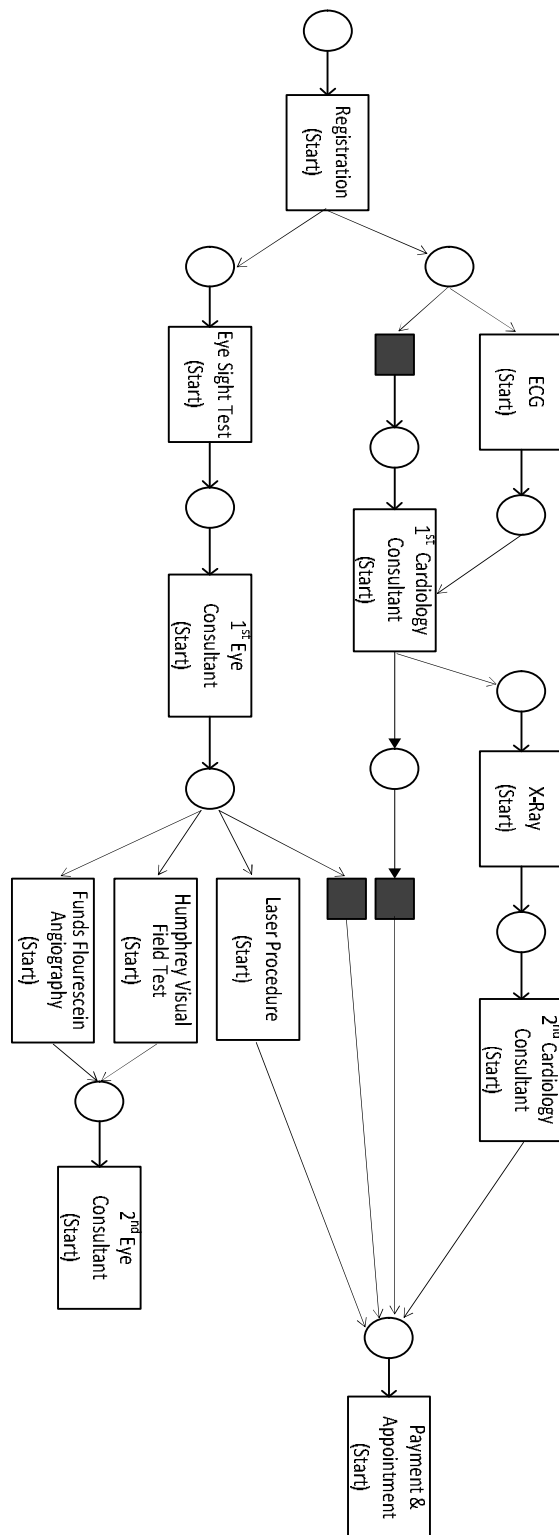

Figure C.1: A heuristic net representation of process model with all-activity-connected

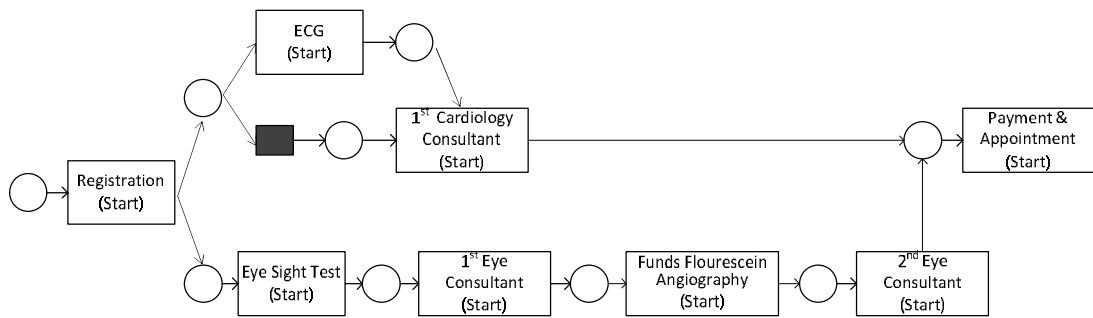

Figure C.2: A heuristic net representation of process model with dependency threshold 0.95

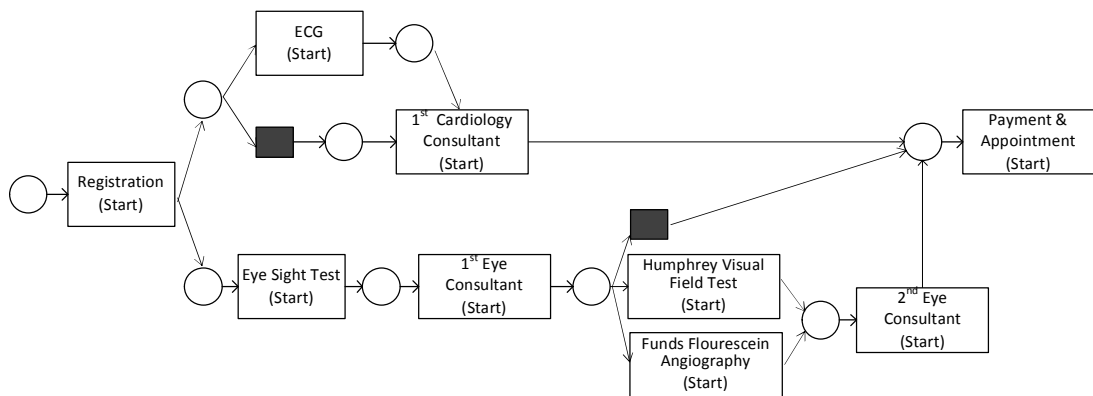

Figure C.3: A heuristic net representation of process model with dependency threshold 0.9

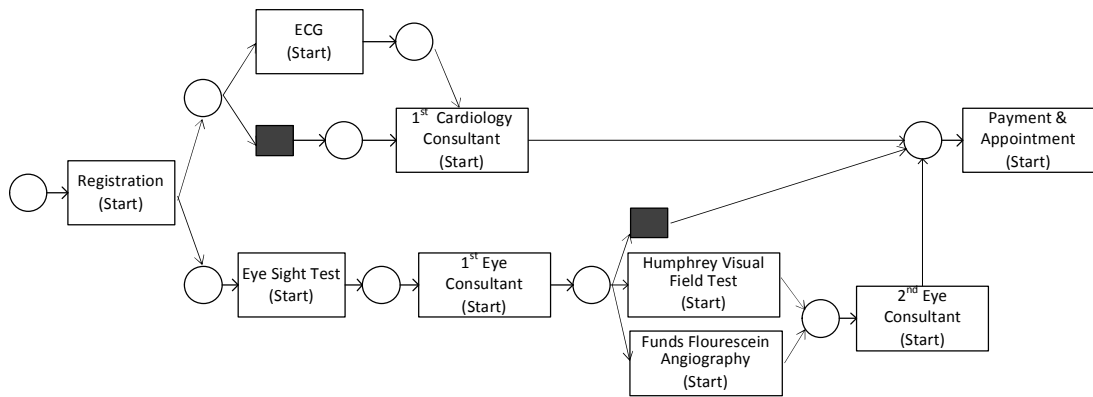

Figure C.4: A heuristic net representation of process model with dependency threshold 0.85

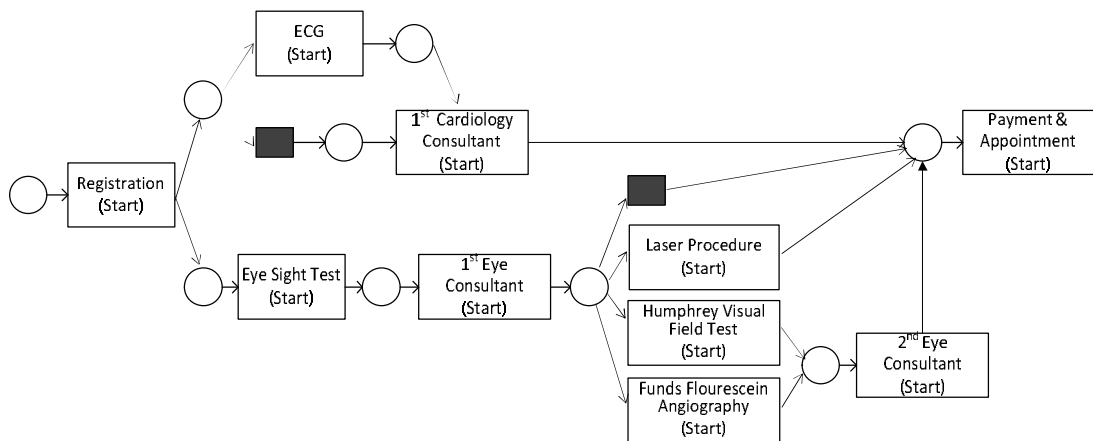

Figure C.5: A heuristic net representation of process model with dependency threshold 0.8

Appendix D – The code of GA-based clustering and sequencing algorithm

```
%%%%%%%%%%%%%%%%%%%%%%%%%%%%%%%%%%%%%%%%%%%%%%%%%%%%%%%%%%%%%%%%%%%%%%%%%%
%
% Description: Genetic Algorithm
%
%%%%%%%%%%%%%%%%%%%%%%%%%%%%%%%%%%%%%%%%%%%%%%%%%%%%%%%%%%%%%%%%%%%%%%%%%%

function [y costhistory] =
optimize_genetic_algorithm(objective_function, gene_length, gene_size,
population_size, min_generation, max_generation, epsilon, display_info)

% set default parameters if they are ignored
if nargin <= 2; gene_size = 1; end;
if nargin <= 3; population_size = 50; end;
if nargin <= 4; min_generation = 30; end;
if nargin <= 5; max_generation = 100; end;
if nargin <= 6; epsilon = 0.01; end;
if nargin <= 7; display_info = 1; end;

% set random seed
helper_random_seed_stack('save', 89123);

% initialize population
y = [];
gene_cache = [];
costhistory=[];
costsum=[];

for i = 1:population_size
    solution = ceil(rand(1, gene_length) * gene_size);
    gene = calculate_gene_cost(objective_function, solution,
gene_cache);
    y = [y gene];

    if display_info == 1
        disp(sprintf('ga individual %d: %f %s', i, gene.cost,
helper_strcat_vector(gene.solution)));
        costsum = [costsum; gene.cost];
    end
    costhistory = costsum;
end
u = y; % trial vectors, clones from y (deep copy, not reference)

% evolution
for generation = 1:(max_generation - 1)
    % sort solutions by costs
    for i = 1:size(y, 2)
        t = i;
        for j = (i + 1):size(y, 2)
            if y(j).cost < y(t).cost; t = j; end;
        end

        if t > i
            gene = y(i);
            y(i) = y(t);
            y(t) = gene;
        end
    end
end
```

```

    end
end

if display_info == 1 % output optima
    optima = y(1);
    disp(sprintf('cost: %f', optima.cost));
    disp(sprintf('solution: %s',
helper_strcat_vector(helper_remove_zeros(optima.solution))));
    disp(sprintf('data: %s', helper_strcat_vector(optima.data)));
end

% converged?
if i > min_generation
    sum_cost = 0;
    for i = 1:size(y, 2)
        sum_cost = sum_cost + y(i).cost;
    end
    diff = abs(sum_cost / population_size - y(1).cost);
    if diff < epsilon; break; end;
end

% evolution
costsum1=[];

for i = 1:population_size
    trial = u(i).solution;

    r = i;
    while (r == i)
        for j = 1:population_size
            if rand < 0.1
                r = j;
                break;
            end
        end
    end

    crossover_gene = y(r);
    old_gene       = y(i);

    j_rand = ceil(gene_length * rand) + 1;
    for j = 1:gene_length
        % crossover
        if (j == j_rand || rand < 0.9)
            trial(j) = crossover_gene.solution(j);
        else
            trial(j) = old_gene.solution(j);
        end

        % mutate
        if (rand < 0.1)
            old_block = trial(j);
            while old_block == trial(j)
                trial(j) = ceil(rand * (gene_size + 1));
            end
        end
    end
end
% end of mutation & recombination

```

```

    % evaluate the trial solution
    u(i) = calculate_gene_cost(objective_function, trial, gene_cache);

    if display_info == 1
        disp(sprintf('ga %d trial %d: %f %s', generation, i, u(i).cost,
helper_strcat_vector(trial)));
        costsum1(i) = [u(i).cost];
    end
    costhistory = [costhistory; costsum1(i)];
end
% end of calculation for trial vectors

% selection
successful_updates = 0;
for i = 1:population_size
    if u(i).cost <= y(i).cost
        y(i) = u(i);
        successful_updates = successful_updates + 1;
    end
end

if display_info == 1
    disp(sprintf('one evolution cycle ended. successful updates: %d',
successful_updates));
end
% end of the main iteration

if display_info == 1
    disp('genetic algorithm finished calculation.');
```

```

end

helper_random_seed_stack('restore', 89123);

return;
```

```

function y = calculate_gene_cost(objective_function, solution,
gene_cache)
for i = 1:size(gene_cache, 2)
    if sum(gene_cache(i).solution - solution) == 0
        y = gene_cache(i);
        return;
    end
end
```

```

y = Gene;
y.solution = solution;
[y.cost, y.data] = objective_function(solution);
```

```

gene_cache = [y gene_cache];
if size(gene_cache, 2) > 3000
    gene_cache = gene_cache(1:3000);
end
```

```

return;
```

```

%%%%%%%%%%%%%%%%%%%%%%%%%%%%%%%%%%%%%%%%%%%%%%%%%%%%%%%%%%%%%%%%%%%%%%%%%
```

```

%
% Description: function of helper in Genetic Algorithm
%
%%%%%%%%%%%%%%%%%%%%%%%%%%%%%%%%%%%%%%%%%%%%%%%%%%%%%%%%%%%%%%%%%%%%%%%%
function helper_random_seed_stack(method, random_seed)
    persistent history_seeds; if isempty(history_seeds); history_seeds =
    []; end;

    if strcmp(method, 'clear')
        while length(history_seeds) > 0; helper_random_seed_stack('restore',
1); end;
    end

    if nargin <= 1 || isempty(random_seed) || random_seed <= 0; return; end;

    if strcmp(method, 'init')
        helper_random_seed_stack('clear');
        helper_random_seed_stack('save', random_seed);
    end

    if strcmp(method, 'save')
        renv.rs = rand('state'); renv.ns = randn('state');
        history_seeds = [history_seeds, renv];
        rand('state', random_seed); randn('state', random_seed);
    end

    if strcmp(method, 'restore')
        hist_len = length(history_seeds);
        if hist_len == 0; return; end;
        renv = history_seeds(hist_len);
        rand('state', renv.rs); randn('state', renv.ns);
        history_seeds(hist_len) = [];
    end

function y = helper_remove_zeros(x)
    y = [];
    for i = 1:size(x, 2)
        if x(i) > 0; y = [y x(i)]; end;
    end
    return;

function y = helper_strcat_vector(v, precision)
    if nargin <= 1; precision = 10; end;
    str_format = sprintf('%d', precision);
    str_format = ['%6' '.' str_format 'f'];
    ret = '';
    for i = 1:(size(v, 2) - 1)
        ret = [ret, sprintf(str_format, v(i)), ',', ' '];
    end
    if size(v, 2) > 0
        ret = [ret, sprintf(str_format, v(size(v, 2)))];
    end
    y = ret;

%%%%%%%%%%%%%%%%%%%%%%%%%%%%%%%%%%%%%%%%%%%%%%%%%%%%%%%%%%%%%%%%%%%%%%%%
%
% Description: calculate the objective "Total coordination cost
%

```

```
%%%%%%%%%%%%%%%%%%%%%%%%%%%%%%%%%%%%%%%%%%%%%%%%%%%%%%%%%%%%%%%%%%%%%%%%%
```

```
function [cost, data] = total_coord_cost(solution)
```

```
% input the DSM of process network
```

```
matrix=[0 0 0 0 0 0 0 0 0 0 0 0 0  
0.983 0 0 0 0 0 0 0 0 0 0 0 0  
0 0.983 0 0 0 0 0 0 0 0 0 0 0  
0 0 0.966 0 0 0 0 0 0 0 0 0 0  
0 0 0.923 0 0 0 0 0 0 0 0 0 0  
0 0 0.833 0 0 0 0 0 0 0 0 0 0  
0 0 0 0.966 0.923 0 0 0 0 0 0 0 0  
0.967 0 0 0 0 0 0 0 0 0 0 0 0  
0.968 0 0 0 0 0 0 0 0.967 0 0 0 0  
0 0 0 0 0 0 0 0 0 0.5 0 0 0  
0 0 0 0 0 0 0 0 0 0.5 0 0 0  
0 0 0.938 0 0 0.833 0.975 0 0.983 0 0.5 0];
```

```
extract_elements = [1 12];
```

```
% set system parameters to zero to remove their influence during clustering
```

```
for i = 1:length(extract_elements)  
    matrix(extract_elements(i),:) = 0;  
    matrix(:,extract_elements(i)) = 0;  
end
```

```
pow_c = 1;  
activity_in_cluster = []; % which activity in the cluster  
activity_out_cluster = [];  
no_of_cluster = 0; % number of cluster  
size_of_cluster = 0; % number of activity in a cluster  
temp = [];  
in_cluster_cost = 0;  
out_cluster_cost = 0;  
coord_cost = [];
```

```
% set cluster lable
```

```
cluster_lable = unique(solution);
```

```
% calculate total in_cluster_cost of activity i
```

```
for a = 1:length(cluster_lable)  
    activity_in_cluster = find(solution == cluster_lable(a));  
    size_of_cluster = length(activity_in_cluster);  
    for i = 1:size_of_cluster  
        for j = 1:size_of_cluster  
            in_cluster_cost = in_cluster_cost +  
(matrix(activity_in_cluster(i),activity_in_cluster(j)) +  
matrix(activity_in_cluster(j),activity_in_cluster(i))) *  
size_of_cluster^pow_c;  
        end  
    end
```

```
% calculate total out_cluster_cost of activity i
```

```
    activity_out_cluster = setdiff((1:length(matrix)),  
activity_in_cluster);  
    for k = 1:length(activity_out_cluster)  
        out_cluster_cost = out_cluster_cost +  
(matrix(activity_in_cluster(i),activity_out_cluster(k)) +  
matrix(activity_out_cluster(k),activity_in_cluster(i))) *  
length(matrix)^pow_c;
```

```

        end
        % calculate total coordination cost of activity i
        coord_cost(activity_in_cluster(i),1) = in_cluster_cost +
out_cluster_cost;
        in_cluster_cost = 0;
        out_cluster_cost = 0;
    end
end

% calculate total coordination cost of all activities in the DSM
cost=sum(coord_cost);
data=[];

return;

%%%%%%%%%%%%%%%%%%%%%%%%%%%%%%%%%%%%%%%%%%%%%%%%%%%%%%%%%%%%%%%%%%%%%%%%
%
% Description: apply Genetic Algorithm for activity clustering
%
%%%%%%%%%%%%%%%%%%%%%%%%%%%%%%%%%%%%%%%%%%%%%%%%%%%%%%%%%%%%%%%%%%%%%%%%

% set up the run-time environment
clear all
close all

diary off

% input the DSM of process network
matrix=[0 0 0 0 0 0 0 0 0 0 0 0
0.983 0 0 0 0 0 0 0 0 0 0 0
0 0.983 0 0 0 0 0 0 0 0 0 0
0 0 0.966 0 0 0 0 0 0 0 0 0
0 0 0.923 0 0 0 0 0 0 0 0 0
0 0 0.833 0 0 0 0 0 0 0 0 0
0 0 0 0.966 0.923 0 0 0 0 0 0 0
0.967 0 0 0 0 0 0 0 0 0 0 0
0.968 0 0 0 0 0 0 0 0.967 0 0 0
0 0 0 0 0 0 0 0 0.5 0 0 0
0 0 0 0 0 0 0 0 0 0.5 0 0
0 0 0.938 0 0 0.833 0.975 0 0.983 0 0.5 0];

% apply Genetic Algorithm
number_of_activities = size(matrix, 2);
[population,costhistory] = optimize_genetic_algorithm( ...
    @total_coord_cost,           ... % objective function
    number_of_activities,       ... % gene length
    number_of_activities,       ... % gene size
    100,                         ... % population size
    20,                          ... % min iteration
    1000,                        ... % max iteration
    5                             ... % epsilon
);

% output the results
for i = 1:size(population, 2)
    disp(sprintf('%d %d %d ', i, population(i).cost,
population(i).solution));
end

```

```

optima = population(1);
disp('Final Results:');
disp(sprintf('cost: %f', optima.cost));
cluster_flag = unique(optima.solution);
disp(sprintf('number of clusters: %d', length(cluster_flag)));

for f=1:length(cluster_flag)
    disp(sprintf('elements in cluster %d: ', f));
    [x y]=find(optima.solution==cluster_flag(f));
    disp(sprintf('activity%d ', y));
end

%%%%%%%%%%%%%%%%%%%%%%%%%%%%%%%%%%%%%%%%%%%%%%%%%%%%%%%%%%%%%%%%%%%%%%%%
%
% Description: re-sequence clusters to minimize "Total Feedback"
%
%%%%%%%%%%%%%%%%%%%%%%%%%%%%%%%%%%%%%%%%%%%%%%%%%%%%%%%%%%%%%%%%%%%%%%%%

function [y]=perms_partition(Com_New_DSM_matrix) % compress activities
in a cluster together and given the cluster index

% input the compressed DSM of service modules
Com_New_DSM_matrix=[1.889 0 1.889 0 0
0.975 0 1.771 0 0.983
0 0 1.816 0.983 0
0 0 0 0 0
0 0 0 1.935 1.967];

c = [];
v = perms(1:size(Com_New_DSM_matrix)); % per mutation
vrow = size(v,1);
for vs=1:vrow % column reposition
    a=zeros(size(Com_New_DSM_matrix));
    b=zeros(size(Com_New_DSM_matrix));
    tem=v(vs,:);
    for i=1:size(Com_New_DSM_matrix,1)
        a(:,i)=Com_New_DSM_matrix(:,tem(i));
    end
    for j=1:size(Com_New_DSM_matrix,1) % row reposition
        b(j,:)=a(tem(j),:);
    end
    bu=triu(b); % Extract upper triangular part of matrix
    nonzero=find(bu~=0); % Find non-zero elements
    count=size(nonzero,1); % Count how many non-zero elements
    depsum=zeros(1);
    for k=1:count
        depsum=depsum+bu(nonzero(k));
    end
    c(vs,:)=[depsum(1,:) count];
end

totalcost=[c(:,1).*c(:,2)];
y=[totalcost v]

%%%%%%%%%%%%%%%%%%%%%%%%%%%%%%%%%%%%%%%%%%%%%%%%%%%%%%%%%%%%%%%%%%%%%%%%

```

Appendix E –3³ Full Factorial Experimental Design

The application of DOE technique has been found in many disciplines and proved useful to improve process yields, reduce variability and reduce overall costs. The main purpose of using DOE in our study is to determine which factors are most influential on the response variable. For process modularization problem, *TCC* is the response variable. This study limits the factors to be the following three parameters. Table E.1 summarizes the factors and corresponding factor levels in DOE.

1) The Population Size: It defines how many individuals are in a population in a generation. In our experiments, the population size ranges from 20 to 100.

2) The Crossover Rate: It controls the application frequency of the crossover operator. Generally, the higher the crossover rate, the more quickly new structures are introduced into the population. Empirical studies show that the effective range of crossover rate is between 0.5 and 1.00 (Lin et al. 2003). The crossover rate in our experiments varied from 0.5 to 0.9 in increments of 0.2.

3) The Mutation Rate: It controls the probability of each gene to undergo a random change in the new population. Typical range of mutation rate is reported about 0.001 - 0.1 (Angelova and Pencheva 2011). The current experiments cover three of the mutation rate namely 0.01, 0.05 and 0.1.

Table E.1: Factors and levels

Factor	Type	Levels	Values		
Population Size	fixed	3	20	50	100
Crossover Rate	fixed	3	0.5	0.7	0.9
Mutation Rate	fixed	3	0.01	0.05	0.1

The effects of these variables were evaluated and analyzed in a 3³ full factorial experiments. The genetic algorithm was repeated 2 times for each probability on full combination of different levels of these three factors. *TCC* is tabulated in Table E.2.

Table E.2: *TCC* Changing according to factor levels

Population	Crossover Rate								
	0.5			0.7			0.9		
Size	Mutation Rate								
	0.01	0.05	0.1	0.01	0.05	0.1	0.01	0.05	0.1
20	104.130	98.496	83.302	100.996	85.434	89.544	142.804	116.276	144.144
	104.130	98.496	83.302	100.996	85.434	89.544	142.804	116.276	144.144
50	98.462	84.996	83.302	89.152	84.996	85.470	116.938	85.434	87.930
	98.462	84.996	83.302	89.152	84.996	85.470	116.938	85.434	87.930
100	98.462	84.996	83.302	89.152	84.996	85.470	116.938	85.434	87.930
	98.462	84.996	83.302	89.152	84.996	85.470	116.938	85.434	87.930

From the table, we observed that increase in Population Size from 20 to 50 significantly decreases *TCC*. However, there is no more change on *TCC* when further increasing the Population size to 100. We also found that the middle level of Crossover Rate seems to give lower *TCC* compared to the other two levels. However, the lowest *TCC* are always achieved by given Crossover Rate = 0.5 and Mutation Rate = 0.1. Thus, Crossover Rate = 0.5 and Mutation Rate = 0.1 are going to be used in the modularization algorithm for the case study. Based on experimental results, the analysis of variance (ANOVA) is calculated and displayed in Table E.3. In the table, we have excluded all higher order which involved 3 factors interactions as the effects are relatively small if compare with the main effects and 2 factors interactions. Those higher interactions are taken as the error for the experiment.

Table E.3: Analysis of Variance for *TCC*

Source of Variation	Degree of	Sum of	Mean Square	F ₀	P-Value
Crossover Rate	2	881.37	440.69	14.20	0.001
Mutation Rate	2	363.65	181.83	5.86	0.017
Population Size	3	4547.35	1515.78	48.83	0.000
Crossover Rate * Mutation Rate	4	233.58	58.39	1.88	0.179
Crossover Rate * Population Size	6	311.93	51.99	1.67	0.210
Mutation Rate * Population Size	6	1491.84	248.64	8.01	0.001
Error	12	372.48	31.04		
Total	35	8202.21			

Through observation, we found that Population Size with the lowest *p*-value = 0.000. This implies that there is significant evidence for a Population size effect on

TCC at 0.05 significance level. Although experimental results indicate no improvement on performance of GA with increasing in the Population Size, it is not clear which level of Population Size should be set in GA. The convergence of TCC over generation for varied Population Size at 20/50/100/150 is mapped out in Figure E.1. Solid lines in the figure represent the change of average TCC over generations. Dashed lines describe the trend of the best TCC over generations. Generally, the GA performs poorer with smaller Population Size. This is mainly because that the population provides an insufficient sample size. The best TCC converges the fastest when the Population Size is 100 (see the pink dashed line). On the other hand, increase of the Population Size to 150 results in a slow rate of convergence (see the green dashed line). This means that there is no need to have a large population size.

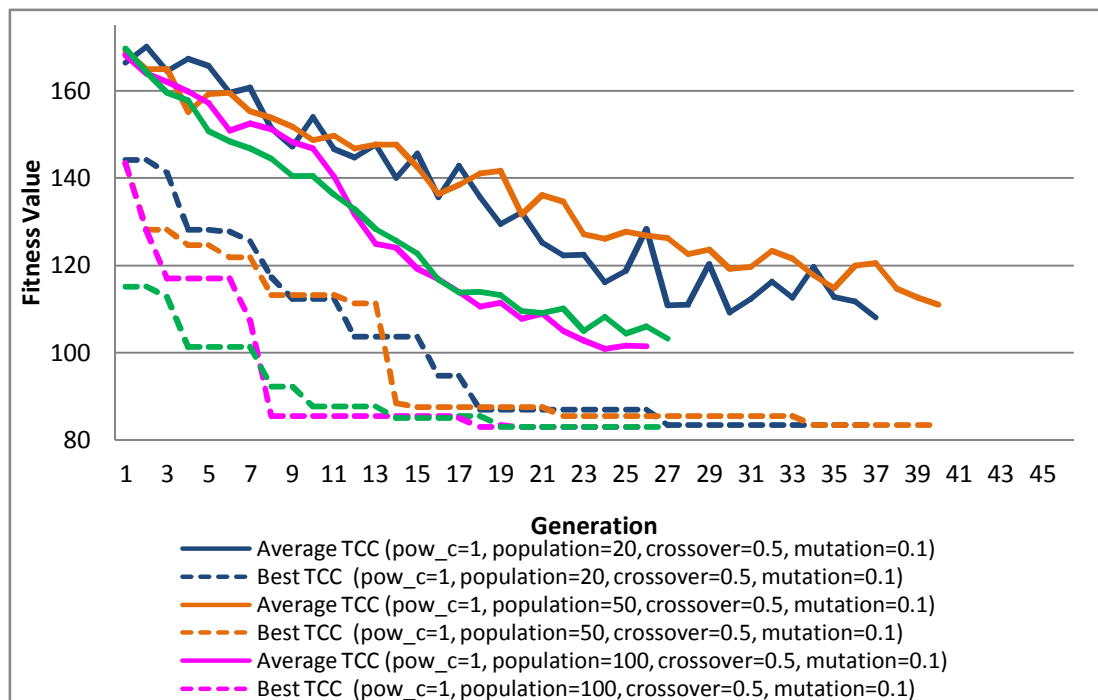

Figure E.1: Total coordination cost history with Population Size = 20/50/100/150

In summary, the values of the GA parameters are decided by applying the DOE technique. In particular, the Population Size = 100, the Crossover Rate = 0.5 and the Mutation Rate = 0.1.

Appendix F – Results of modularization

pow_c	Pop. Size	Cros. Rate	Mut. Rate	No. of Modules	TCC	Healthcare Services in Module								
						M1	M2	M3	M4	M5	M6	M7	M8	M9
1	20	0.5	0.01	6	104.13	3 5 6	12	8 9 10	4 7	1 2	11			
1	20	0.5	0.1	5	83.302	4 5 7	12	2 3 6	1	8 9 10 11				
1	20	0.5	0.5	5	85.438	12	3 4 5	2	8 9 10 11	1				
1	20	0.7	0.01	5	100.996	3 4 6	12	8 9 10 11	1 5 7	2				
1	20	0.7	0.1	5	89.544	1	6 12	3 4 5 7	8 9 10 11	2				
1	20	0.7	0.5	5	83.338	2 3 4 5 7	12	8 9 10 11	1	6				
1	20	0.9	0.01	9	142.804	5	11	12	3 4	8 9	1	6	2	7 10
1	20	0.9	0.1	7	144.144	1 6	5	7 8	12	3 4	2	9 10 11		
1	20	0.9	0.5	6	85.434	1	8 9	12	2 3 6	10 11	4 5 7			
1	50	0.5	0.01	7	98.462	8 9	1	4 5 7	2 3	6	10 11	12		
1	50	0.5	0.1	4	83.302	1 12	8 9	2 3 6	4 5 7					
1	50	0.5	0.5	5	84.996	8 9	2 3 4	1	12	10 11				
1	50	0.7	0.01	6	89.152	2 3 4 6	8 9	10 11	1	5 7	12			
1	50	0.7	0.1	5	85.47	1	2 3 4	10 11	8 9	6 12				
1	50	0.7	0.5	5	83.338	6	1	2 3 4 5 7	12	8 9 10 11				
1	50	0.9	0.01	6	116.938	4	1 11	5 7	8 9 10	2 3	6			
1	50	0.9	0.1	5	87.93	11	12	2 3 4 5 6 7	8 9 10	1				
1	50	0.9	0.5	6	85.434	8 9	10	12	4 5 7	1	2 3 6			
1	100	0.5	0.01	4	82.864	2 3 4 5 6 7	12	1	8 9 10 11					
1	100	0.5	0.1	4	82.864	8 9 10 11	12	1	2 3 4 5 6 7					
1	100	0.5	0.5	5	83.302	12	8 9	4 5 7	1	2 3 6				
1	100	0.7	0.01	5	96.33	12	1 6	4 5 7	8 9 10 11	2 3				
1	100	0.7	0.1	5	84.996	1	12	10 11	2 3 4 5 6 7	8 9				
1	100	0.7	0.5	5	83.302	8 9 10 11	4 5 7	12	1	2 3 6				
1	100	0.9	0.01	6	88.98	2 3 5 6	8 9	4 7	12	10 11	1			
1	100	0.9	0.1	5	83.302	12	4 5 7	1	2 3 6	8 9 10 11				
1	100	0.9	0.5	5	83.302	12	8 9	2 3 6	1	4 5 7				
1	150	0.5	0.01	4	82.864	2 3 4 5 6 7	12	1	8 9 10 11					
1	150	0.5	0.1	4	82.864	8 9 10 11	12	1	2 3 4 5 6 7					
1	150	0.5	0.5	4	82.864	8 9 10 11	12	1	2 3 4 5 6 7					
1	150	0.7	0.01	4	82.864	8 9 10 11	12	1	2 3 4 5 6 7					
1	150	0.7	0.1	4	82.864	2 3 4 5 6 7	12	1	8 9 10 11					
1	150	0.7	0.5	4	82.864	8 9 10 11	12	1	2 3 4 5 6 7					
1	150	0.9	0.01	4	82.864	2 3 4 5 6 7	12	1	8 9 10 11					
1	150	0.9	0.1	4	82.864	2 3 4 5 6 7	12	8 9 10 11	1					
1	150	0.9	0.5	4	82.864	8 9 10 11	12	1	2 3 4 5 6 7					

pow_c	Pop. Size	Cros. Rate	Mut. Rate	No. of Modules	TCC	Healthcare Services in Module								
						M1	M2	M3	M4	M5	M6	M7	M8	M9
2	20	0.5	0.01	4	558.504	2 3 4 5 6 7	8 9	1 12	10 11					
2	20	0.5	0.1	5	673.666	2 3 6	4 5 7	8 9 10 11	1	12				
2	20	0.5	0.5	5	633.69	6	8 9	10 11	1 12	2 3 4 5 7				
2	20	0.7	0.01	5	673.666	12	1	4 5 7	2 3 6	8 9 10 11				
2	20	0.7	0.1	3	465.712	2 3 4 5 6 7	8 9 10 11	1 12						
2	20	0.7	0.5	6	633.69	6	10 11	8 9	1	12	2 3 4 5 7			
2	20	0.9	0.01	5	558.504	12	2 3 4 5 6 7	8 9	10 11	1				
2	20	0.9	0.1	4	465.712	1	12	2 3 4 5 6 7	8 9 10 11					
2	20	0.9	0.5	4	540.898	6	2 3 4 5 7	8 9 10 11	1 12					
2	50	0.5	0.01	5	558.504	12	8 9	1	2 3 4 5 6 7	10 11				
2	50	0.5	0.05	4	465.712	12	1	8 9 10 11	2 3 4 5 6 7					
2	50	0.5	0.1	5	558.504	2 3 4 5 6 7	8 9	1	10 11	12				
2	50	0.5	0.5	5	558.504	12	1	2 3 4 5 6 7	10 11	8 9				
2	50	0.7	0.01	5	673.666	4 5 7	1	12	8 9 10 11	2 3 6				
2	50	0.7	0.05	4	558.504	8 9	2 3 4 5 6 7	10 11	1 12					
2	50	0.7	0.1	5	766.458	10 11	4 5 7	1 12	8 9	2 3 6				
2	50	0.7	0.5	4	465.712	12	8 9 10 11	2 3 4 5 6 7	1					
2	50	0.9	0.01	5	986.538	8 9	4 5 7	10 11 12	2 3	1 6				
2	50	0.9	0.05	5	558.504	8 9	1	12	2 3 4 5 6 7	10 11				
2	50	0.9	0.1	6	766.458	8 9	12	4 5 7	10 11	2 3 6	1			
2	50	0.9	0.5	4	465.712	2 3 4 5 6 7	8 9 10 11	1	12					
2	100	0.5	0.01	4	465.712	2 3 4 5 6 7	8 9 10 11	1	12					
2	100	0.5	0.1	4	465.712	2 3 4 5 6 7	8 9 10 11	1	12					
2	100	0.5	0.5	4	465.712	8 9 10 11	1	2 3 4 5 6 7	12					
2	100	0.7	0.01	5	558.504	10 11	2 3 4 5 6 7	1	8 9	12				
2	100	0.7	0.1	5	558.504	2 3 4 5 6 7	1	10 11	8 9	12				
2	100	0.7	0.5	4	465.712	12	8 9 10 11	2 3 4 5 6 7	1					
2	100	0.9	0.01	6	781.128	8 9 10	12	4 5 7	1	2 3 6	11			
2	100	0.9	0.1	5	558.504	2 3 4 5 6 7	10 11	12	8 9	1				
2	100	0.9	0.5	4	465.712	2 3 4 5 6 7	8 9 10 11	12	1					
2	150	0.5	0.01	4	465.712	2 3 4 5 6 7	8 9 10 11	12	1					
2	150	0.5	0.1	4	465.712	1	2 3 4 5 6 7	8 9 10 11	12					
2	150	0.5	0.5	4	465.712	2 3 4 5 6 7	8 9 10 11	12	1					
2	150	0.7	0.01	4	465.712	12	8 9 10 11	2 3 4 5 6 7	1					
2	150	0.7	0.1	4	465.712	2 3 4 5 6 7	8 9 10 11	12	1					
2	150	0.7	0.5	4	465.712	12	1	2 3 4 5 6 7	8 9 10 11					
2	150	0.9	0.01	4	465.712	12	8 9 10 11	2 3 4 5 6 7	1					
2	150	0.9	0.1	4	465.712	2 3 4 5 6 7	8 9 10 11	12	1					
2	150	0.9	0.5	4	465.712	12	1	2 3 4 5 6 7	8 9 10 11					

Appendix G – The code of bi-level GA-based scheduling algorithm

```

%%%%%%%%%%%%%%%%%%%%%%%%%%%%%%%%%%%%%%%%%%%%%%%%%%%%%%%%%%%%%%%%%%%%%%%%
%
% Description: the definition of the classes
%
%%%%%%%%%%%%%%%%%%%%%%%%%%%%%%%%%%%%%%%%%%%%%%%%%%%%%%%%%%%%%%%%%%%%%%%%

classdef Activity
    properties
        duration           % time cost for this activity
        resources          % resources need for performing this activity
        sub_activities     % sub activities that must do
        xor_sub_activities % xor sub activities
    end
end

classdef Application
    properties
        % global settings
        activities         % all activities in the process network
        resources          % all available resources at this point of time

        time_end          % where the time arrangement search ends
        cost_infinite     % the objective value for infeasible solutions
        one_pass_cost     % when pass one condition, decrease the cost
                        % by this value

        % run-time variable
        activity_sequence % the current activity sequence.
        % the second layer of searching needs to find a time arrangement based
        % on this sequence

        % patient preferences
        patient_pref_start_time % at when to start the first activity
        patient_pref_importance_coef % the patient's preference importance
    end
end

classdef Gene
    properties
        solution
        cost
        data
    end
end

%%%%%%%%%%%%%%%%%%%%%%%%%%%%%%%%%%%%%%%%%%%%%%%%%%%%%%%%%%%%%%%%%%%%%%%%
%
% Description: Genetic Algorithm, to minimize
%
%%%%%%%%%%%%%%%%%%%%%%%%%%%%%%%%%%%%%%%%%%%%%%%%%%%%%%%%%%%%%%%%%%%%%%%%

```

```

function y = optimize_genetic_algorithm(objective_function, gene_length,
gene_size, population_size, min_generation, max_generation, epsilon,
display_info)

% set default parameters if they are ignored
if nargin <= 2; gene_size      = 1;      end;
if nargin <= 3; population_size = 50;    end;
if nargin <= 4; min_generation = 30;    end;
if nargin <= 5; max_generation = 100;   end;
if nargin <= 6; epsilon      = 0.01;   end;
if nargin <= 7; display_info  = 1;      end;

% set random seed
helper_random_seed_stack('save', 89123);

% initialize population
y = [];
gene_cache = [];
for i = 1:population_size
    solution = floor(rand(1, gene_length) * (gene_size + 1));
    gene = calculate_gene_cost(objective_function, solution,
gene_cache);
    y = [y gene];

    if display_info == 1
        disp(sprintf('ga individual %d: %f %s', i, gene.cost,
helper_strcat_vector(gene.solution)));
    end
end
u = y;

% evolution
for generation = 1:(max_generation - 1)
    % sort solutions by costs
    for i = 1:size(y, 2)
        t = i;
        for j = (i + 1):size(y, 2)
            if y(j).cost < y(t).cost; t = j; end;
        end

        if t > i
            gene = y(i);
            y(i) = y(t);
            y(t) = gene;
        end
    end

    if display_info == 1 % output optima
        optima = y(1);
        disp(sprintf('cost: %f', optima.cost));
        disp(sprintf('solution: %s',
helper_strcat_vector(helper_remove_zeros(optima.solution))));
        disp(sprintf('data: %s', helper_strcat_vector(optima.data)));
    end
end

% converged?
if i > min_generation
    sum_cost = 0;
    for i = 1:size(y, 2)

```

```

        sum_cost = sum_cost + y(i).cost;
    end
    diff = abs(sum_cost / population_size - y(1).cost);
    if diff < epsilon; break; end;
end

% evolution
for i = 1:population_size
    trial = u(i).solution;

    r = i;
    while (r == i)
        for j = 1:population_size
            if rand < 0.1
                r = j;
                break;
            end
        end
    end

    crossover_gene = y(r);
    old_gene       = y(i);

    j_rand = floor(gene_length * rand) + 1;
    for j = 1:gene_length

        % crossover
        if (j == j_rand || rand < 0.5)
            trial(j) = crossover_gene.solution(j);
        else
            trial(j) = old_gene.solution(j);
        end

        % mutate
        if (rand < 0.1)
            old_block = trial(j);
            while old_block == trial(j)
                trial(j) = floor(rand * (gene_size + 1));
            end
        end
    end % end of mutation & recombination

    % evaluate the trial solution
    u(i) = calculate_gene_cost(objective_function, trial, gene_cache);

    if display_info == 1
        disp(sprintf('ga %d trial %d: %f %s', generation, i, u(i).cost,
helper_strcat_vector(trial)));
    end
end % end of calculation for trial vectors

% selection
successful_updates = 0;
for i = 1:population_size
    if u(i).cost <= y(i).cost
        y(i) = u(i);
        successful_updates = successful_updates + 1;
    end
end
end

```

```

        if display_info == 1
            disp(sprintf('one evolution cycle ended. successful updates: %d',
successful_updates));
        end
    end % end of the main iteration

    if display_info == 1
        disp('genetic algorithm finished calculation.');
```

```

    end

    helper_random_seed_stack('restore', 89123);

    return;

function y = calculate_gene_cost(objective_function, solution,
gene_cache)
    for i = 1:size(gene_cache, 2)
        if sum(gene_cache(i).solution - solution) == 0
            y = gene_cache(i);
            return;
        end
    end

    y = Gene;
    y.solution = solution;
    [y.cost, y.data] = objective_function(solution);

    gene_cache = [y gene_cache];
    if size(gene_cache, 2) > 3000
        gene_cache = gene_cache(1:3000);
    end

    return;

%%%%%%%%%%%%%%%%%%%%%%%%%%%%%%%%%%%%%%%%%%%%%%%%%%%%%%%%%%%%%%%%%%%%%%%%
%
% Description: function of helper in Genetic Algorithm
%
%%%%%%%%%%%%%%%%%%%%%%%%%%%%%%%%%%%%%%%%%%%%%%%%%%%%%%%%%%%%%%%%%%%%%%%%

function helper_random_seed_stack(method, random_seed)
    persistent history_seeds; if isempty(history_seeds); history_seeds =
[]; end;

    if strcmp(method, 'clear')
        while length(history_seeds) > 0; helper_random_seed_stack('restore',
1); end;
    end

    if nargin <= 1 || isempty(random_seed) || random_seed <= 0; return; end;

    if strcmp(method, 'init')
        helper_random_seed_stack('clear');
        helper_random_seed_stack('save', random_seed);
    end

    if strcmp(method, 'save')
```

```

    renv.rs = rand('state'); renv.ns = randn('state');
    history_seeds = [history_seeds, renv];
    rand('state', random_seed); randn('state', random_seed);
end

if strcmp(method, 'restore')
    hist_len = length(history_seeds);
    if hist_len == 0; return; end;
    renv = history_seeds(hist_len);
    rand('state', renv.rs); randn('state', renv.ns);
    history_seeds(hist_len) = [];
end

function y = helper_remove_zeros(x)
    y = [];
    for i = 1:size(x, 2)
        if x(i) > 0; y = [y x(i)]; end;
    end
    return;

function y = helper_strcat_vector(v, precision)
    if nargin <= 1; precision = 10; end;
    str_format = sprintf('%d', precision);
    str_format = ['%6' '.' str_format 'f'];
    ret = '';
    for i = 1:(size(v, 2) - 1)
        ret = [ret, sprintf(str_format, v(i)), ',', ' '];
    end
    if size(v, 2) > 0
        ret = [ret, sprintf(str_format, v(size(v, 2)))];
    end
    y = ret;

%%%%%%%%%%%%%%%%%%%%%%%%%%%%%%%%%%%%%%%%%%%%%%%%%%%%%%%%%%%%%%%%%%%%%%%%
%
% Description: the main program for healthcare activity optimization.
%
%%%%%%%%%%%%%%%%%%%%%%%%%%%%%%%%%%%%%%%%%%%%%%%%%%%%%%%%%%%%%%%%%%%%%%%%

% set up the run-time environment
clear all
close all
diary off

% input data
global app

app = Application;
app.cost_infinite           = 1e20;
app.one_pass_cost           = 1e10;
app.time_end                 = 61;
app.patient_pref_start_time = 20;
app.patient_pref_importance_coef = 1;

% resources set up
r1 = Resource; % Cardiologist: Dr Lim Su An/ Nurse: Naga
r1.schedules = [1 61 1];

r2 = Resource; % Senior Cardiologist: Prof Cullen/ Nurse: Verena

```

```

r2.schedules = [1 61 1];

r3 = Resource; % Radiology Technician: Fizah
r3.schedules = [1 61 1];

r4 = Resource; % Radiology Technician: Jamilah
r4.schedules = [1 61 1];

r5 = Resource; % Oculist: Dr Foo Fong Yee/ PSA: Idah
r5.schedules = [1 61 1];

r6 = Resource; % Senior Oculist: Dr James Ng/PSA: Ganga
r6.schedules = [1 61 1];

r7 = Resource; % Eye Testing Technician: PSA: Fara
r7.schedules = [1 61 1];

r8 = Resource; % Eye Testing Technician: PSA: Kavitha
r8.schedules = [1 61 1];

r9 = Resource; % Lasik OT: Chin Choi Lan
r9.schedules = [1 61 1];

r10 = Resource; % Ophthalmic Technician: Ruey
r10.schedules = [1 61 1];

r11 = Resource; % Reception Clerk PSA: Cecilia
r11.schedules = [1 61 1];

r12 = Resource; % Reception Clerk PSA: Mas
r12.schedules = [1 61 1];

r13 = Resource; % Payment Clerk: PSA: Jeya
r13.schedules = [1 61 1];

r14 = Resource; % Payment Clerk PAS: Priscilla
r14.schedules = [1 61 1];

app.resources = [r1 r2 r3 r4 r5 r6 r7 r8 r9 r10 r11 r12 r13 r14];

% build up the processing network by defining the modules
%
%           a1 (M4)
%
%           a2 (M3)   AND   a3 (M5)
%
%           a4 (M1)
%
%                   XOR
%                   a5 (M2)
%
%
a1 = Activity; % service module M4
a1.duration   = 1; % 6.16 minutes (1.23 time slot)
a1.resources  = [12]; % resource 11 and 12 interchangeable
a1.sub_activities = [2 3];
a1.xor_sub_activities = [];

a2 = Activity; % service module M3

```

```

a2.duration          = 6;           % 30.42 minutes (6.08 time slot)
a2.resources         = [5 7 9];     % [5/7] selected by the patient
                                   % can select [6/8]

a2.sub_activities   = [4];
a2.xor_sub_activities = [];

a3 = Activity;           % service module M5
a3.duration          = 3;           % 14.1 minutes (2.82 time slot)
a3.resources         = [1 3];     % [1] selected by the patient
                                   % can select [2]

a3.sub_activities   = [];
a3.xor_sub_activities = [5];

a4 = Activity;           % service module M1
a4.duration          = 9;           % 44.65 minutes (8.93 time slot)
a4.resources         = [5 7 10];  % [5/7] determined by previous
                                   % service module M3

a4.sub_activities   = [];
a4.xor_sub_activities = [5];

a5 = Activity;           % service module M2
a5.duration          = 3;           % 12.48 minutes (2.50 time slot)
a5.resources         = [13];      % resource 13 and 14 interchangeable
a5.sub_activities   = [];
a5.xor_sub_activities = [];

```

```
app.activities = [a1 a2 a3 a4 a5];
```

```

% run the main procedure
number_of_activities = size(app.activities, 2);
population = optimize_genetic_algorithm( ...
    @activity_sequence_cost,           ... % objective function
    number_of_activities,              ... % gene length
    number_of_activities,              ... % gene size
    500,                               ... % population size
    5,                                  ... % min iteration
    40,                                 ... % max iteration
    5                                   ... % epsilon
);

```

```

% output the results
for i = 1:size(population, 2)
    disp(sprintf('individual %d: %f %s', i, population(i).cost,
helper_strcat_vector(helper_remove_zeros(population(i).solution),
0)));
end

```

```

optima = population(1);
disp('Final Results:');
disp(sprintf('cost: %f', optima.cost));
disp(sprintf('activity sequence: %s',
helper_strcat_vector(helper_remove_zeros(optima.solution), 0)));
disp(sprintf('time arrangement: %s', helper_strcat_vector(optima.data,
0)));
%%%%%%%%%%%%%%%%%%%%%%%%%%%%%%%%%%%%%%%%%%%%%%%%%%%%%%%%%%%%%%%%%%%%%%%%%%
%
% Description: objective function of the sequence
%

```

```
%%%%%%%%%%%%%%%%%%%%%%%%%%%%%%%%%%%%%%%%%%%%%%%%%%%%%%%%%%%%%%%%%%%%%%%%%
```

```
function [cost, time_arrangement] = activity_sequence_cost(x)
    global app

    % default return values
    cost = app.cost_infinite;
    time_arrangement = [];

    % remove all zeros
    sequence = helper_remove_zeros(x);

    % apply other network rules
    cost = processing_network_test(sequence);
    if cost > 0; return; end;

    % search for a possible time arrangement
    % here's the second layer of search
    app.activity_sequence = sequence;
    population = optimize_genetic_algorithm( ...
        @time_arrangement_cost,           ... % objective function
        size(sequence, 2),                 ... % gene length
        app.time_end,                       ... % gene size
        size(sequence, 2) * 100,           ... % population size
        5,                                   ... % min iteration
        50,                                  ... % max iteration
        5,                                   ... % epsilon
        0,                                   ... % debug info
    );

    % return
    cost = population(1).cost;
    time_arrangement = population(1).solution;

    return;
```

```
%%%%%%%%%%%%%%%%%%%%%%%%%%%%%%%%%%%%%%%%%%%%%%%%%%%%%%%%%%%%%%%%%%%%%%%%%
```

```
%
% Description: to check if the activity sequence is feasible according
% to the process network
%
```

```
%%%%%%%%%%%%%%%%%%%%%%%%%%%%%%%%%%%%%%%%%%%%%%%%%%%%%%%%%%%%%%%%%%%%%%%%%
```

```
function y = processing_network_test(sequence)
    global app

    y = app.cost_infinite; % default value, not compatible

    % the first activity must be the first activity to be scheduled
    if size(sequence, 2) == 0 || sequence(1) > 1; return; end;
    y = y - app.one_pass_cost;

    % each activity to be scheduled once
    for i = 1:size(sequence, 2)
        for j = (i + 1):size(sequence, 2)
            if sequence(i) == sequence(j); return; end;
        end
    end
end
```

```

y = y - app.one_pass_cost;

% if an activity is in the sequence, then one of its parents must be in
% the sequence and prior to this activity
% except activity number one
for a1_location = 2:size(sequence, 2)
    a1 = sequence(a1_location);
    found_a_valid_parent = 0;
    for i = 1:size(app.activities, 2)
        parent_location = element_location(sequence, i);
        if parent_location <= 0; continue; end;

        children = [app.activities(i).sub_activities
app.activities(i).xor_sub_activities];
        if element_location(children, a1) > 0 && parent_location <
a1_location
            found_a_valid_parent = 1;
            break;
        end
    end

    if found_a_valid_parent == 0; return; end;
end
y = y - app.one_pass_cost;

% checking for every activity
for a1 = 1:size(app.activities, 2)
    a1_location = element_location(sequence, a1);
    if a1_location <= 0; continue; end;

    % handle AND relationships
    sub_activities = app.activities(a1).sub_activities;
    for i = 1:size(sub_activities, 2)
        a2 = sub_activities(i);
        a2_location = element_location(sequence, a2);
        if a2_location < a1_location; return; end;
    end
    y = y - app.one_pass_cost;

    % handle XOR relationships
    xor_activities = app.activities(a1).xor_sub_activities;
    selected_xor_activity = 0;
    for i = 1:size(xor_activities, 2)
        a2 = xor_activities(i);
        a2_location = element_location(sequence, a2);
        if a2_location <= 0; continue; end;

        if a2_location < a1_location; return; end;
        if selected_xor_activity > 0; return; end;

        selected_xor_activity = a2;
    end
    if size(xor_activities, 2) > 0 && selected_xor_activity == 0; return;
end;
y = y - app.one_pass_cost;
end

y = 0; % pass all the tests, return compatible
return;

```

```

function y = element_location(x, a)
    y = 0;

    for k = 1:size(x, 2)
        if x(k) == a
            y = k;
            return;
        end
    end

    return;

%%%%%%%%%%%%%%%%%%%%%%%%%%%%%%%%%%%%%%%%%%%%%%%%%%%%%%%%%%%%%%%%%%%%%%%%
%
% Description: objective function of time arrangement
%
%%%%%%%%%%%%%%%%%%%%%%%%%%%%%%%%%%%%%%%%%%%%%%%%%%%%%%%%%%%%%%%%%%%%%%%%

function [cost, data] = time_arrangement_cost(t)
    global app

    cost = app.cost_infinite; % default a large value
    data = [];

    % dimensions must match
    if size(t, 2) ~= size(app.activity_sequence, 2); return; end;

    % get the current activity sequence
    s = [];
    for i = 1:size(app.activity_sequence, 2)
        s = [s app.activities(app.activity_sequence(i))];
    end

    % in asc order && no overlaps
    abs(t(1)) >= app.patient_pref_start_time;
    for i = 2:size(t, 2)
        if t(i - 1) + s(i - 1).duration > t(i); return; end;
        cost = cost - app.one_pass_cost; % pass one test, decrease the cost
    end

    % check resource availability
    for i = 1:size(s, 2)
        a = s(i);
        activity_from_time = t(i);
        activity_to_time = t(i) + a.duration;

        for j = 1:size(a.resources, 2)
            r = app.resources(a.resources(j));
            for k = 1:size(r.schedules, 1)
                schedule = r.schedules(k,:);
                resource_from_time = schedule(1);
                resource_to_time = schedule(2);
                available = schedule(3);

                if activity_from_time >= resource_from_time && activity_from_time
<= resource_to_time && available == 0; return; end;

```

```

        if activity_to_time >= resource_from_time && activity_to_time <=
resource_to_time && available == 0; return; end;

        if activity_from_time >= resource_from_time && activity_to_time
<= resource_to_time && available == 1; break; end;
        end

        % activity a can take resource r
        cost = cost - app.one_pass_cost;
        end
        end

        % passed all the tests, calculate the real cost
        % cost one: makespan from the start of activity one to when
        % the last activity ends
        cost = t(size(t, 2)) + s(size(s, 2)).duration - t(1);

        % cost two: if the start time is not the patient's preference time, then
        % add the distance as a cost
        cost = cost + (abs(t(1) - app.patient_pref_start_time) *
app.patient_pref_importance_coef);

        return;

%%%%%%%%%%%%%%%%%%%%%%%%%%%%%%%%%%%%%%%%%%%%%%%%%%%%%%%%%%%%%%%%%%%%%%%%

```

Appendix H –2⁴ Factorial Experiment

A 2⁴ factorial experiment on the key parameters in the algorithm is conducted. We decide to implement 2⁴ experiment because 2^k experiment can substantially reduce the total number of runs and it is especially useful to the screening experiments in the early stage when we are not certain which factor may have significant effect on the response. The choice of factors and levels are listed in Table H.1.

Table H.1: Factors and levels

Factor No.	Factor	Type	Levels	Values	
				-	+
A	Population Size_1 st Layer	fixed	2	100	500
B	Population Size_2 nd Layer	fixed	2	100	500
C	Mutation Rate	fixed	2	0.05	0.1
D	Crossover Rate	fixed	2	0.5	0.9

The response variable in the experiment is the *RC* which is the outcome the bi-level scheduling algorithm. The *RC* calculates the sum of a patient's makespan and the difference between the starting time slot with the preferred time slot. The outcome of each experiment is given in the Appendix E. The ANOVA table is given in Table H.2.

The ANOVA gives a summary of the main effects and interactions. The *p*-values for main factors A, B, C and interactions A*B, A*C, B*C, A*B*C are significant at alpha = 0.05 significance level. Therefore, the values of factors A, B and C are set at “+” while the factor D is set at “-” in order to minimize the frequency to apply crossover operator. In summary, the values of the GA parameters are decided by applying the DOE technique. In particular, the Population Size_1st Layer = 500, Population Size_2nd Layer = 500, Mutation Rate = 0.1 and Crossover Rate = 0.5.

Table H.2: ANOVA table of 2⁴ DOE

Source of Variation	Degree of Freedom	Sum of Squares	Mean Square	F ₀	P-Value
Main Effects					
A	1	390657152	390657152	8729768.76	0.000
B	1	391678066	391678066	8752582.48	0.000
C	1	391342276	391342276	8745078.8	0.000
D	1	1275	1275	28.49	0.001
2-Way Interactions					
A*B	1	391090528	391090528	8739453.14	0.000
A*C	1	390866820	390866820	8734454.08	0.000
A*D	1	153	153	3.42	0.083
B*C	1	390713058	390713058	8731018.06	0.000
B*D	1	32	32	0.72	0.410
C*D	1	5	5	0.1	0.755
3-Way Interactions					
A*B*C	1	390936722	390936722	8736016.13	0.000
A*B*D	1	12	12	0.28	0.604
A*C*D	1	200	200	4.47	0.051
B*C*D	1	36	36	0.81	0.382
4-Way Interactions					
A*B*C*D	1	10	10	0.23	0.641
Error	16	716	45		
Total	31	2737287062			