

Demand Side Load Management of Smart Grids Using Intelligent Trading/Metering/ Billing System

***^aP. Wang, Member, IEEE, ^aJ. Y. Huang, ^aY. Ding, ^aP. Loh, Member, IEEE and
^aL. Goel, Member, IEEE,***

*^aEEE School, Nanyang Technological University, Singapore 639798, (e-mail:
epwang@ntu.edu.sg)*

Abstract

Conventional power systems have been experiencing transition from centralized supply side management to decentralized supply&demand side management due to power system restructuring and addition of distributed generations (DGs) and Smart Grids (SGs) or Smart Distribution Systems (SDSs) with renewable power sources in the past two decades. Therefore load management under the new operating environment becomes more difficult than that under the conventional environment. This paper presents an Intelligent Metering/Trading/Billing System (ITMBS) and its implementation in Demand Side Load Management (DSLMM) of SGs and SDSs. The ITMBS provides real time price information to customers through communication networks. Customers can adjust their demands through setting the operating time of some of the home appliances with energy storage feature such as heaters based on the real time prices to shift their consumptions and save cost. Customers can also participate in Direct Load Control (DLC) program in control center of a micro grid to shift their air condition demands through changing on and off circle based on the real time prices and weather conditions to save energy and to shift system peak load.

Index Terms

Power market, demand side load management, direct load control, smart grid, intelligent metering, smart meter, time of use metering, two way metering, peak load shedding

I. INTRODUCTION

Significant changes are taking place in power industries around the world. The first is power system restructuring and introduction of the power market in system operation. The second is high penetration of renewable power in conventional power systems where fossil energy is in a dominating position. The objectives of restructuring are to economically separate a vertically integrated monolithic utility into many small generation companies (Gencos), transmission companies (Transcos) and distribution companies (Discos), and to introduce competitive power market where those companies and customers can sell and buy electricity to reduce electricity cost [1]-[5]. In order to induce efficient use of transmission and generation resources by providing correct economic signals, the spot price was introduced for deregulated power systems [1]. In spot market, electricity prices are different from time to time. In such a market, consumers getting exposed to a volatile electricity prices may modify their demand profile through

mitigating their electricity consumption from one time slot to another to reduce their electricity bills. Change of customer's consumption pattern, on the other hand, may reduce the electricity price spikes. A review of the aggregate offers made by suppliers confirms that even a modest increase in demand elasticity could dramatically reduce the extremes in price volatility. Therefore there is a strong need to increase customer participation in markets to enhance system reliability and reduce price volatility [2]. Demand responses to spot prices have been considered as a measurement of demand side load management to shift peak loads and to reduce system spinning reserve.

Direct control of air conditioning loads (ACL) is a common load management program to shelve peak loads to increase system reliability and to reduce the system operating cost. An effective optimization method for load scheduling was developed based on an analytical model, which allowed any length of the control period and any cycle rates [5]. The effect of direct control of ACL on generation system reliability was studied using the Monte Carlo simulation methodology [6]. An effective optimization method for scheduling ACL in the commercial buildings was presented to minimize the load reduction so as to reduce the effect of customers' discomfort and to maintain company income [7]. A fuzzy load model for direct control of appliances was first developed and a methodology for optimizing both customer satisfaction and utility unit commitment savings was presented based on this fuzzy DLC load model [9]. Electrical models of heating, ventilation and air conditioning residential loads were proposed and were implemented and tested to assess their accuracy and suitability in specific kinds of applications [8]. Most of those developed techniques focused on development of direct load control models and their impact on load curves. Most of the existing implementations are for industry and commercial customers with special control equipment. The direct control of residential loads was rarely considered because of lack of control equipment.

There is a growing interest around the world in smart grid technologies such as smart metering and smart control from power industry due to the changes in power system structure and operation, and additions of small green power producers. In 2009, The Energy Market Authority (EMA) of Singapore has launched a pilot project for an "Intelligent Energy System" (IES). The project will test a range of smart grid technologies to enhance the capabilities of Singapore's power grid infrastructure. In 2008, Science & Engineering Research Council of Singapore investigated S\$38 millions initializing its first energy center. Total of S\$7 millions have been awarded to 10 projects on intelligent energy distribution systems. The smart metering/trading/billing system is one of those projects. In this project, Time-of-Use (ToU) metering has been implemented to incorporate real time price in charging customers based on real time electricity consumption. Two way meters have been developed to record the electricity consumed and sold to power grid for small family renewable power producers. To save the tremendous labor cost in meter reading and billing process, many automated meter reading (AMR) systems and advanced digital meters have been studied and developed in different counties [11-16]. The AMR systems can read data without physical access to meters. Advanced communication technologies such as power line communication, wireless communication and optical communication network also make metering system much smarter ever with two way communication function. The advanced intelligent metering systems provide basic platforms for the implementation of direct control of residential load in distribution systems.

This paper presents an intelligent trading/metering/ billing system (ITMBS) developed in Nanyang Technological University of Singapore and its implementation in Demand Side Load Management (DSLMM) of smart grids (SGs) and smart distribution systems (SDSs). The ITMBS provides real time price information to customers through two way communication network. Customers can adjust their demands through setting the operating time of the home appliances with energy storage feature such as water heaters based on real time price to shift their consumptions and save costs. Customers can also participate in direct load control program in control center of a micro grid to shift their air condition demands through changing on and off circle based on the real time prices and weather conditions to save energy and to shift system peak load.

II. SYSTEM INTRODUCTION AND FUNCTIONS

A. System configuration

The proposed system is initially developed for facilitating trading, metering and billing operation among customers, power market, generation companies, retailers and small independent family power producers in future smart grids. The illustrative diagram of the system is shown in Fig. 1. The system consists of smart meters, communication networks, database and management system, website and display and control units (DCUs). General operation of the proposed system includes several steps. First, the water, gas, and electric consumption data are measured by smart meters. ZigBee and power line communication (PLC) networks are used to transfer data from meters to local servers. The DCU provides real time information regarding market price and promotion plans. Central and local databases store all the consumption data and customer information. The central system will manage all the transactions and customer information.

B. Smart Meters

Smart gas, water and electricity meters are basic components in the system. Most gas, water and energy meters currently installed in Singapore are mechanical meters and digital meters. The sensors embedded in those meters are the T-probe for water meter, pulse emitter for gas and power measurement integrated circuit for electricity. Three meters are integrated by a display and control unit designed for three meters. The meters are only used as the sensors to collect data for DCUs. The developed DCU is shown in Fig. 2.

The functions of the DCU include:

- a. Collect real time consumption data from three meters. Electricity consumptions are stored in the DCU in slot of 30 minutes to implement time-of-use function to incorporate the real time prices from the power market.
- b. Two way metering function of electricity meters are also implemented by the DCU to record electricity sold to power market by a small family power producer who has installed renewable power conversion system such as PV or light wind turbine generator on rooftop or backyard.
- c. One of the major problems for the smart grid system is the illegal tapping of gas, water, and electricity. Threshold detection is added in the DCU. The average usage for the latest several months, which can be obtained from the consumption history, is used to detect electricity thief through comparison between the usage and the threshold. Normally, the

average usage is stable. If the usage for the previous month is much lower than the threshold, the proposed system will remind the energy supply company to arrange staff to check wrong doing.

- d. The DCU can display the daily, monthly and yearly gas, water and electricity consumptions and daily usage pattern, and can provide real time market price curve. It can also control and set the operating time period of home appliances.
- e. For the smart control of home equipment, a programmable timer graphic user interface (GUI) as shown in Fig. 3 has been developed and will be imbedded into the DCU for customers to select operating periods of home equipment. Using the GUI, users can easily set timer to switch on/off the appliances based on real time prices according to their requirement. Customers can also remotely turn off their home equipment at their working places or oversea to save energy.
- f. The system has flexibility for adding more functions according to the different requirements.

C. Communication networks

Communication networks used for the metering system include ZigBee wireless communication and power line communication and internet networks. The ZigBee is mainly used for the applications which require a low data rate and long battery life. The PLC is a technology to transfer data signals through the existing power transmission and distribution network. Compared with other wire communication technologies, the PLC requires no extra charge for building network. The only requirement is to find a wall outlet in a given building and plug in the power line modem. Both of ZigBee and PLC are used to transfer data from meters to the coordinator. The main advantages of ZigBee and PLC are easy access and low cost of installation. In addition, dual communication networks can reduce the data error rate and increase the reliability of data transmission. Data is transferred from meters to the DCUs which are also nodes of communication network. The coordinators collect the data from hundreds of meters and send the data to the local database through the universal asynchronous receiver/transmitter (UART) interface. Considering cost, the system utilizes the internet to transfer data from the local database to the center database. The communication protocol developed based on the proposed communication networks is the embedded common information protocol which can be easily connected to any communication networks such as Zigbee and PLC and is embedded in microcontroller of the circuit board.

D. Database and management system

Customer information is stored in both local and center database. The database structure is shown in Fig. 4. Local database stores data from one or several nearby buildings. All of the data from the local database can be exchanged between center database and any local database. Information stored in the database include:

Customer data: customer name, address, customer ID, purchase and payment plans, real time energy consumption for each time slot, and balance etc.

Company data: supplier name, address, company ID and promotion plans, etc.

Management software will collect data from all meters, calculate balance for each customer, send bill etc. Management software will also schedule the air conditional load and provide market information to customers.

E. Website

New power market needs to offer multiple rates and plans to meet different requirements from customers. The ITMBS online provides a web portal for customers to buy electricity (may be gas and water) from different companies through different plans. These plans include bilateral purchase contracts with different generation companies. Customer can also buy from spot power market based on real time market prices and pay bill based on time of use. Current system calculates electricity bill for residential customers using fixed peak and non peak hour prices in Singapore. One project from electric market authority of Singapore is testing the possibility to implement time of use pricing and bilateral contract schemes for small customers using intelligent metering system. The proposed system also provides pre and after pay schemes to make the system more flexible. If users select the prepay plan, they should pay for the energy in advance. For prepaid customers, the price may be cheaper than the postpaid. However the system will send the warning signal to the customers from DCU if the money left in their account is close to zero. If a customer failed to top up, the system may stop its electricity supply shortly. Different energy supply companies can provide their bilateral contract plans and promotions in the web.

Past transactions and consumption history can also be seen from the web portal. With the time of use function, the statistic usage pattern can be computed and provided to customers by the web portal. Compared with the existing system, the proposed system can provide the more detail and complete consumption history to the users. Fig.5 shows the website of the ITMBS. Although the website can display all the information, the DCU also provide users quick and easy access to most information of the system.

III. IMPLEMENTATION OF DIRECT LOAD CONTROL

Most unique function of the proposed metering/trading/billing system is its embedded demand side load management using the DCU. Two load management schemes are implemented in the system to allow customers to participate demand side load management in low voltage distribution systems. One is the time setting function embedded in the DCU for customer to set the operating time of home appliances with energy storage function such as water heaters. A customer can select the operating time based on updated price curves which are provided by the system through the website or the DCU. The second scheme is to allow customers to participate the direct load control program provided by control center in a smart distribution system. System operator can use the ITMBS to schedule air conditioning loads to shave peak loads.

A. Direct load shift from customers

In the first scheme, customers directly and voluntarily participate in price incentive load shift. Daily price curve for 48 time slots based on the real time price history can be obtained using the statistic method embedded into the system. The average price curve can be based on data from one, two or many months to allow customer to find price pattern. A typical price curve from Singapore power market is shown in Fig. 6. Customers can set the operating times of those appliances to the slots with the lowest prices. For example, if customer can heat water between

4am to 7am the cost will be reduced by half from almost 240 to 120(\$/MWh).

On the other hand, the simple load shift done by customers can make significant contribution to system reserve management. A typical demand curve of Singapore power grid for a particular day is shown in Fig. 7. The highest demand is 4826 MW and the lowest demand is 3972MW. The highest demands are from 19:30pm to 22:00pm during which people usually take bath during this period. The lowest demand period is from 4:00am to 8:00am. Assuming that 10 percent of 1 million families in Singapore have installed 2 kW water heaters with the thermal insulated water tanks, the maximum demand from those heaters will be 200MW without considering coincident factor. If the average time to heat water is 30 minutes and the demand is evenly distributed in the peak period of 150 minutes after considering coincident factor, the average demand will be 40MW for the period. If 100 percent of those customers can shift water heating time from the peak period to off peak period using the time function in the ITMBS, the power system operating reserve will be reduced by 40 MW. This is extremely significant saving for a power system with high renewable power penetration.

B. Direct control of air conditioning load

Direct control of air conditioning load for residential customers becomes possible with the implementation of the ITMBS. The corresponding automatic switch has to be installed for each direct load control customer and controlled by the DCU. In this test system, random process produced in the central server will be used to sequentially and proportionally turn on and off ACLs during peak period. The on/off schedule of all ACLs can be determined using the existing optimization techniques [5]-[9]. For example, on/off times of air condition loads for residential customers can be determined by system operators based on the customer willingness to participate the program in terms of the compensation [17]. Customers are allowed to submit their interruption costs for the peak period 10, 20 or 30 minutes. These data will be sent to system server for system operator to schedule the cycling on/off times and duration. The objective of dispatching off times and durations of ACLs and spinning reserve is to minimize total system cost which includes the system energy cost, the system spinning reserve cost and the compensation cost to the ACL customers. It should be noted that all existing techniques can be embedded in the system to schedule the ACLs.

IV. CONCLUSIONS

This paper presents an intelligent metering/trading/billing system (ITMBS) and its implementation in demand side load management of SGs and SDSs. The DCU of the metering system provides display and control functions to check real time market prices and to remotely switch on/off home appliances. The functions make it possible to allow small residential customers to participate in demand side load management. Customers can adjust their demands through setting the operating time of some of the home equipment with energy storage future such as heaters based on real time price to shift their consumptions and save cost. This will automatically reduce system peak load and prices spikes. Customers can also participate in system direct load control program through the agreement with the control center of a micro grid to shift their air condition demands through changing on and off cycle based on the real time prices and weather conditions to save energy and to shift system peak load.

Acknowledgements

This ITMBS project is financially sponsored by the Intelligent Energy Distribution Systems Thematic Research Grant from A*STAR Science & Engineering Research Council, Singapore.

V. REFERENCES

- [1] F. C. Schweppe, M. C. Caramanis, R. D. Tabors, and R. E. Bohn, *Spot Pricing of Electricity*, Boston, MA: Kluwer, 1988.
- [2] J. D. Kueck, B. J. Kirby, J. Eto, R. H. Staunton, C. Marnay, C. A. Martines, C. Goldman: "Load As a Reliability Resource in Restructured Electricity Markets," ORNL/TM2001/97, LBNL-47983, June 2001.
- [3] K. Bhattacharya, M. H. J. Bollen and J. E. Daalder, *Operation of Restructured Power Systems*, Boston, Kluwer Academic Publishers, 2001.
- [4] M. Shahidehpour and M. Alomoush, *Restructured Electrical Power Systems: Operation, Trading and Volatility*, Marcel Dekker Inc., 2001.
- [5] F. I. Denny and D. E. Dismukes, *Power System Operations and Electricity Markets*, Boca Raton, CRC Press, 2002.
- [6] A. I. Cohen, "An Optimization Method for Load Management Scheduling", *IEEE Transactions on Power Systems*, Vol. 3, No. 2, pp. 612-618, May, 1988.
- [7] H. Salehfar and A. D. Patton, "Modeling and Evaluation of the System Reliability Effects of Direct Load Control", *IEEE Transactions on Power Systems*, Vol. 4, No. 3, pp. 1024-1030, August 1989.
- [8] J. Chen, F. N. Lee, A. M. Breipohl and R. Adapa, "Scheduling Direct Load Control to Minimize System Operational Cost", *IEEE Transactions on Power Systems*, Vol. 10, No. 4, pp. 1994-2001, November 1995.
- [9] K. Bhattacharyya and M. L. Crow, "A Fuzzy Logic Based Approach to Direct Load Control", *IEEE Transactions on Power Systems*, Vol. 11, No. 2, pp. 708-714, May 1996.
- [10] A. Molina, A. Gabaldon, J. A. Fuentes and C. Alvarez, "Implementation and Assessment of Physically based Electrical Load Models: Application to Direct Load Control Residential Programs", *IEE Proc.-Gener. Transm. Distrib.*, Vol. 150, No. 1, pp. 61-67, Jan. 2003.
- [11] H. Tram, "AMI Benefits in T&D – What Is for Real?," *Distribu TECH Conference*, 2007.
- [12] I. Steklac and H. Tram, "Advanced AMR Benefits – Utility Case Studies," *Electric Light & Power*, July/August 2005.
- [13] I. Steklac and H. Tram, "Enterprise Benefits of AMR," *Hart's Energy Market*, November 2004.
- [14] S. Rogai, "Telegestore Project Progresses and Results (Keynote)," in *IEEE Int. Symp. on Power Line Communications and Its Applications (ISPLC-2007)* Pisa, Italy, p. 1, 2007.
- [15] Energy watch, "Get Smart: Bringing meters into the 21st century," Aug. 2005, p. 16.
- [16] G. Deconinck, "An evaluation of two-way communication means for advanced metering in Flanders (Belgium)," *IEEE International instrumentation and Measurement Technology Conference Victoria*, Vancouver Island, Canada, May 12-15, 2008.
- [17] Q. Wu, P. Wang, and L. Goel, "Direct Load Control Considering Interrupted Energy Assessment Rate in Restructured Power Systems", *Proceeding of IEEE Power Engineering Society, General Meeting*, July 26-30, Calgary, Alberta, Canada, 2009

VI. BIOGRAPHY

Peng Wang (M'00) received his B.Sc. degree from Xian Jiaotong University, China, in 1978, the M. Sc. degree from Taiyuan University of Technology, China, in 1987, and the M. Sc. and Ph.D. degrees from the University of Saskatchewan, Canada, in 1995 and 1998, respectively. Currently, he is an associate professor at Nanyang Technological University, Singapore.

Jiyan Huang received the B.Eng (Hons.), M.Eng., and Ph.D. degrees from University of Electronic Science and Technology of China, Chengdu, China, in 2003, 2005, and 2008, respectively. Currently, he is a Research Fellow at the School of Electrical and Electronic Engineering, Nanyang Technological University, Singapore.

Yi Ding received his B.Eng from Shanghai Jiaotong University, China, and Ph.D. from Nanyang Technological University, Singapore, respectively. Currently he is a research fellow in Nanyang Technological University, Singapore. His research interests focus on reliability & availability evaluation and optimal design, power systems operation and power market.

Poh Chiang Loh (S'01-M'04) received his B.Eng (Hons) and M.Eng from the National University of Singapore in 1998 and 2000 respectively, and his Ph.D from Monash University, Australia, in 2002, all in electrical engineering. During the summer of 2001, he was a visiting scholar with the Wisconsin Electric Machine and Power Electronics Consortium, University of Wisconsin-Madison, USA, where he worked on multilevel inverters. From 2002 to 2003, he was a project engineer with the Defence Science and Technology Agency, Singapore, managing major defence infrastructure projects and exploring new technology for defence applications. Since 2003, he is an assistant professor with the Nanyang Technological University, Singapore.

Lalit Goel was born in New Delhi, India, in 1960. He obtained his BTech Degree in electrical engineering from the Regional Engineering College, Warangal, India in 1983, and his MSc and PhD degrees in electrical engineering from the University of Saskatchewan, Canada, in 1988 and 1991 respectively. He joined the School of EEE at the Nanyang Technological University (NTU), Singapore, in 1991 where he is presently a professor.

List of Figures

- | | |
|----------|---|
| Figure 1 | Intelligent Trading/Metering/Billing System |
| Figure 2 | Display and control unit |
| Figure 3 | GUI of display and control unit |
| Figure 4 | Database structure |
| Figure 5 | Web portals of the ITMBS |
| Figure 6 | Price curve for a typical day |
| Figure 7 | Demand curve for a typical day |

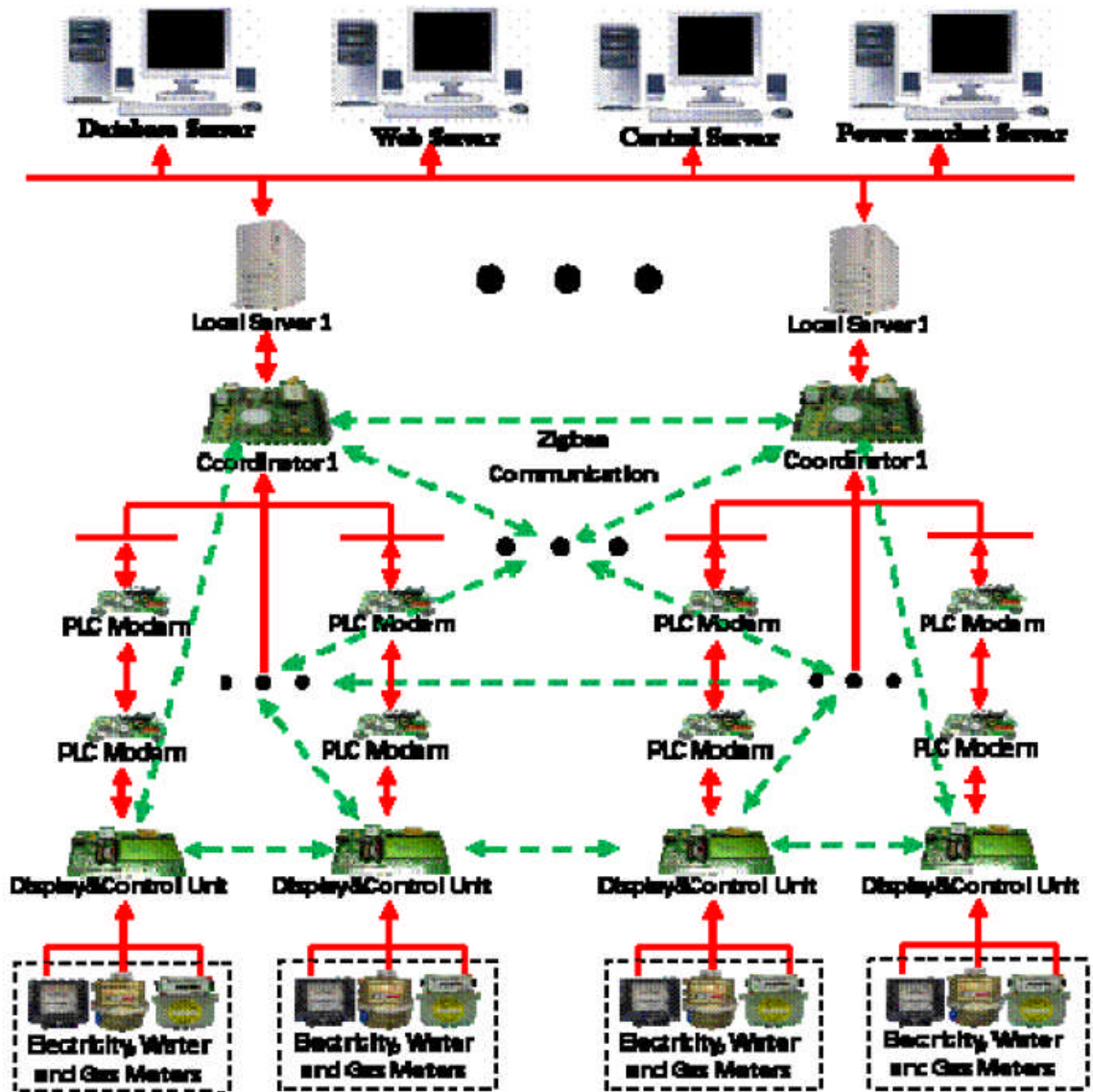

Figure 1



Figure 2

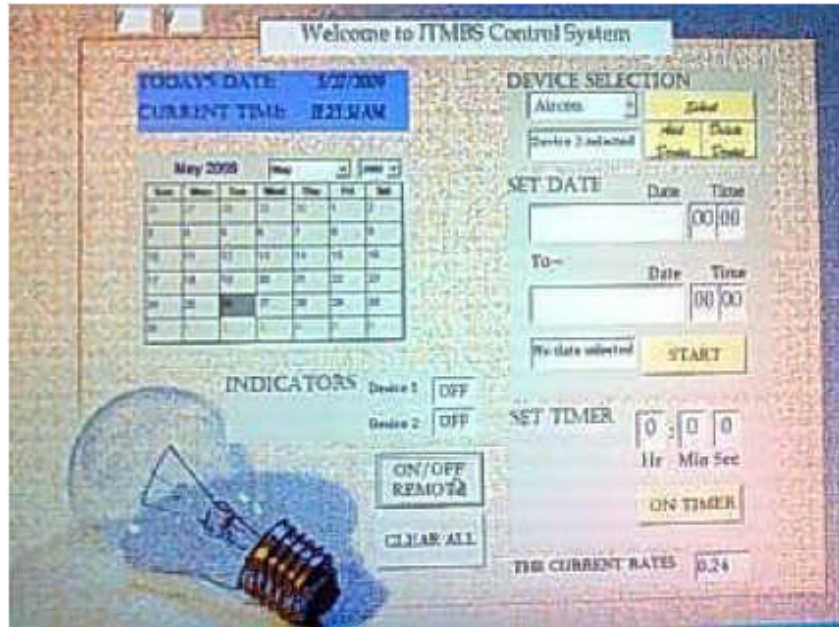

Figure 3

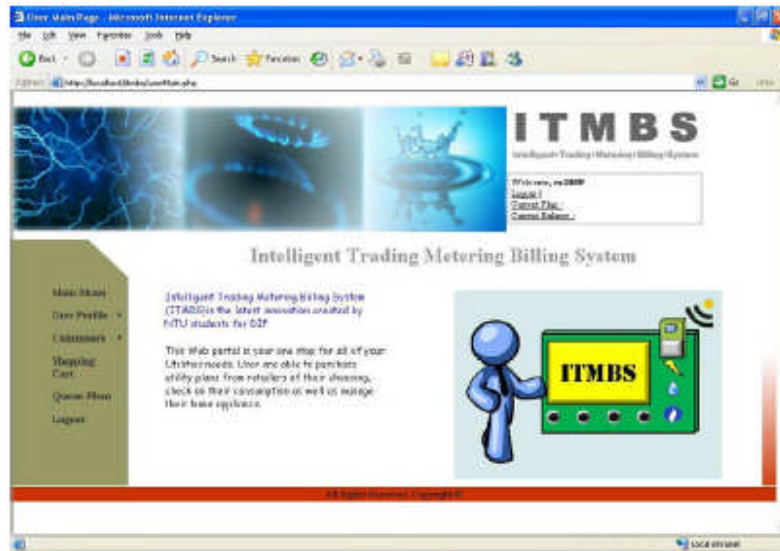

Figure 5

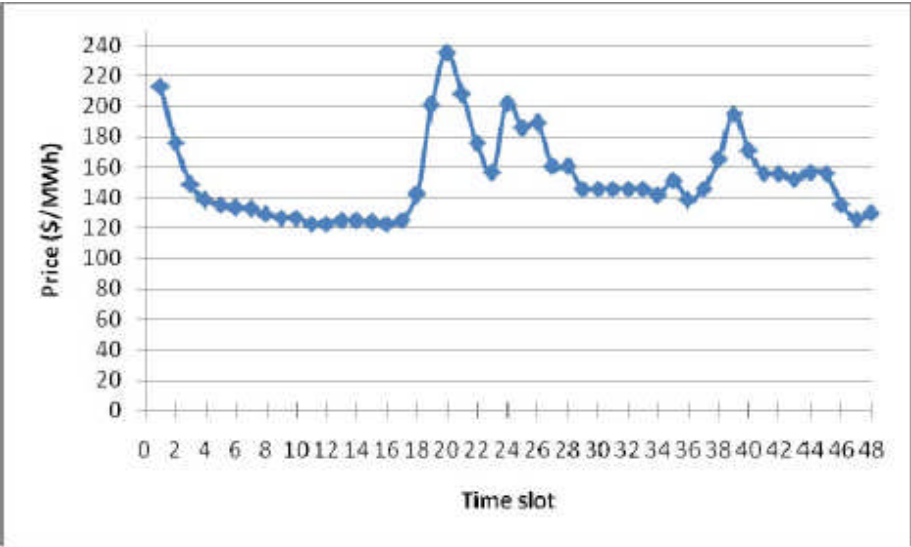

Figure 6

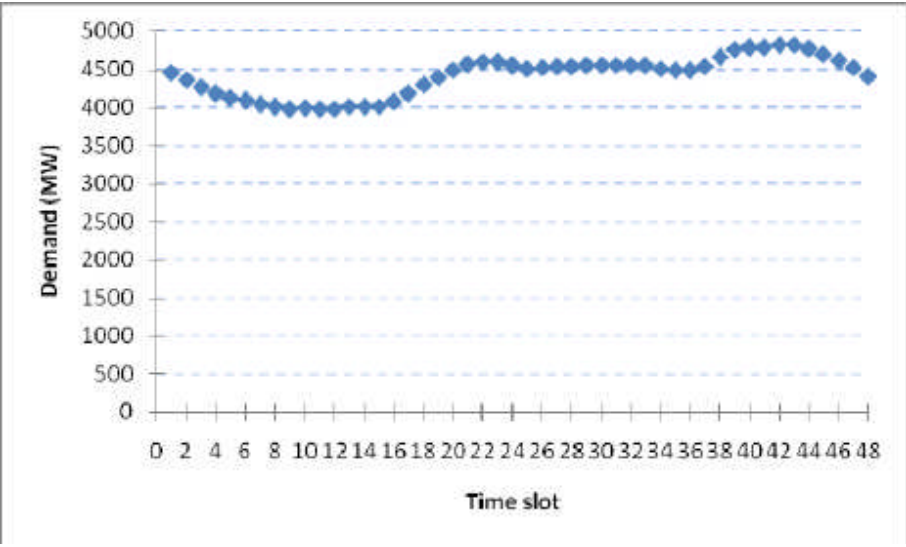

Figure 7