

# Bioinspired fibrillar adhesives: a review of analytical models and experimental evidence for adhesion enhancement by surface patterns.

R. D. O'Rorke<sup>1</sup>, T. W. J. Steele<sup>1†\*</sup>, and H. K. Taylor<sup>2††\*</sup>

<sup>1</sup> School of Materials Science and Engineering,  
Nanyang Technological University, Singapore.

<sup>2</sup> Department of Mechanical Engineering,  
6159 Etcheverry Hall,  
University of California, Berkeley, CA 94720 U.S.A.

† [wjsteele@ntu.edu.sg](mailto:wjsteele@ntu.edu.sg)

†† [hkt@berkeley.edu](mailto:hkt@berkeley.edu)

\* Corresponding authors

September 9, 2015

<sup>1</sup> For publication in the Journal of Adhesion Science and Technology

## Abstract

Fibrillar structures are found on the attachment pads of insects and small reptiles. These structures enable exquisite conformation to rough surfaces, increase the number of van der Waals interactions between the structure and the target surface, and thus enhance adhesion. Biomimetic adhesives replicate this effect by patterning polymer films with micron- or sub-micron-sized protrusions. Numerical contact-mechanics models as well as experimental adhesion measurements have been reported for a variety of protrusion shapes including flat, rounded, mushroom and spatula geometries. Although superior adhesion has been reported for the mushroom and spatula tip geometries, straight, flat-tipped pillars offer the potential for much simpler mass-production such as by injection moulding and are thus the focus of this review.

Existing models for straight, flat-tipped pillar arrays do not fully agree with reported experimental results. Analytical models are generally limited to elastic materials, and inherently assume that neighbouring pillars behave independently. For elastic pillars in close proximity, however, pillars do in fact interact mechanically, affecting adhesion. Moreover, visco- and hyper-elastic materials are often used in practice, yet dissipative effects receive little attention in analytical models. We find that no study has conclusively investigated the limit of adhesive strength achievable by fibrillar adhesives. It also remains unclear what happens to the adhesive strength as the areal density of contacting regions approaches 100%.

**Keywords:** *Adhesive, bioadhesive, biomimetic, contact mechanics, gecko*

# 1 Introduction

Fibrillar structures are found throughout nature on the attachment pads of insects, spiders, and lizards, allowing both strong adhesion and easy release for locomotion [5, 9, 60, 61]. The very high aspect ratios of these setae ( $> 20$ ) allow exquisite conformation to rough surfaces, since the individual setae can deform more easily than a continuous surface, giving rise to larger contact areas than would otherwise be possible. Such is the increase in contact area that loads from  $\mu\text{g}$  (flies) to 100 g (lizards) can be supported by van der Waals interactions [5]. Fibrillar structures can give rise to strong adhesion for high-Young's-modulus materials, such as beta-keratin in gecko setae which has a Young's modulus of 1.6 GPa [58].

Considerable effort has been invested in developing biomimetic polymer adhesives patterned with pillar arrays of various geometries. Although both friction and adhesion are important in gecko climbing and locomotion [6], most research has focused on fibrillar surfaces for adhesion. Setae geometry is complex and hierarchical in nature, with spatula structures and mushroom, or suction-cup, structures common [25]. Hierarchical geometries are difficult to replicate in synthetic adhesives, and efforts tend to be focused on low aspect ratio ( $< 5$ ) pillars with flat [3, 27, 39, 45–47, 52], rounded [27, 38], spatula [27, 32] or mushroom [25, 27, 41] tips.

Analytical models of fibrillar adhesion have been adapted from the contact mechanics models of Johnson, Kendall and Roberts [36, 37]. A major feature of these analytical models is that the adhesive strength of a single pillar (the adhesive force per unit contact area) increases as pillar diameter decreases, giving rise to an anticipated increase in adhesion beyond increased contact area [5]. A primary research goal is to elucidate the effects of pillar geometry and density on adhesion, which is still not fully understood. Furthermore, testing protocols, substrates, and pillar geometries vary greatly between studies, making direct comparison of reported data difficult.

There are several excellent reviews of gecko adhesion models [8, 40, 79]. These reviews focus on gecko adhesion and locomotion, giving less attention to synthetic gecko adhesives, which is the focus of this review. Here, we examine analytical models of fibrillar adhesion, discuss

50 the contact mechanics principles on which they are based, and review reported data on fibrillar  
51 adhesives. Whilst we briefly discuss tilted pillars and pillars with spatula and mushroom tips,  
52 this review focuses on straight, flat-tipped pillars because of the relative ease with which these  
53 simple geometries could be produced using standard manufacturing processes, such as injec-  
54 tion moulding [78]. We keep in mind three questions: (1) do the analytical models provide  
55 an accurate approximation to fibrillar adhesives? (2) do fibrillar structures actually enhance  
56 adhesion? and (3) how does pillar geometry influence adhesion?

57 We begin by discussing two fundamental theories of contact mechanics: the Johnson-Kendall-  
58 Roberts (JKR) model [33] and the Derjaguin-Muller-Toporov (DMT) model [20], followed by  
59 applications of JKR theory to fibrillar adhesives [5, 31, 62, 66, 73].

## 60 2 Analytical models of adhesion

61 Table 1 near here.

62 In this section we discuss the complementary JKR and DMT models of contact mechanics,  
63 the circumstances in which each model applies and the analytical models of fibrillar adhesion  
64 that have been developed from JKR theory. There is a key difference between JKR and DMT  
65 theories, in that JKR considers surface forces only in the contact area between two spheres,  
66 whereas DMT also considers the surface forces in a region surrounding the contact area. Both  
67 JKR and DMT theories are developments of the earlier Hertz theory of contact between elastic  
68 spheres, and are illustrated in Figure 1.

### 69 2.1 Hertz, JKR and DMT Theory

70 Figure 1 near here

71 The theories put forward by Johnson *et al.* [33] and Kendall [36, 37] in the 1970's remain  
72 the standard theories for interpretation of adhesion test data to date. Hertz theory provides a  
73 model of contact between two elastic spheres as a function of a compressive load,  $P$ , and does

74 not consider adhesive forces. Johnson, Kendall and Roberts later considered attractive surface  
 75 forces [33, 36, 37].

76 In both JKR and DMT theories adhesion arises from the surface energies of the two spheres.  
 77 Surface energy is defined as the energy required to create unit area of new surface and can  
 78 account for hydrophobic interactions, van der Waals forces, hydrogen bonding, covalent bond-  
 79 ing, *etc.*. The applicability of JKR and DMT theories has been investigated in depth [34, 48,  
 80 50, 67, 70], and the appropriate model can be determined by a single dimensionless parameter  
 81 [34]:

$$\left( \frac{R^* W^2}{E^{*2} z_0^2} \right)^{1/3} \ll 1 \quad \text{for DMT ,} \quad (1)$$

$$\left( \frac{R^* W^2}{E^{*2} z_0^2} \right)^{1/3} \gg 1 \quad \text{for JKR ,} \quad (2)$$

82 where  $W$  is the work of adhesion and  $z_0$  is the equilibrium spacing between atomic planes of  
 83 the contacting spheres in the Lennard-Jones potential.  $R^*$  and  $E^*$  are the reduced radius and  
 84 Young's modulus, respectively, given by:

$$R^* = \frac{R_1 R_2}{R_1 + R_2} \quad , \quad (3)$$

$$E^* = \left( \frac{1 - \nu_1^2}{E_1} + \frac{1 - \nu_2^2}{E_2} \right)^{-1} \quad , \quad (4)$$

85 where  $E$  and  $\nu$  are the Young's modulus and Poisson's ratio and the subscripts 1 and 2 refer  
 86 to the two spheres. The anticipated relationships between compressive load,  $P$ , displacement,  
 87  $\delta$ , contact radius at zero load,  $a_0$ , and adhesive force,  $F$ , predicted by Hertz, JKR and DMT  
 88 theories are summarised in Table 2, where  $\gamma$  is the surface energy, and  $K$ , is given by:

$$K = \frac{4}{3} E^* \quad . \quad (5)$$

89 Table 2 near here.

90 Figure 2 near here.

## 91 2.2 *Specific applications of JKR theory*

92 Kendall applied JKR theory to several specific cases: (a) the flat end of a rigid punch in contact  
93 with an elastic half-space under normal loading; (b) a thin elastic layer between the flat end of  
94 a rigid punch and a flat rigid substrate under normal loading, and; (c) a thin elastic film being  
95 peeled from a flat rigid substrate, as illustrated in Figure 2.

96 For the case of a rigid punch on an elastic half-space, the derivation can be found in Appendix  
97 A, and the adhesive force,  $F$ , is given by:

$$F = \sqrt{8\pi E^* \gamma R^3} . \quad (6)$$

98 For the case of an elastic film between a rigid punch and a rigid half-space the derivation can  
99 be found in Appendix B, and the adhesive force,  $F$ , is given by

$$F = \pi R^2 \sqrt{\frac{2E\gamma}{3t(1-2\nu)}} , \quad (7)$$

100 where  $t$  is the film thickness. Finally, for the case of peeling a thin elastic film from a rigid sub-  
101 strate the derivation can be found in Appendix C, and the adhesive force,  $F$ , is given by

$$F = btE \left[ (\cos \theta - 1) + \sqrt{(1 - \cos \theta)^2 + \frac{4\gamma}{2tE}} \right] . \quad (8)$$

102 Kendall verified Equations 6 and 7 by separating an acrylic punch from both a gelatine block  
103 and a gelatine film [36], and Equation 8 by peeling a thin gelatine sheet from a glass sub-  
104 strate [37]. The elastic strain energy in the peeled film was negligible for peel angles above  
105  $60^\circ$  and the surface energy dominated. For peel angles below  $60^\circ$  the elastic strain energy  
106 dominated.

107 Yang *et al.* independently derived relationships for the adhesive force for an elastic film be-  
 108 tween a rigid punch and a flat rigid substrate [76]. The elastic film behaved as a half-space  
 109 if the film thickness,  $t$ , was more than double the punch radius,  $R$ , and Equation 6 applied.  
 110 For film thickness smaller than one-tenth of the punch radius, the following relationships were  
 111 derived for different boundary conditions at the substrate/film/punch interfaces:

$$F = \pi R^2 \sqrt{\frac{8\mu\gamma}{t}} \quad \text{for slip at both boundaries;} \quad (9)$$

$$F = \frac{\pi R^3}{2t} \sqrt{\frac{3\mu\gamma}{2t}} \quad \text{for slip at one boundary;} \quad (10)$$

$$F = \frac{\pi R^3}{t} \sqrt{\frac{3\mu\gamma}{2t}} \quad \text{for stick at both boundaries,} \quad (11)$$

112 where the shear modulus,  $\mu$ , is given by:

$$\mu = \frac{E}{2(1 + \nu)} . \quad (12)$$

113 This model has not been experimentally verified, and Equation 9, for stick at both boundaries,  
 114 is not consistent with Kendal's equivalent model, Equation 7.

### 115 2.3 Contact-splitting theory

116 Arzt *et al.* determined the adhesive force for an array of pillars with convex tips using JKR  
 117 theory, in what has become known as contact-splitting theory [5]. This theory was originally  
 118 presented to describe the scaling of setae density with mass in insects and lizards [5]. However,  
 119 this has since been discredited by Peattie, who found no correlation between setae density and  
 120 body mass in a larger study [57]. Nonetheless, contact splitting theory gives an interesting  
 121 insight into how the size and number of pillars in an array can influence adhesion, as we will  
 122 now discuss.

123 A convex-ended pillar of radius  $R_0$  is divided into an array of  $n$  convex-ended pillars of radius

124  $R$ , where  $R = \frac{R_0}{\sqrt{n}}$  (i.e. the cross-sectional area of the pillar array is equal to that of the starting  
 125 pillar), as illustrated in Figure 3. The radius of curvature of the convex tips can be equal to  
 126  $R$  (self-similar scaling), or equal to  $R_0$  (curvature invariance). The adhesive force,  $F_T$ , for the  
 127 array of pillars, relative to that for a single pillar,  $F_0$ , is given by:

$$F_T = n^q F_0 , \quad (13)$$

128 where  $q = 0.5$  for self-similar scaling and  $q = 1$  for curvature invariance. The derivation of  
 129  $F_T$  for curvature invariance and self-similar scaling is provided in Appendix D. Spolenak *et*  
 130 *al.* independently investigated contact splitting and derived the same relationship as Arzt for  
 131 curvature invariance and self-similar scaling [68]. Spolenak also considered a flat punch, for  
 132 which  $q = 0.25$ .

133 Figure 3 near here.

134 The effect of the contact splitting on adhesive force can be understood by considering the con-  
 135 tact area for each case [75]. The contact radius at zero load (given by JKR theory) depends  
 136 on the radius of the pillar tip, which does not change for curvature-invariance, meaning the  
 137 contact radius scales with  $n$ , and the increase in adhesive force is trivial. For self-similar scal-  
 138 ing, however, the contact radius at zero load scales with  $n^{\frac{2}{3}}$ , slightly faster than adhesive force,  
 139 which scales with  $n^{0.5}$ . In other words, contact splitting for rounded pillars offers no benefit  
 140 over using a larger single contact for curvature invariance and is actually disadvantageous for  
 141 self-similar scaling. For a flat punch the contact area must scale with the density of contacts, or  
 142 areal density, after contact splitting, as shown experimentally by Varenberg [75].

143 To achieve a larger contact area a larger preload is required. The relationship between preload  
 144 and contact area is given by [36]:

$$a^3 = \frac{RP}{K} . \quad (14)$$

145 By equating Equation 14 with the JKR contact radius at zero load,  $a_0$ , (see Table 2), it is easy to

146 see that the preload has the same scaling with  $n$  as adhesive force for both curvature invariance  
147 and self-similar scaling.

## 148 2.4 Contact-splitting using a cohesive-zone model

149 Tang *et al.* independently investigated the contact-splitting phenomenon for a rigid punch using  
150 a cohesive zone model [73]. The concept of a cohesive zone has been discussed extensively in  
151 relation to fracture mechanics [4, 7, 21]. The cohesive zone is a region of length  $l$  immediately  
152 outside of the contact area where two surfaces are separated by a distance,  $\delta$ , but remain held by  
153 adhesive forces, as illustrated in Figure 4. Once separated by a critical distance,  $\delta_c$ , the surfaces  
154 separate [73]. Tang investigated the limits of  $R \approx l_c$  where the cohesive zone occupies most  
155 of the contact area, and  $R \gg l_c$  where the cohesive zone occupies only a small amount of the  
156 contact area. The adhesive strength,  $\sigma$ , was found to be

$$\sigma = \sigma_0 B \chi^{-\lambda}, \quad (15)$$

157 where  $B$  and  $\lambda$  are constants and  $\chi$  is given by

$$\chi = \frac{\sigma_0^2 R}{2\pi E^* W} \equiv \frac{\sigma_0 R}{2\pi E^* \delta_c}. \quad (16)$$

158 The theoretical maximum adhesive strength,  $\sigma_0$  is a material property estimated to be  $\frac{E}{10}$ . In the  
159 limit of  $R \approx l_c$ ,  $\chi \ll 1$  and the adhesion is flaw-insensitive. In the limit  $R \gg l_c$ ,  $\chi \gg 1$   
160 and adhesion is flaw-sensitive. Tang verified this model by finite element modelling and found  
161  $\lambda = 0.4$ .

162 Figure 4 near here.

163 If we take Tang's value of  $\lambda$ , we can calculate the scaling of adhesive force with  $n$  (see Equa-  
164 tion 13), and find that  $q = 1.6$ . This is significantly larger than Spolenak's prediction of  
165  $q = 0.25$ .

## 166 2.5 Peel zone model of a thin elastic film

167 Similarly, Pesika *et al.* modified Kendall's peeling model (Equation 8) to include the region  
168 immediately outside the contact area where the adhesive is deformed to produce cavities, yet  
169 remains adhered to the substrate, which they called the peel zone [62]. Pesika assumed that  
170 the elastic film has a sufficiently high modulus that elastic strain in the film can be neglected  
171 and Equation 8 can be approximated by  $F_{surf}$  (see Appendix C). The peeling force,  $F$ , is given  
172 by:

$$F = \left( \frac{\theta}{\theta_0} \right) \left( \frac{1 - \cos \theta_0}{\sin \theta} \right) F_{surf} , \quad (17)$$

173 where

$$F_{surf} = \frac{b\gamma}{1 - \cos \theta} , \quad (18)$$

174 and  $\theta_0$  is the angle between the film and the substrate at the edge of the peeling zone. Equa-  
175 tion 17 was shown to accurately model the peeling force of double-sided adhesive tape when  
176 peeled from borosilicate glass at peeling angles from 30–90° [62].

177 Zhou *et al.* later considered the effect of peeling velocity, and found that the peeling force  
178 followed a power law relationship with peeling velocity [81]. Zhou also developed a design  
179 map for fibrillar adhesives that allow high normal adhesive loads and low peeling strength for  
180 easy removal [80]. Zhou found that high peeling strength favours small radius, high aspect ratio  
181 pillars with low Young's modulus and thick backing layers [80]. Comparison with Equation 8  
182 shows that pillars reduce the peeling strength dramatically for thin backing layers, whilst the  
183 peeling strength converges with Equation 8 for thick backing layers [80]. However, there has  
184 been no experimental verification of Zhou's model, and high aspect-ratio pillars are prone to  
185 collapsing into clumps of pillars, which is detrimental to adhesion [1].

## 186 2.6 Spring Contact Theory

187 Contact-splitting theory inherently assumes that each fibre in an array experiences an identical  
 188 stress, which is not applicable when considering adhesion to spherical substrates, which are  
 189 used widely in adhesion testing. When spherical substrates are used the stress on each fibre  
 190 varies significantly across the contact area from tensile at the perimeter to compressive in the  
 191 centre. Spring contact theory treats each pillar as a linear elastic spring and there must be zero  
 192 net strain across the array of springs at zero applied load, as illustrated in Figure 5 [66].

193 Figure 5 near here.

194 As the sphere is separated from the adhesive, the outer springs extend to a maximum length,  
 195  $l_{max}$ , where the strain energy equals the work of fracture of the interface, and the outer springs  
 196 detach, reducing the contact area whilst the central springs remain compressed. When a criti-  
 197 cal contact radius,  $a_{crit}$ , is reached, the remaining springs cannot support the load and detach  
 198 simultaneously. The critical contact radius,  $a_{crit}$ , is given by:

$$a_{crit} = \sqrt{2R_{probe}(l_{max} - l_0)} . \quad (19)$$

199 Spring contact theory also provides a model for pressure sensitive adhesion, since the number  
 200 of springs in contact with the sphere is dependent on the preload. The preload-dependent pull-  
 201 off force,  $F_P$ , is given by:

$$F = 2\sqrt{(F_{max}P)} - P \quad \text{if } a \leq a_{crit} , \quad (20)$$

$$F_{max} = \frac{\pi E}{4R_{probe}l_0} a_{crit}^4 \quad \text{if } a \geq a_{crit} , \quad (21)$$

202 where  $l_0$  is the equilibrium spring length (analogous to pillar height),  $P$  is the preload,  $a$  is the  
 203 contact radius, and  $R_{probe}$  is the radius of the sphere.  $F_{max}$  occurs when the maximum contact  
 204 area at zero load for the array of springs is reached. The Young's modulus of the spring array  
 205 is given by:

$$E = \frac{l_0 k}{A_0}, \quad (22)$$

206 where  $k$  is the spring constant and  $A_0$  is the area of contact above each spring. This model has  
 207 been shown to accurately describe previously reported experimental data by fitting the value of  
 208  $F_{max}$  [66].

## 209 2.7 Buckling analysis

210 As we have seen, higher preloads are required to bring fibrillar arrays into contact than for a  
 211 single, continuous contact. However, increasing the preload will eventually lead to buckling  
 212 of the fibres. Whilst this may be required for conformation to rough substrates, it can be  
 213 detrimental to adhesion against flat substrates. The critical stress at which buckling occurs,  
 214  $\sigma_{buckle}$ , has been investigated for an array of pillars by Jagota *et al.* [31], and is given by

$$\sigma_{buckle} = E\rho \frac{\pi^2}{3} \left(\frac{1}{\alpha}\right)^2, \quad (23)$$

215 where  $\alpha$  is the aspect ratio and  $\rho$  is the areal density of pillars. Equation 23 is consistent with  
 216 buckling criteria for patterned elastomeric stamps [29]. Nadermann has shown that shearing  
 217 reduces the critical buckling stress [51].

## 218 2.8 Energy dissipation in fibrillar structures under peel

219 In a purely elastic system, the work of adhesion is determined by the surface energies at the  
 220 interface. In reality, adhesive materials may be dissipative, which can serve to increase the  
 221 work of adhesion and adhesive force as a function of the time-scale of separation.

222 Jagota *et al.* considered this problem and speculated that all strain energy stored in an array  
 223 of pillars is dissipated upon separation [31]. The work of adhesion,  $W$ , per unit area for a  
 224 patterned surface is given by

$$W = W_0 + \frac{\rho\gamma^2 h}{2E}, \quad (24)$$

225 where  $W_0$  is the work of adhesion per unit area for a non-patterned surface. Although not stated  
226 by Jagota, the surface energy inherent in  $W_0$  should also be multiplied by the areal density,  $\rho$ ,  
227 to account for the reduced surface area of fibrils in contact with a flat substrate. In support of  
228 Equation 24, Jagota points out that a fracture energy for rubber larger than the thermodynamic  
229 work of adhesion has been reported and attributed to energy dissipation along polymer chains  
230 [43, 44].

## 231 2.9 Summary

232 The analytical models of adhesion presented focus on specific geometries and configurations  
233 that represent only a small number of the likely practical scenarios. For example, peeling a rigid  
234 film from an elastic half-space would better approximate the removal of a bioadhesive film;  
235 multi-layered films of different Young's moduli would be appropriate for pressure-sensitive  
236 adhesives, and; elastic pillars in contact with a rigid substrate would be appropriate for the ma-  
237 jority of reported fibrillar adhesives, which will be discussed in the subsequent section.

238 Nonetheless, these analytical models provide a starting point for the design and interpretation  
239 of fibrillar adhesives. On the one hand, contact splitting tells us that an increasing number of  
240 sub-contacts allow for larger contact areas and, thus, increased adhesive forces. Spring contact  
241 theory also tells us that taller, thinner fibres offer improved adhesive force. On the other hand,  
242 fibrillar geometries require a larger preload to establish contact. Dense arrays of high aspect  
243 ratio, small radius pillars are prone to *condensation*, where neighbouring pillars collapse into  
244 one another. A useful model of pillar condensation was developed by Ahmadi *et al.* [1].

245 In the following section we discuss the experimental evidence of fibrillar adhesives in the con-  
246 text of the analytical models. We only include work that directly compares the adhesion of  
247 fibrillar and non-patterned adhesives, where the effect of fibrillar geometry on adhesion is in-  
248 vestigated.

## 249 3 Review of experimental data

250 Fibrillar structures can benefit adhesion in two ways: (1) through improved compliance, and  
251 (2) increased adhesive strength. The following review of experimental data aims to answer  
252 several questions: (1) is there convincing evidence for adhesion enhancement in using fibrillar  
253 arrays? (2) what are the practical limitations on pillar geometry and density? and (3) what  
254 role does energy dissipation play in adhesion of fibrillar structures? Where possible we refer to  
255 the relative adhesive force and strength, which is the ratio of adhesive forces or strengths for a  
256 patterned and non-patterned adhesive.

257 Reported adhesive forces and strengths are summarised for a range of loading conditions and  
258 pillar geometries in Table 4 and Table 5. The relative adhesive forces from numerous studies  
259 are plotted as a function of geometrical parameters in Figure 6.

260 Figure 6 near here.

### 261 3.1 *Choice of adhesion test*

262 Fibrillar adhesives are usually tested under normal loading conditions [3, 10, 23, 27, 39, 46,  
263 52, 54, 72, 74], although peel adhesion [25, 41, 45, 56] and shear adhesion [32, 38, 47] have  
264 been reported. This preference likely arises from the application of analytical models to normal  
265 loading and peeling. The effect of pillar geometry on adhesion is markedly different for out-  
266 of-plane loading (normal and peel) than in-plane loading (shear), as we discuss later.

267 For perfectly flat substrates and uniform, flat-ended pillars, the adhesive force is largely in-  
268 dependent of preload [25, 39, 54]. The exception to this is when fibres are not perpendicular  
269 to the surface, resulting in a misalignment of the loading direction, causing preload depen-  
270 dence [16, 39, 59]. For curved substrates, adhesion is preload dependent, or pressure-sensitive  
271 [3, 13, 16, 27, 39, 59].

## 272 3.2 *Effect of material properties on adhesion*

273 High Young's-modulus materials are expected to be beneficial for adhesives, since JKR theory  
274 predicts that adhesive force scales with  $\sqrt{E}$ . By far the most popular choice of material for  
275 exploration of contact-splitting is polydimethylsiloxane (PDMS), prepared at a 10:1 volume  
276 ratio of elastomer to cross-linker with a Young's modulus of several MPa [10, 14, 19, 23, 27,  
277 38, 39, 41, 45, 54, 56, 65, 69, 72]. Poly (vinyl siloxane) (PVS) is also used, and has similar  
278 elastic properties to PDMS [24, 25, 59]. With moduli in the GPa range, polyethylene (PE) [52]  
279 and polypropylene (PP) [46] have been reported. Some studies utilise polyurethane (PU) with  
280 Young's moduli of 55–1200 kPa [17], and several MPa [16]. The choice of material depends  
281 largely on the fabrication process, which is the focus of a previous review by Sameoto *et al.*  
282 [64].

283 Figure 7 near here.

284 Castellanos found that adhesive force increased with increasing Young's modulus for low-  
285 Young's-modulus epoxy resins [13], consistent with expectations from analytical models. In  
286 contrast, several studies have shown that adhesive force increases with decreasing Young's  
287 modulus for rough surfaces and both flat [17] and patterned [63] adhesives, and for patterned  
288 adhesives of smooth, curved surfaces [26],

289 In a perfectly elastic system the choice of material will not affect the relative adhesive force.  
290 In reality, however, it is possible that fibrillar structures lead to some energy dissipation during  
291 detachment, which will give rise to a positive effect of Young's modulus on relative adhesive  
292 force and strength. The reported materials span a five-orders-of-magnitude range of moduli  
293 and a range of damping factors, making direct comparison of adhesion difficult. This problem  
294 is compounded by the fact that many studies do not report the material properties.

## 295 3.3 *Effects of fibre geometry on adhesion*

296 *Small radius, high aspect ratio pillars give better adhesion.*

297 Greiner *et al.* reported the adhesion of PDMS films patterned with pillars to a 5-mm-diameter  
298 sapphire sphere, separated at  $1 \mu\text{m s}^{-1}$  following preloads up to 4 mN [27]. Pillar radii from  
299  $1\text{--}25 \mu\text{m}$ , heights from  $2.5\text{--}80 \mu\text{m}$ , and an areal density of 20% were investigated. Adhesive  
300 force was found to be inversely proportional to pillar radius and directly proportional to aspect  
301 ratio. The scaling of adhesive force with radius was comparable to the theoretical predictions of  
302 Spolenak's contact-splitting theory [68]. For an aspect ratio of one and a pillar radius of  $2.5 \mu\text{m}$   
303 Greiner reported an adhesive force of 1.2 mN, exceeding that for a non-patterned adhesive of  
304 0.8 mN. For a radius of  $5 \mu\text{m}$  the adhesive force was comparable to the non-patterned adhesive,  
305 and for a radius of  $25 \mu\text{m}$  the adhesive force was 0.6 mN. Increasing the aspect ratio to four  
306 increased the adhesive force to 1.3 mN for a pillar radius of  $5 \mu\text{m}$ . In a separate study, the  
307 same group reported that rounding the top edges of the pillars reduced the adhesive force from  
308 1.2 mN to 0.8 mN for a pillar radius of  $2.5 \mu\text{m}$  and aspect ratio of one, all other things constant  
309 [19]. This is not surprising, since tip-rounding will reduce the contact area at a given preload  
310 and effectively introduce a crack at the edge of the contact area, facilitating detachment.

311 Atomic force microscopy (AFM) has been used to measure the adhesion of PP pillars to a  
312  $30\text{-}\mu\text{m}$ -diameter glass sphere [46]. PP films with a thickness of 1 mm were patterned with  
313  $30\text{-}\mu\text{m}$ -high pillars with diameters from  $50 \text{ nm}\text{--}5 \mu\text{m}$ . The adhesive force for  $100\text{-nm}$ -diameter  
314 pillars with areal density of 15.7% was 350 nN, approximately 30% larger than the 270 nN  
315 reported for non-patterned PP. Adhesive force increased with decreasing pillar diameter, with  
316 adhesive forces of 150 nN and 100 nN for  $5\text{-}$  and  $14\text{-}\mu\text{m}$ -diameter pillars, respectively, with  
317 an areal density of 30%. A separate study found no significant difference in adhesive force  
318 between non-patterned PP and PP patterned with  $600\text{-nm}$ -diameter pillars with aspect ratio of  
319 50 and an areal density of 17% [52].

320 Lambet *et al.* took a unique approach to peel adhesion by fabricating a single PDMS adhesive  
321 with adjacent flat and patterned regions, and observed the change in peeling load between the  
322 two regions against adhesive tape [45]. The PDMS was patterned with  $2\text{-}\mu\text{m}$ -diameter pillars  
323 with aspect ratio of 0.35 and areal density of 17%. A preload of 50 kPa was applied for 24  
324 hours, and peeling was conducted at  $6 \mu\text{m s}^{-1}$  normal to the surface. The peeling load for the  
325 patterned region was found to be 120 mN, compared to 60 mN for the non-patterned region.

326 The sample width was not disclosed, which precludes analysis of the peeling strength. To  
327 account for penetration of adhesive tape between the pillars, the pillar array was estimated to  
328 increase the surface area by a factor of 1.3. The measured adhesive force ratio of two was  
329 attributed to a combination of increased contact area and increased adhesive strength. Larger  
330 separation rates, higher aspect ratios, and larger areal densities yielded larger adhesive force  
331 ratios, consistent with normal loading observations. In contrast, Aksak reported that the normal  
332 detachment load for a single PU fibre, radius of 0.75 mm with lengths from 0.16–3 mm, from  
333 flat glass decreased with increasing aspect ratio [2].

334 *Higher separation rates give larger adhesive forces.*

335 In contrast to Greiner [27], Kroner reported a loss of adhesion for PDMS patterned with pillars  
336 of radius  $4.7 \mu\text{m}$ , aspect ratios 0.2 and 1.95, and areal density of 20%, using a 5-mm-diameter  
337 glass sphere separated at  $5 \mu\text{m s}^{-1}$  following a 2 mN preload [39]. The adhesive forces for  
338 aspect ratios 0.2 and 1.95 were 1 mN and 1.2 mN, respectively, compared to 4.5 mN for non-  
339 patterned PDMS. The discrepancies between the adhesive force ratios reported by Kroner and  
340 Greiner may arise from the increased separation rate used by Kroner, which can increase energy  
341 dissipation, as found with micro-contact printing using PDMS [15, 77]. PDMS is a hyperelastic  
342 material with a linear stress-strain relationship up to 40% strain [35]. It is not clear if the strains  
343 were in the linear elastic regime in Greiner's and Kroner's works, and dissipation through  
344 fibrillar structures may be different from that in bulk materials [31].

345 Castellanos investigated the effect of separation rate on different epoxy adhesives patterned  
346 with  $9\text{-}\mu\text{m}$ -diameter pillars with aspect ratio 1.1 and areal density 20%, using a 4-mm-diameter  
347 sapphire sphere and preload of 14 mN [13]. Adhesive force increased by an order-of-magnitude  
348 up to 6.8 mN over a range of damping factors from 0.5–0.8. Castellanos also reported a steeper  
349 increase in adhesive force with preload for adhesives with larger damping factors, which was  
350 attributed to a reduced ability to form rapid contact at high damping factors. The rate of in-  
351 dentation during preload was equal to the separation rate, meaning that contact area was also  
352 rate dependent. Rate dependent adhesion was only observed for low damping factor adhesives,  
353 indicating an equilibrium between increased energy dissipation and reduced contact area for

354 larger damping factors.

355 *Areal density can make or break a fibrillar adhesive.*

356 In a separate study by Aksak, PU adhesives with pillar heights from 30–100  $\mu\text{m}$ , diameters from  
357 4–25  $\mu\text{m}$ , and inter-pillar spacing of 40  $\mu\text{m}$  were investigated using a 12-mm-diameter glass  
358 sphere separated at 1  $\mu\text{m s}^{-1}$  [3]. The adhesive force for PU patterned with 25- $\mu\text{m}$ -diameter  
359 pillars was found to be 5 mN for aspect ratio 2.4 and 14 mN for aspect ratio three, significantly  
360 less than 18 mN for non-patterned samples. The areal density was 11.6% in both cases and a  
361 30 mN preload was used (the adhesive force saturated for preloads above 5 mN). The authors  
362 found that non-patterned adhesives also exhibited preload dependence, concluding that viscous  
363 dissipation reduced the adhesive force for patterned adhesives. It is more likely that the areal  
364 density was too low for the chosen pillar radius.

365 The adhesion of polyimide (PI) pillars with diameters from 0.2–4  $\mu\text{m}$ , heights from 0.15–2  $\mu\text{m}$ ,  
366 and pitches comparable to pillar diameter have been reported using a 50- $\mu\text{m}$ -wide flat silicon  
367 AFM tip with a 10 mg preload [22]. The authors found that adhesive forces for all samples  
368 fell on a single curve, with adhesive force inversely proportional to the square of the array  
369 pitch. The authors conclude that adhesive force is directly proportional to areal density and  
370 only weakly dependent on pillar geometry. The authors have assumed that areal density is  
371 proportional to  $\frac{1}{D^2}$ ; however it is actually proportional to  $\frac{R}{D^2}$ . This distinction is important as  
372 the radius is not constant in their work. Taking into account the varying pillar radius, there  
373 is a non-linear correlation between adhesive force and areal density. Significantly different  
374 adhesive forces were reported for different pillar radii at the same areal density, suggesting a  
375 significant dependence on pillar geometry.

376 Tsai *et al.* used flat silicon AFM tips to test the adhesion of square pillars in electron-beam  
377 lithography photoresist (ZEP 520A) with widths from 100–1900 nm, pitches from 200–2000 nm,  
378 and a height of 450 nm [74]. Adhesive strengths increased almost exponentially from 1–8 kPa  
379 with an increase in areal density from 15–90%.

380 Whilst we do not discuss hierarchically structured adhesives in this review, Glassmaker's work  
381 on film-terminated fibrillar adhesives gives an interesting insight into the effect of areal density

382 and contact area [23]. Glassmaker *et al.* studied the adhesion of PDMS films patterned with  
383 square pillars with width of  $14\ \mu\text{m}$ , heights from  $50\text{--}60\ \mu\text{m}$ , and pitches from  $38\text{--}87\ \mu\text{m}$ ,  
384 capped with a  $4\text{-}\mu\text{m}$ -thick PDMS film. A  $3.97\text{-mm}$ -diameter glass sphere was separated at  
385  $1\ \mu\text{m s}^{-1}$ . Increasing array pitch (thus decreasing areal density) was found to increase both the  
386 adhesive force and compliance. The adhesive force of non-patterned PDMS was reported to  
387 be  $2.5\ \text{mN}$ , whilst surface patterns with pitches of  $38$ ,  $62$  and  $87\ \mu\text{m}$  gave adhesive forces of  
388  $5$ ,  $8$  and  $11\ \text{mN}$ , respectively. Evidently applying a continuous film reverses the dependence  
389 of adhesive force on areal density as the surface area is no longer dependent on areal density.  
390 The adhesive force ratio reported by Glassmaker is several times higher than that reported by  
391 Greiner [27] for comparable pillar size, areal density and substrate, owing to an increase in  
392 contact area.

393 *Patterned adhesives are sensitive to substrate curvature and roughness.*

394 A useful comparison between spherical and flat substrates can be found in Kroner's work, using  
395 PDMS adhesives with pillars of radius  $4.7\ \mu\text{m}$ , aspect ratios  $0.2$  and  $0.4$ , and an areal density  
396 of  $20\%$  [39]. The adhesive forces for non-patterned PDMS and PDMS patterned with pillars  
397 of aspect ratio  $0.2$  and  $0.4$  were:  $34$ ,  $12.5$  and  $15\ \text{mN}$ , respectively, for a flat substrate;  $1.9$ ,  $1.6$   
398 and  $0.6\ \text{mN}$ , respectively, for a  $2\text{-mm}$ -diameter substrate, and;  $5$ ,  $1$  and  $1.2\ \text{mN}$ , respectively,  
399 for a  $5\text{-mm}$ -diameter substrate. This comparison shows that adhesive force is highly dependent  
400 on substrate curvature, with patterned surfaces being more sensitive to curvature than non-  
401 patterned surfaces. The authors attribute this effect to misalignment between the spherical  
402 substrate and pillar tips at the edge of the contact region, consistent with measurements against  
403 the curved side of cylindrical probes [59], although misalignment effects are expected to be  
404 minimal with spherical substrates.

405 The effect of substrate roughness on the adhesion of silicon to PDMS pillars with diameters of  
406  $10\ \mu\text{m}$ , aspect ratio two, and mushroom tips was investigated by Canas, using a separation rate  
407 of  $5\ \mu\text{m s}^{-1}$  [10]. The authors reported an almost exponential reduction in adhesive strength  
408 with increasing surface roughness, with adhesive strengths of  $80\ \text{kPa}$  and  $5\ \text{kPa}$  for root-mean-  
409 squared surface roughness of  $2\ \text{nm}$  and  $618\ \text{nm}$ , respectively. The authors concluded that

410 conformation and, hence, adhesion was influenced by the deepest topological features of the  
411 surface.

412 *Adhesion to flat substrates is largely independent of preload.*

413 Paretkar *et al.* investigated the adhesion of PDMS patterned with 10- $\mu\text{m}$ -diameter pillars with  
414 aspect ratio three and areal density of 28%, using a 1-mm-diameter glass cylinder separated  
415 at 1  $\mu\text{m s}^{-1}$  [54]. Non-patterned PDMS exhibited no preload dependence, with a constant  
416 adhesive strength of 8 kPa. In contrast, the adhesive strength for patterned PDMS was 30 kPa at  
417 zero preload and 60 kPa for all preloads up to 120 kPa. For preloads greater than 120 kPa pillars  
418 buckled and flipped into side contact, and the adhesive strength reduced to 1.2 kPa. Hence  
419 the relative adhesive strength was increased 3-fold with no preload and 7.5-fold following the  
420 application of a preload. In separate work, the authors reported a threshold preload value of  
421 0.6 MPa, beyond which PDMS pillars of 10–20  $\mu\text{m}$  diameter and 20  $\mu\text{m}$  height began to buckle,  
422 with pillars eventually making side contact for preloads above 1.25 MPa [53].

423 *Asymmetrical pillars exhibit directional adhesion.*

424 An interesting study has been reported on the directional adhesion of half-cylinder PDMS fibrils  
425 (*i.e.* cylinders with a semi-circular cross-section) with radius of 5  $\mu\text{m}$ , aspect ratio of four, and  
426 areal density of 15% [72]. The authors measured adhesion to a 4-mm-diameter glass puck  
427 for varying preloads, with and without shearing of the pillars prior to separation at 1  $\mu\text{m s}^{-1}$ .  
428 The adhesive force without pre-shearing was 40 mN for the patterned adhesive, compared  
429 to 250 mN for flat PDMS at a preload of 100 mN. Interestingly, the adhesive force for the  
430 fibrillar adhesive could be increased or decreased by a factor of two by shearing in or against the  
431 direction of the flat pillar edge prior to separation, respectively. This arose from the difference  
432 in contact area between the top, flat edge and curved edge faces of the pillar. In a separate study  
433 the authors demonstrated significant preload dependence on adhesion after shearing towards the  
434 curved face [71]. Similarly, Parness *et al.* have shown that wedge-shaped pillars, with a wide  
435 base and narrow tip, exhibit negligible normal adhesion unless the pillars are pre-sheared to  
436 increase the contact area [55].

437 *Adhesion to viscous films is improved with patterned adhesives*

438 Patil investigated adhesion of PDMS patterned with square pillars with widths from 15–450  $\mu\text{m}$ ,  
439 pitch of twice the diameter, and height of 40  $\mu\text{m}$  on a 10- $\mu\text{m}$ -thick backing layer [56]. Instead  
440 of testing adhesion to a rigid substrate, a viscous PDMS (1% crosslinker by volume) film was  
441 cast directly over the adhesive and a flexible glass slide placed on the viscous film prior to peel-  
442 ing at 3  $\mu\text{m s}^{-1}$ . The viscous liquid failed cohesively on non-patterned PDMS and adhesively  
443 on patterned PDMS, with an adhesive force with pillars twice the cohesive without pillars. The  
444 adhesive force was inversely proportional both to pillar width and array pitch.

#### 445 *Lower areal densities improve shear adhesion*

446 Mahdavi *et al.* reported shear adhesion of poly(glycerol sebacate acrylate) (PGSA) adhesives  
447 patterned with conical structures with pillar diameters from 100 nm–1  $\mu\text{m}$  and heights from  
448 0.8–3  $\mu\text{m}$  against porcine intestinal tissue [47]. The separation rate and preload were not dis-  
449 closed. The adhesive force was inversely proportional both to the ratio of tip diameter to pitch,  
450 and the ratio of tip to base diameter. In other words, reducing either tip radius or areal den-  
451 sity increased adhesion, and structures that are more resistant to shear deformation gave rise  
452 to larger adhesive forces. It is not clear from this study whether the pillars penetrated the skin  
453 akin to micro-needle arrays used for trans-dermal drug delivery [28, 30]. The pillars used in  
454 Mahdavi’s work are of much lower heights than those typically used for micro-needle arrays,  
455 owing to the requirement to reach the dermis [30]. However, penetration of the epidermis could  
456 result in mechanical interlocking, rather than gecko-like adhesion.

457 Kramer *et al.* have investigated the shear adhesion of low-aspect-ratio PDMS hemispheres,  
458 with the flat surface presented for adhesion [38]. The authors measured shear adhesion to glass  
459 slides with zero preload, separated at 60  $\text{mm s}^{-1}$ . The authors report adhesive strengths of  
460  $120 \pm 10$  kPa for 50- $\mu\text{m}$ -diameter pillars with areal density 20%, and  $170 \pm 10$  kPa,  $160 \pm 5$  kPa  
461 and  $150 \pm 7$  kPa for 100- $\mu\text{m}$ -diameter pillars with areal densities of 10, 12, and 15%, respec-  
462 tively. These results suggest that adhesive force increases with increasing pitch, consistent with  
463 Mahdavi’s work [47], and contrary to observations of peeling and normal separation.

#### 464 *Pillar angle gives direction-dependent adhesion*

465 Jeong *et al.* investigated shear adhesion of polyurethane acrylate (PUA) adhesives patterned

466 with spatula-tipped pillars with diameters of 700 nm, 350 nm, and 600 nm at the bottom,  
467 neck, and tip respectively [32]. Backing layer thickness values of 50–60  $\mu\text{m}$  were used, and  
468 shear adhesion was measured against the polished and rough faces of a silicon wafer, with a  
469 preload of  $0.3 \text{ N cm}^{-2}$ . The authors reported adhesive strengths against smooth Si of 30 kPa for  
470 smooth PUA and 150 kPa for PUA patterned with vertical pillars. For tilted pillars, the adhesive  
471 strength was 200 kPa and 2 kPa for pillars tilted at  $30^\circ$  towards and against the shear direction,  
472 respectively. For rough Si (rms=674 nm), the adhesive strength was negligible for non-pattered  
473 PUA and 55 kPa, 70 kPa and 15 kPa for vertical pillars and pillars tilted at  $30^\circ$  towards and  
474 against the shear direction, respectively. The adhesive strength against rough surfaces approxi-  
475 mately halved owing to the size of the spatula precluding penetration of the topological features  
476 of the rough Si surface.

477 Similar direction-dependent adhesion has been reported for tilted PDMS pillars that were  
478 sheared in and against the tilt direction during preloading, followed by normal separation [14].  
479 Boesel has also reported direction-dependent adhesion for tilted PUA pillars sheared under con-  
480 stant load [9], as has Kwak for triangular-tipped PDMS pillars peeled from a smooth glass sur-  
481 face [41]. Das *et al* investigated the effect of shear and tilt angle on contact area and found that  
482 contact area increased when sheared in the tilt direction and decreased when sheared against  
483 the tilt direction, and presented an analytical model of contact area consistent with JKR theory  
484 [18].

#### 485 *Mushroom-shaped pillars offer superior adhesion to flat punch*

486 Del Campo *et al.* investigated the detachment load of pillars with different tip geometries using  
487 a 5-mm-diameter sapphire sphere separated normally from the array surface at  $1 \mu\text{m s}^{-1}$  [19].  
488 For pillars with aspect ratio of one, flat punch geometries enhanced adhesion only for a radius  
489 of  $2.5 \mu\text{m}$ , larger radii resulted in reduced adhesion. Rounded punch and convex tip geometries  
490 both resulted in a loss of adhesion for pillar sizes from  $2.5\text{--}25 \mu\text{m}$ . However, mushroom and  
491 spatula tip geometries were found to greatly enhance adhesion for pillar radii of  $10 \mu\text{m}$  and  
492  $25 \mu\text{m}$ . The performance of spatula tip geometries lay between that of flat punch and mushroom  
493 geometries. The radius of the mushroom tip was not found to affect adhesion significantly, in

494 contrast to the underlying pillar radius. The findings of Del Campo are consistent with other  
495 reports of mushroom-tipped pillars [12, 16, 65, 69].

496 Mushroom-shaped PVS pillars have also been investigated for peel adhesion by Gorb *et al.* The  
497 patterned adhesive was peeled from a glass surface by fixing the load and varying the peeling  
498 angle to maintain a separation rate of  $100 \mu\text{m s}^{-1}$ , after a preload of 50–130 mN [25]. The  
499 pillars had base and tip diameters of  $60 \mu\text{m}$  and  $25 \mu\text{m}$ , respectively, height of  $100 \mu\text{m}$ , and a  
500 mushroom tip with diameter of  $40 \mu\text{m}$  and thickness of  $2 \mu\text{m}$ . The peeling strength for patterned  
501 adhesives was  $40 \text{ N m}^{-1}$ , compared to  $22 \text{ N m}^{-1}$  for non-patterned PVS. Gorb used Kendall's  
502 peeling model (Equation 8) to determine the fracture energy of the adhesive, which was found  
503 to be 1.38 and  $0.51 \text{ J m}^{-2}$  for the flat and patterned surfaces, respectively. The peeling force  
504 was independent of preload for both flat and patterned surfaces.

505 Mushroom-shaped pillars have also been tested against human skin [42]. PDMS (7.5% crosslinker)  
506 mushroom-tipped pillars with varying pillar and tip diameter, aspect ratio, and areal density  
507 were tested against the shaved skin on the back of a volunteer's hand under constant load fol-  
508 lowing a preload of  $0.3 \text{ N cm}^{-2}$ . For  $5\text{-}\mu\text{m}$ -diameter pillars with  $9\text{-}\mu\text{m}$ -wide and  $0.6\text{-}\mu\text{m}$ -thick  
509 mushroom cap with an areal density of 20%, the adhesive strength was comparable to non-  
510 patterned PDMS at 5 kPa for aspect ratios of one and two, but increased to 10 kPa and 9 kPa  
511 for aspect ratios of three and four, respectively.

512 The superiority of mushroom geometries is thought to arise from the concentration of stress  
513 within the contact area, as opposed to at the edges of the contact area for flat punch or convex  
514 tip geometries. In the latter, the stress concentration forces detachment to begin at the edges of  
515 the contact area, in contrast to mushroom geometries, in which detachment begins in the centre  
516 of the contact area [11, 12].

## 517 4 Concluding remarks

518 The major findings of this review can be summarised as follows:

- 519 • Small contact radius and large aspect ratios favour adhesion for normal, shear and peel

520 loading

- 521 • Larger adhesive forces are obtained at faster separation rates
- 522 • High areal densities are critical for normal and peel loading
- 523 • Low areal densities are favoured for shear loading
- 524 • Curvature and roughness of the substrate is critical
- 525 • Curved substrates give preload-dependent adhesion, flat substrates do not
- 526 • Asymmetrical or tilted fibres exhibit directional adhesion
- 527 • Fibrillar arrays improve adhesion to viscous films

528 The wide range of materials used for fibrillar adhesives gives rise to a range of Young's mod-  
529 ulus from tens of kPa to several GPa, with varying degrees of viscoelasticity. For viscoelastic  
530 adhesives the adhesive force is rate-dependent, an effect investigated in only a few studies. The  
531 fact that adhesion is dependent on the material properties of the adhesive (in the limiting case  
532 of a rigid substrate the adhesive properties dominate) means that one cannot compare absolute  
533 adhesion between, for example, PDMS and PE. Instead, relative adhesive force and strength  
534 values are more useful measures to determine the efficacy of surface patterning; however, these  
535 can also be dependent on material properties if energy dissipation occurs in the fibrils.

536 The geometric parameters which influence the efficacy of patterned adhesives are fibre diame-  
537 ter, aspect ratio, areal density, and film thickness. We can relate the relationships between these  
538 parameters and adhesive strength to expectations of analytical models. Indeed, it is evident  
539 through numerous studies that decreasing pillar diameter and areal density increases adhesive  
540 strength under normal loading for both flat and spherical substrates, consistent with contact-  
541 splitting theory. However, if we take a step back from individual studies and compare relative  
542 adhesive forces across studies (see Figure 6) we see that, in Glassmaker's work [23], pillar  
543 radius and aspect ratio have little effect on relative adhesive force, whilst areal density has a  
544 profound effect. In Kroner [39] and Aksak's [3] works pillar radius and areal density have little  
545 effect, whereas aspect ratio does, and in Lee's work [46] areal density has little effect, whereas

546 pillar radius and aspect ratio do. Furthermore, we can estimate the relative adhesive force us-  
 547 ing JKR theory (see Appendix E), and we find the following dependencies on areal density,  $\rho$ ,  
 548 pillar radius,  $R$ , and circular geometric area of radius  $R_0$  for several fibre geometries: (1) flat  
 549 punch:

$$\frac{F_{patterned}}{F_{unpatterned}} = \rho^{1.25} R_0^{0.5} R^{-0.5}; \quad (25)$$

550 (2) curvature-invariant convex-ended pillars:

$$\frac{F_{patterned}}{F_{unpatterned}} = \rho^{1.5} R_0 R^{-1}; \quad (26)$$

551 and, (3) curvature-variant convex-ended pillars:

$$\frac{F_{patterned}}{F_{unpatterned}} = \rho^2 R_0^2 R^{-2} . \quad (27)$$

552 Unfortunately no single study investigates a sufficiently wide range of design parameters to  
 553 verify these relationships. Geim *et al.* reported that adhesive force is directly proportional to the  
 554 areal density using convex-ended pillars [22], Tsai *et al.* showed an almost exponential increase  
 555 in adhesive strength with areal density for square posts [74], and Griener *et al.* reported a power  
 556 law relationship between adhesive force and pillar radius with an exponent between -0.4 and -  
 557 0.47 for flat-ended pillars [27]. None of these trends is accurately predicted by contact-splitting  
 558 theory and the disparity becomes even more obvious when estimating the relative adhesive  
 559 force for a given geometry. For an array of pillars with a radius of  $1 \mu\text{m}$ , areal density of 20%  
 560 and geometric radius of 1 cm, there are  $2 \times 10^7$  pillars in the array. The predicted relative  
 561 adhesive forces are 67,  $4.5 \times 10^3$  and  $2 \times 10^7$  for flat punch, self-similar scaling and curvature  
 562 invariance, respectively, which are not consistent with reported data. Furthermore, the influence  
 563 of aspect ratio is not fully considered in analytical models and individual pillars are unlikely to  
 564 behave independently, a central assumption in the models reviewed here.

565 None of the analytical models discussed give insight into the effect of aspect ratio, despite  
566 a positive correlation between aspect ratio and adhesive strength under normal loading for  
567 both flat and spherical substrates. By considering the linear elastic deformation of a cylinder,  
568 it is trivial to show that the load required to impart unit strain energy is proportional to the  
569 square root of aspect ratio. Greiner *et al.* reported that adhesive strength exhibited a power law  
570 relationship with aspect ratio, with an exponent of 0.34. However, the fitted curve from which  
571 the exponent was calculated does not appear to be consistent with the data, and the goodness  
572 of fit is not discussed [27].

573 Surprisingly, areal density has the opposite effect on shear adhesion than that for normal and  
574 peel adhesion. We speculate that this correlation arises from an increasing contact area as pillars  
575 are sheared into side contact, which is reliant upon adequate separation between neighbouring  
576 pillars.

577 Several studies have shown a correlation between adhesive force and separation rate for vis-  
578 coelastic materials, and there are examples of both positive and negative correlations between  
579 adhesion and separation rate for the same pillar geometry using different materials. This lack  
580 of consistency highlights the importance of material properties and the role of viscoelasticity  
581 in fibrillar adhesives, which is not yet fully understood.

582 In conclusion, it is apparent that reducing pillar diameter whilst increasing aspect ratio and areal  
583 density will increase adhesion for out-of-plane loading. In contrast, decreasing areal density is  
584 beneficial for in-plane loading. Although not an accurate model of fibrillar adhesion, the basic  
585 premise of contact-splitting theory — that adhesive strength can be enhanced through the use  
586 of smaller pillars — is supported by numerous studies.

587 Surprisingly, no study has yet identified a limit to the relative adhesion of fibrillar adhesives,  
588 although several authors have reported condensation or buckling of pillars at high aspect ratios.  
589 Pillar radius and aspect ratio are limited by the resolution of the fabrication process and material  
590 properties. The areal density can be increased until the gap between pillars is the limiting  
591 feature size and the adhesive is almost continuous. This poses an interesting question: how  
592 does adhesive strength behave as the gap between the pillars vanishes?

593 There are many interesting studies investigating asymmetrical or angled pillars, pillars with  
594 complex geometries, and hierarchical arrays of pillars-on-pillars, yet a multi-parametric study  
595 of simple flat-ended pillars for a meaningful range of pillar geometries, materials, and load-  
596 ing conditions is lacking. Such a study would be beneficial to understand how geometric pa-  
597 rameters influence adhesion, allowing fibrillar adhesives to be optimised for specific applica-  
598 tions.

599 Table 4 near here.

600 Table 5 near here.

Table 1: Table of symbols. Dashes indicate dimensionless parameters.

Symbol	Description	Units
$\delta$	Displacement	m
$F$	Adhesive force	N
$G$	Adhesive strength	$\text{N m}^{-2}$
$R$	Pillar or sphere radius	m
$h$	Fibril height	m
$\alpha$	Fibril aspect ratio	–
$\rho$	Areal density of fibrils	–
$A$	Geometric area of adhesive	$\text{m}^2$
$n$	Number of fibrils in array	–
$\sigma$	Stress	$\text{N m}^{-2}$
$D$	Array pitch	m
$W$	Work of adhesion	$\text{J m}^{-2}$
$E$	Young's modulus	$\text{N m}^{-2}$
$\nu$	Poisson ratio	–
$\mu$	Shear modulus	$\text{N m}^{-2}$
$\gamma$	Surface energy	$\text{J m}^{-2}$
$z_0$	Equilibrium spacing in Lennard-Jones potential	m
$t$	Film thickness	m
$b$	Film width	m
$\theta$	Peeling angle from surface	deg
$c$	Peeling distance	m
$P$	Preload force	N
$a$	Contact radius	m
$k$	Spring constant	$\text{N m}^{-1}$
$U_E$	Elastic energy	J
$U_P$	Potential energy	J
$U_S$	Surface energy	J

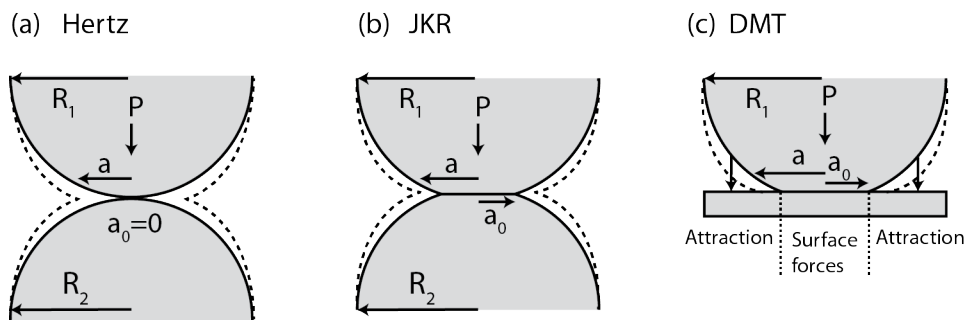

Figure 1: Cross-sectional illustration of the contact between two elastic spheres for (a) Hertz contact, (b) JKR, and (c) DMT models. No interactions are considered in Hertz theory, only surface forces within the contact region are considered in JKR theory, and both surface forces within and attractive forces without the contact region are considered in DMT theory. Solid lines indicate contact configuration at zero load and dashed lines indicate contact configuration for an applied load,  $P$ . (a) and (b) redrawn from [33].

Table 2: Key relationships from Hertz, JKR and DMT theories

Author	Compressive load displacement relationship	Contact radius at zero load	Adhesive force
Hertz [33]	$\delta = \frac{2}{3} \frac{P}{Ka}$	$a_0 = 0$	$F = 0$
JKR [33]		$a_0 = \left( \frac{6\pi\gamma R^{*2}}{K} \right)^{\frac{1}{3}}$	$F = \frac{3}{2}\pi\gamma R^*$
DMT [20, 48, 49]		$a_0 = \left( \frac{4\pi\gamma R^{*2}}{K} \right)^{\frac{1}{3}}$	$F = 2\pi\gamma R^*$

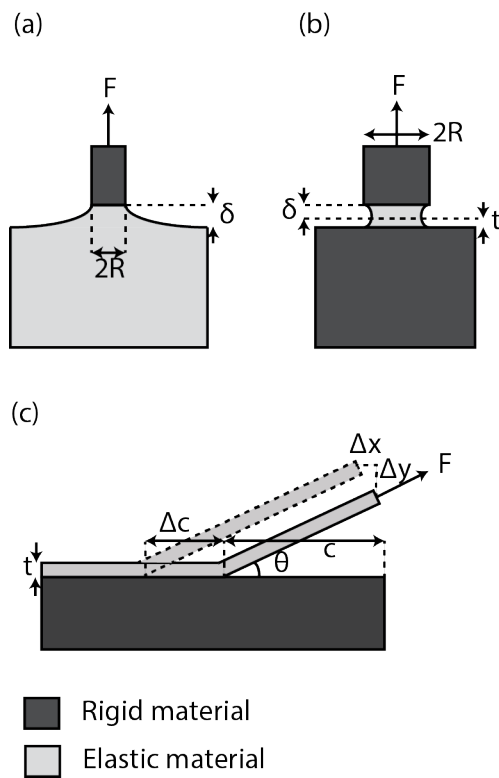

Figure 2: Illustration of the normal separation of (a) a rigid cylinder from an elastic half-space and (b) a thin elastic film between a rigid cylinder and a rigid half-space and (c) an elastic film peeled from a rigid substrate. The un-deformed film thickness is given by  $t$ . Redrawn, with additions, from [36].

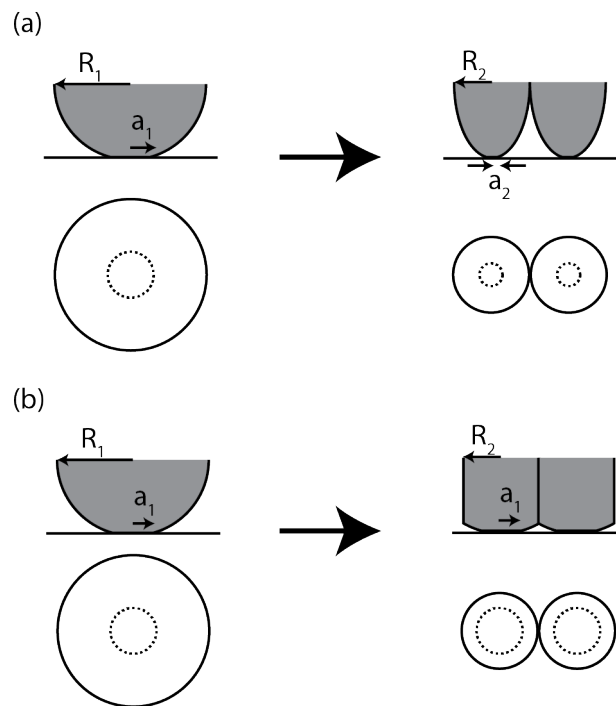

Figure 3: Illustration of the contact-splitting principle for (a) self-similar scaling and (b) curvature invariance. Top-down and side-on views are shown. Dotted lines illustrate actual contact area in top-down view. For self-similar scaling the contact area scales with  $n^{\frac{2}{3}}$  and the adhesive force scales with  $n^{0.5}$ . For curvature invariance the contact area and adhesive force both scale with  $n$ . A value of  $n = 2$  has been used for illustrative purposes.

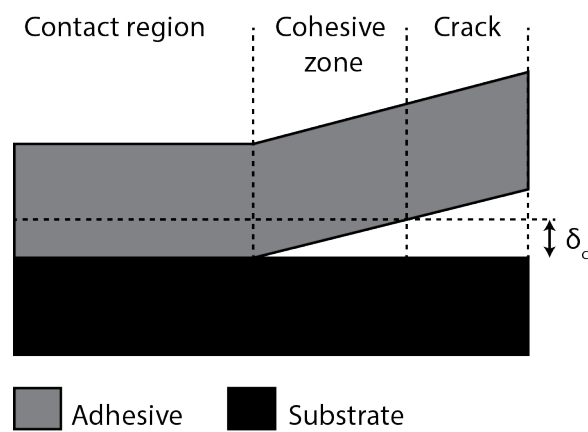

Figure 4: Illustration of the cohesive zone, a region outside the contact region where the interface is separated by less than a critical distance,  $\delta_c$ , and is still held by adhesive forces. For separations greater than  $\delta_c$ , adhesive forces no longer exist and a crack opens.

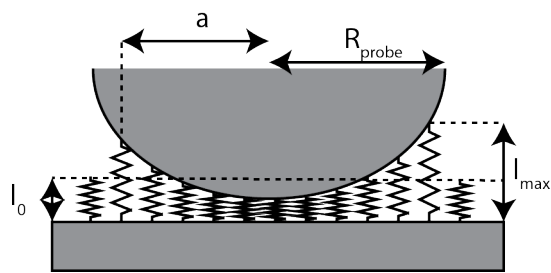

Figure 5: Illustration of the contact between a sphere and a pillar array at equilibrium (i.e. zero load) using spring contact theory - redrawn from [66]

Table 3: Summary of major findings

- 1 Small contact radius and large aspect ratios favour adhesion for normal, shear and peel loading
- 2 Larger adhesive forces are obtained at faster separation rates
- 3 High areal densities are critical for normal and peel loading
- 4 Low area densities are favoured for shear loading
- 5 Curvature and roughness of the substrate is critical
- 6 Curved substrates give preload-dependent adhesion, flat substrates don't
- 7 Asymmetrical or tilted fibres exhibit directional adhesion
- 8 Fibrillar arrays improve adhesion to viscous films

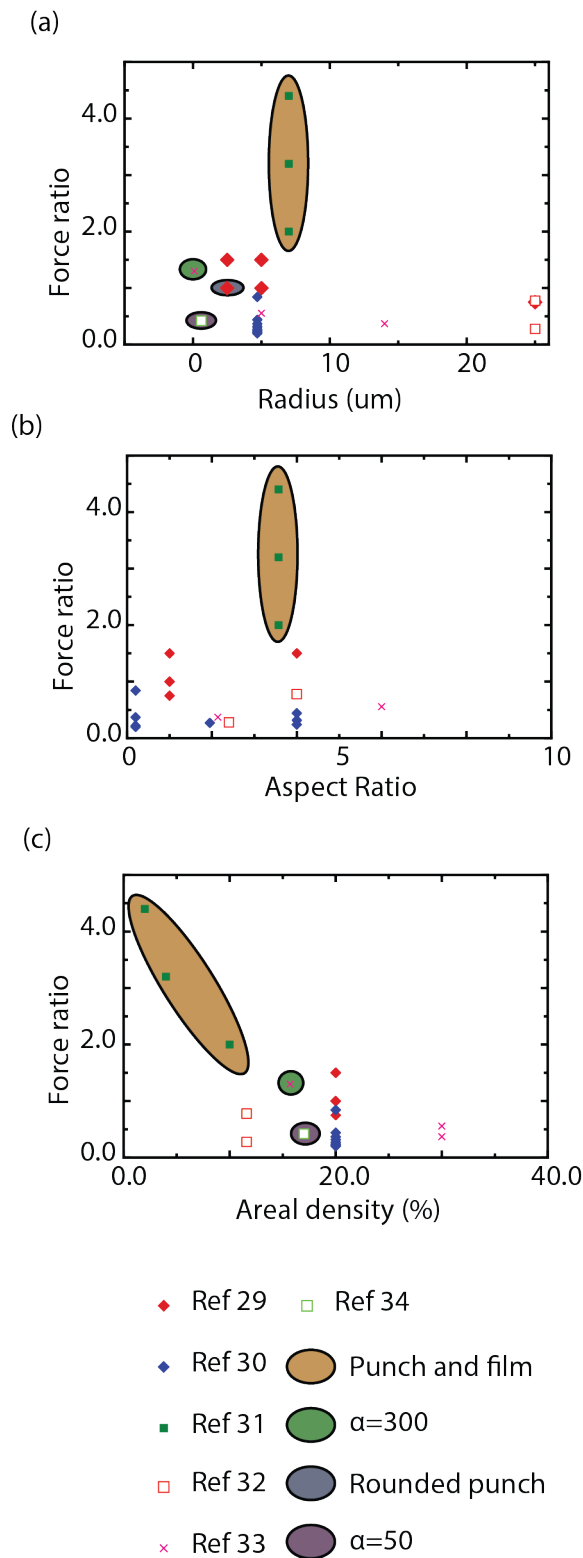

Figure 6: Plots of adhesive force ratio (ratio of adhesive forces for patterned and flat surfaces) under normal loading as a function of (a) fibre radius, (b) aspect ratio and (c) areal density. Values have been taken from Table 4; references are given in the figure legend. Special attention has been drawn to specific data which have unusual properties, such as large aspect ratio and non-standard fibre geometry, where those data points are identifiable.

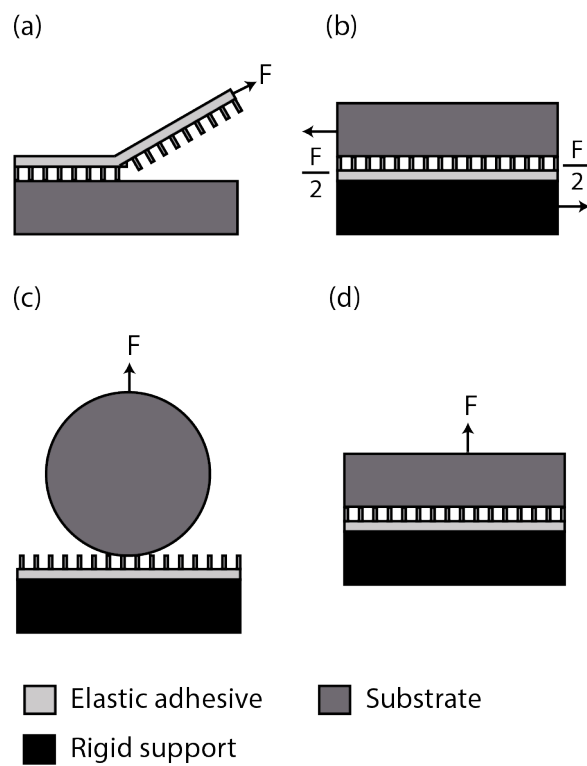

Figure 7: Illustration of different loading configurations for adhesive measurements - (a) peel adhesion, (b) tensile (or shear) adhesion, and normal adhesion using (c) a spherical probe and (d) and a flat probe.

Table 4: Summary of fibrillar adhesive performance under normal loading. For curved substrates, the diameter is given by  $\phi$ .  $R$  is the fibre radius,  $\alpha$  is the aspect ratio,  $\rho$  is the areal density,  $\phi$  is the spherical substrate diameter,  $F$  is the adhesive force and  $G$  is the adhesive strength.

Material	Type	$R$ $\mu\text{m}$	$\alpha$	$\rho$ %	Preload	Rate	$\phi$ $(\mu\text{m s}^{-1})$	$F$	$G$	Adhesive force ratio	Adhesive strength ratio	Ref.
PDMS	Punch	2.5	1	20	4 mN	1	5 mm	1.2 mN	18 kPa	1.50	—	[27]
PDMS	Punch	5	1	20	4 mN	1	5 mm	0.8 mN	12 kPa	1.00	—	[27]
PDMS	Punch	25	1	20	4 mN	1	5 mm	0.6 mN	9 kPa	0.750	—	[27]
PDMS	Punch	5	4	20	4 mN	1	5 mm	1.3 mN	19.5 kPa	1.50	—	[27]
PDMS	Rounded punch	2.5	1	20	4 mN	1	5 mm	0.8 mN	—	1.00	—	[27]
PDMS	Mushroom	25	4	20	10 mN	1	5 mm	5 mN	—	—	—	[27]
PDMS	Spatula	25	4	20	10 mN	1	5 mm	3 mN	—	—	—	[27]
PDMS	Punch	4.7	0.2	20	2 mN	5	5 mm	1 mN	—	0.220	—	[39]
PDMS	Punch	4.7	1.95	20	2 mN	5	5 mm	1.2 mN	—	0.270	—	[39]
PDMS	Punch+ film	7	3.57	10	—	1	3.97 mm	5 mN	—	2.00	—	[23]
PDMS	Punch+ film	7	3.57	4	—	1	3.97 mm	8 mN	—	3.20	—	[23]
PDMS	Punch+ film	7	3.57	2	—	1	3.97 mm	11 mN	—	4.40	—	[23]
PU	Punch	25	2.4	11.6	30 mN	1	12 mm	5 mN	—	0.278	—	[3]
PU	Punch	25	4	11.6	30 mN	1	12 mm	14 mN	—	0.778	—	[3]
PP	Punch	0.1	300	15.7	—	—	30 $\mu\text{m}$	350 nN	—	1.30	—	[46]
PP	Punch	5	6	30	—	—	30 $\mu\text{m}$	150 nN	—	0.556	—	[46]
PP	Punch	14	2.14	30	—	—	30 $\mu\text{m}$	100 nN	—	0.370	—	[46]
PP	Punch	0.6	50	17	—	—	30 $\mu\text{m}$	180 $\pm$ 100 nN	—	0.421–2.55	—	[52]
PDMS	Punch	4.7	0.2	20	—	—	5 mm	1 mN	—	0.200	—	[39]
PDMS	Punch	4.7	4	20	—	—	5 mm	1.2 mN	—	0.240	—	[39]
PDMS	Punch	4.7	0.2	20	—	—	2 mm	1.6 mN	—	0.842	—	[39]
PDMS	Punch	4.7	4	20	—	—	2 mm	0.6 mN	—	0.316	—	[39]
PDMS	Punch	4.7	0.2	20	—	—	Flat	12.5 mN	—	0.368	—	[39]
PDMS	Punch	4.7	4	20	—	—	Flat	15 mN	—	0.441	—	[39]
PDMS	Punch	5	3	28	0	1	Flat	—	30 kPa	—	3.75	[54]
PDMS	Punch	5	3	28	120 kPa	1	Flat	—	60 kPa	—	7.50	[54]
ZEP 520A	Punch	0.05	4.5	15	—	—	Flat	—	1 kPa	—	—	[74]
ZEP 520A	Punch	1.9	4.5	90	—	—	Flat	—	8 kPa	—	—	[74]
PDMS	Half-punch	5	4	15	100 mN	1	Flat	40 mN	—	0.16	—	[72]
PDMS	Punch	5	2	—	—	5	Si (rms=2 nm)	—	80 kPa	—	—	[10]
PDMS	Punch	5	2	—	—	5	Si (rms=618 nm)	—	5 kPa	—	—	[10]

## References

- [1] AHMADI, S., AND MENON, C. A new model for predicting fibre clumping phenomenon in bio-inspired dry adhesives. *The Journal of Adhesion* 90 (2014), 135–155.
- [2] AKSAK, B., HUI, C., AND SITTI, M. The effect of aspect ratio on adhesion and stiffness for soft elastic fibres. *Interface* 8 (2011), 1166–1175.
- [3] AKSAK, B., MURPHY, B., AND SITTI, M. Adhesion of biologically inspired vertical and angled polymer microfiber arrays. *Langmuir* 23, 6 (2007), 3322–32.
- [4] ALFANO, M., FURGIUELE, F., LEONARDI, A., MALETTA, C., AND PAULINO, G. Cohesive zone modelling of mode I fracture in adhesive bonded joints. *Key Engineering Materials* 348-349 (2007), 13–16.
- [5] ARZT, E., GORB, S., AND SPOLENAK, R. From micro to nano contacts in biological attachment devices. *Proceedings of the National Academy of Sciences of the United States of America* 100, 19 (2003), 10603–6.
- [6] AUTUMN, K., HSIEH, S., DUDEK, D., CHEN, J., CHITAPHAN, C., AND FULL, R. Dynamics of geckos running vertically. *The Journal of Experimental Biology* 209 (2005), 260–272.
- [7] BARENBLATT, G. Mathematical theory of equilibrium cracks in brittle features. *Advanced Applied Mechanics* 7 (1962), 55–129.
- [8] BHUSHAN, B., AND SAYER, R. *Nanotribology and Nanomechanics*. 2011.
- [9] BOESEL, L., GREINER, C., ARZT, E., AND DEL CAMPO, A. Gecko-inspired surfaces: a path to strong and reversible dry adhesives. *Advanced Materials* 22, 19 (2010), 2125–37.
- [10] CANAS, N., KAMPERMAN, M., VOLKER, B., KRONER, E., AND MCMEEKING, R. M. Effect of nano and micro roughness on adhesion of bioinspired micropatterned surfaces. *Acta Biomaterialia* 8 (2012), 282–288.
- [11] CARBONE, G., AND PIERRO, E. Sticky bio-inspired micropillars: finding the best shape. *Small* 8 (2012).

Table 5: Summary of fibrillar adhesive performance under shearing (S) and peeling (P).  $R$  is the fibre radius,  $\alpha$  is the aspect ratio,  $\rho$  is the areal density,  $\phi$  is the spherical substrate diameter,  $F$  is the adhesive force,  $G$  is the adhesive strength. PIT refers to porcine intestinal tissue and skin refers to human skin (the back of a hand).

Material	Type	R $\mu\text{m}$	$\alpha$	$\rho$ %	Preload	Rate ( $\mu\text{m s}^{-1}$ )	Mode	Substrate	F	G	Adhesive force ratio	Adhesive strength ratio	Ref.
PDMS	Punch	1	0.35	17	50 kPa	6	P	Glass	120 mN	—	2.00	—	[45]
PDMS	Square post	15	2.67	—	—	3	P	PDMS	450 mN	—	2	—	[56]
PDMS	Mushroom	5, 9	1	20	0.3 Pa	—	P	Skin	—	5 kPa	—	1	[41]
PDMS	Mushroom	5, 9	3	20	0.3 Pa	—	P	Skin	—	10 kPa	—	2	[41]
PVS	Mushroom	25, 40	4	—	130 mN	—	P	Glass	40 N m $^{-1}$	—	1.82	—	[25]
PGSA	Punch	0.18	—	0.34	—	—	S	PIT	—	—	—	2.5	[47]
PGSA	Punch	0.4	—	2.85	—	—	S	PIT	—	—	—	2	[47]
PGSA	Punch	0.4	—	16.6	—	—	S	PIT	—	—	—	1.2	[47]
PUA	Spatula	0.7, 0.35, 600	—	—	3 kPa	—	P	Flat Si	—	150 kPa	—	5	[32]
PDMS	Hemishpere	25	—	10	—	60 10 $^3$	S	Glass	—	120 kPa	—	—	[38]
PDMS	Hemishpere	50	—	10	—	60 10 $^3$	S	Glass	—	170 kPa	—	—	[38]
PDMS	Hemishpere	50	—	12	—	60 10 $^3$	S	Glass	—	160 kPa	—	—	[38]
PDMS	Hemishpere	50	—	15	—	60 10 $^3$	S	Glass	—	150 kPa	—	—	[38]

- 627 [12] CARBONE, G., PIERRO, E., AND GORB, S. Origin of the superior adhesive performance  
628 of mushroom-shaped microstructure surfaces. *Soft Matter* 7 (2011), 5545–5552.
- 629 [13] CASTELLANOS, G., ARZT, E., AND KAMPERMAN, M. Effect of viscoelasticity on  
630 adhesion of bioinspired micropatterned epoxy surfaces. *Langmuir* 27, 12 (2011), 7752–9.
- 631 [14] CHARY, S., TAMELIER, J., AND TURNER, K. L. A microfabricated gecko-inspired  
632 controllable and reusable dry adhesive. *Smart Materials and Structures* 22 (2012).
- 633 [15] CHEN, H., FENG, X., AND CHEN, Y. Directionally controlled transfer printing using  
634 micropatterned stamps. *Applied Physics Letters* 103 (2013).
- 635 [16] CHEUNG, E., AND SITTI, M. Adhesion of biologically inspired polymer microfibrils on  
636 soft surfaces. *Langmuir* 25 (2009), 6613–6616.
- 637 [17] DAI, Z., YU, M., AND GORB, S. Adhesion characteristics of polyurethane for bionic  
638 hairy foot. *Journal of Intelligent Material Systems and Structures* 17 (2006), 737–741.
- 639 [18] DAS, S., CHARY, S., YU, J., TAMELIER, J., TURNER, K., AND ISRAELACHVILI, J.  
640 Jkr theory for the stick-slip peeling and adhesion hysteresis of gecko mimetic patterned  
641 surfaces with a smooth glass surface. *Langmuir* 29 (2013), 15006–15012.
- 642 [19] DEL CAMPO, A., GREINER, C., AND ARZT, E. Contact shape controls adhesion of  
643 bioinspired fibrillar surfaces. *Langmuir* 23, 20 (2007), 10235–43.
- 644 [20] DERJAGUIN, B., MULLER, V., AND TOPOROV, Y. Effect of contact deformations on the  
645 adhesion of particles. *Journal of Colloid and Interface Science* 53, 2 (1975).
- 646 [21] DUGDAL, D. Yielding of steel sheets containing slits. *Journal of the Mechanics and*  
647 *Physics of Solids* 8 (1960), 100–104.
- 648 [22] GEIM, A., DUBONOS, S., GRIGORIEVA, I., NOVOSELOV, K., ZHUKOV, A., AND  
649 SHAPOVAL, S. Microfabricated adhesive mimicking gecko foot-hair. *Nature materials*  
650 2, 7 (2003), 461–3.
- 651 [23] GLASSMAKER, N., AND JAGOTA, A. Biologically inspired crack trapping for enhanced  
652 adhesion. *PNAS* 104, 26 (2007), 1–6.

- 653 [24] GORB, S. J., JIAO, Y., AND SCHERGE, M. Ultrastructural architecture and mechan-  
654 ical properties of attachment pads in *tettigonia viridissima*. *Journal of Computational*  
655 *Physiology* 186 (2000), 821–831.
- 656 [25] GORB, S. N., AND VARENBERG, M. Mushroom-shaped geometry of contact elements  
657 in biological adhesive systems. *Journal of Adhesion Science and Technology* 21, 12-13  
658 (2007), 1175–1183.
- 659 [26] GREINER, C., BUHL, S., DEL CAMPO, A., AND ARZT, E. Experimental parameters  
660 controlling adhesion of biomimetic fibrillar surfaces. *The Journal of Adhesion* 85 (2009),  
661 646–661.
- 662 [27] GREINER, C., CAMPO, A. D., AND ARZT, E. Adhesion of bioinspired micropatterned  
663 surfaces: effects of pillar radius, aspect ratio, and preload. *Langmuir* 23, 7 (2007), 3495–  
664 502.
- 665 [28] HENRY, S., MCALLISTER, D., ALLEN, M., AND PRAUSNITZ, M. Microfabricated  
666 microneedles: a novel approach to transdermal drug delivery. *Journal of pharmaceutical*  
667 *sciences* 87 (1998), 922–925.
- 668 [29] HUI, C.-Y., AND JAGOTA, A. Constraints on microcontact printing imposed by stamp  
669 deformation. *Langmuir* 18 (2002), 1394–1407.
- 670 [30] INDERMUN, S., LUTTGE, R., CHOONARA, Y., KUMAR, P., DU TOIT, L., MODI, G.,  
671 AND PILLAY, V. Current advances in the fabrication of microneedles for transdermal  
672 drug delivery. *Journal of Controlled Release* 185 (2014), 130–138.
- 673 [31] JAGOTA, A., AND BENNISON, S. J. Mechanics of adhesion through a fibrillar mi-  
674 crostructure. *Integrative and comparative biology* 42, 6 (2002), 1140–5.
- 675 [32] JEONG, H., LEE, J., KIM, H., MOON, S. H., AND SUH, K. Y. A nontransferring dry  
676 adhesive with hierarchical polymer nanohairs. *Proceedings of the National Academy of*  
677 *Sciences of the United States of America* 106, 4 (2009), 5639–5644.

- 678 [33] JOHNSON, K. Surface energy and the contact of elastic solids. *Proceedings of the Royal*  
679 *Society A* 324 (1971), 301–313.
- 680 [34] JOHNSON, K., AND GREENWOOD, J. An adhesion map for the contact of elastic spheres.  
681 *Journal of Colloid and Interface Science* 192 (1997), 326–333.
- 682 [35] JOHNSTON, I., MCCLUSKEY, D., TAN, C., AND TRACEY, M. Mechanical characteri-  
683 sation of bulk sylgard 184 for microfluidics and microengineering. *Journal of Microme-*  
684 *chanics and Microengineering* 24 (2014).
- 685 [36] KENDALL, K. The adhesion and surface energy of elastic solids. *Journal of Physics D:*  
686 *Applied Physics* 4 (1971), 1186–1195.
- 687 [37] KENDALL, K. Thin-film peeling—the elastic term. *Journal of Physics D: Applied Physics*  
688 8 (1975), 1449–1452.
- 689 [38] KRAMER, R., MAJIDI, C., AND WOOD, R. Shear-mode contact splitting for a micro-  
690 textured elastomer film. *Advanced Materials* 22 (2010), 3700–3703.
- 691 [39] KRONER, E., PARETKAR, D., MCMEEKING, R., AND ARZT, E. Adhesion of flat and  
692 structured pdms samples to spherical and flat probes: A comparative study. *The Journal*  
693 *of Adhesion* 87, 5 (2011), 447–465.
- 694 [40] KWAK, J., AND KIM, T. A review of adhesion and friction models for gecko feet. *Inter-*  
695 *national Journal of Precision Engineering and Manufacturing* 11 (2010), 171–186.
- 696 [41] KWAK, M., JEONG, H., BAE, W., JUNG, H., AND SUH, K. Y. Anisotropic adhesion  
697 properties of triangular-tip-shaped micropillars. *Small* 7, 16 (2011), 2296–2300.
- 698 [42] KWAK, M., JEONG, H., AND SUH, K. Y. Rational design and enhanced biocompatibility  
699 of a dry adhesive medical skin patch. *Advanced Materials* 23 (2011), 3949–3953.
- 700 [43] LAKE, G. Fatigue and fracture of elastomers. *Rubber Chemistry and Technology* 68  
701 (1995), 435–460.
- 702 [44] LAKE, G., AND THOMAS, A. The strength of highly elastic materials. *Proceedings of*  
703 *the Royal Society A* 300 (1967), 108–119.

- 704 [45] LAMBLET, M., VERNEUIL, E., VILMIN, T., BUGUIN, A., SILBERZAN, P., AND  
705 LÉGER, L. Adhesion enhancement through micropatterning at polydimethylsiloxane-  
706 acrylic adhesive interfaces. *Langmuir* 23, 13 (2007), 6966–74.
- 707 [46] LEE, H., AND BUSHAN, B. Fabrication and characterisation of hierarchical nanostruc-  
708 tured smart adhesion surfaces. *Journal of Colloid and Interface Science* 372 (2012),  
709 231–238.
- 710 [47] MAHDAVI, A., FERREIRA, L., SUNDBACK, C., NICHOL, J., CHAN, E., CARTER,  
711 D. J., BETTINGER, C., PATANAVANICH, S., CHIGNOZHA, L., BEN-JOSEPH, E.,  
712 GALAKATOS, A., PRYOR, H., POMERANTSEVA, I., MASIAKOS, P., FAQUIN, W.,  
713 ZUMBUEHL, A., HONG, S., BORENSTEIN, J., VACANTI, J., LANGER, R., AND KARP,  
714 J. A biodegradable and biocompatible gecko-inspired tissue adhesive. *Proceedings of the*  
715 *National Academy of Sciences of the United States of America* 105, 7 (2008), 2307–12.
- 716 [48] MAUGIS, D. Adhesion of spheres: the jkr-dmt transition using a dugdale model. *Journal*  
717 *of Colloid and Interface Science* 150, 1 (1992).
- 718 [49] MULLER, V., DERJAGUIN, B., AND TOPOROV, Y. On two methods of calculation of  
719 the force of sticking of an elastic sphere to a rigid plane. *Colloids and Surfaces* 7 (1983),  
720 251.
- 721 [50] MULLER, V., YUSHENKO, V., AND DERJAGUIN, B. On the influence of molecular  
722 forces on the deformation of an elastic sphere and its sticking to a rigid plane. *Journal of*  
723 *Colloid and Interface Science* 77, 91 (1980).
- 724 [51] NADERMANN, N., KUMAR, A., GOYAL, S., AND HUI, C. Buckling of sheared and  
725 compressed microfibrils. *Interface* 7 (2010), 1581–1589.
- 726 [52] PALACIO, M., BUSHAN, B., AND SCHRICKER, S. Gecko-inspired fibril nanostructures  
727 for reversible adhesion in biomedical applications. *Materials Letters* 92 (2013), 409–412.
- 728 [53] PARETKAR, D., BARTLETT, M., MCMEEKING, R., CROSBY, A., AND ARZT, E. Buck-  
729 ling of an adhesive polymeric micropillar. *The Journal of Adhesion* 89 (2013), 140–158.

- 730 [54] PARETKAR, D., KAMPERMAN, M., SCHNEIDER, A., MARTINA, D., CRETON, C.,  
731 AND ARZT, E. Bioinspired pressure actuated adhesive system. *Materials Science and*  
732 *Engineering: C* 31, 6 (2011), 1152–1159.
- 733 [55] PARNES, A., SOTO, D., ESPARZA, N., GRAVISH, N., WILKINSON, M., AUTUMN,  
734 K., AND CUTKOSKY, M. A microfabricated wedge-shaped adhesive array displaying  
735 gecko-like dynamic adhesion, directionality and long lifetime. *Interface* 6 (2009), 1223–  
736 1232.
- 737 [56] PATIL, S., MANGAL, R., MALASI, A., AND SHARMA, A. Biomimetic wet adhesion  
738 of viscoelastic liquid films anchored on micropatterned elastic substrates. *Langmuir* 28  
739 (2012), 14784–14791.
- 740 [57] PEATTIE, A., AND FULL, R. J. Phylogenetic analysis of the scaling of wet and dry  
741 biological fibrillar adhesives. *Proceedings of the National Academy of Sciences of the*  
742 *United States of America* 104, 47 (2007), 18595–18600.
- 743 [58] PEATTIE, A., MAJIDI, C., CORDER, A., AND FULL, R. J. Ancestrally high elastic  
744 modulus of gecko setal beta-keratin. *Journal of the Royal Society Interface* 4, 17 (2007),  
745 1071–1076.
- 746 [59] PERESSADKO, A., AND GORB, S. When less is more: Experimental evidence for tenac-  
747 ity enhancement by division of contact area. *The Journal of Adhesion* 80, 4 (2004),  
748 247–261.
- 749 [60] PERSSON, B. N. J. On the mechanism of adhesion in biological systems. *The Journal of*  
750 *Chemical Physics* 118, 16 (2003), 7614.
- 751 [61] PERSSON, B. N. J. Biological adhesion for locomotion: basic principles. *Journal of*  
752 *Adhesion Science and Technology* 21, 12-13 (2007), 1145–1173.
- 753 [62] PESIKA, N., TIAN, Y., ZHAO, B., ROSENBERG, K., ZENG, H., MCGUIGGAN, P.,  
754 AUTUMN, K., AND ISRAELACHVILI, J. Peel-zone model of tape peeling based on the  
755 gecko adhesive system. *The Journal of Adhesion* 83 (2007), 383–401.

- 756 [63] RODRÍGUEZ, I., LIM, C., NATARAJAN, S., HO, A., VAN, E. L., ELMOUELHI, N.,  
757 LOW, H., VYAKARNAM, M., AND COOPER, K. Shear adhesion strength of gecko-  
758 inspired tapes on surfaces with variable roughness. *The Journal of Adhesion* 89 (2013),  
759 921–936.
- 760 [64] SAMEOTO, D., AND MENON, C. Recent advances in the fabrication and adhesion testing  
761 of biomimetic dry adhesives. *Smart Materials and Structures* 19 (2010).
- 762 [65] SAMEOTO, D., SHARIF, H., TELLEZ, J., FERGUSON, B., AND MENON, C. Nonangles  
763 anisotropic elastomeric dry adhesives with tailorable normal adhesion strength and high  
764 directionality. *Journal of Adhesion Science and Technology* 28, 3-4 (2014), 354–366.
- 765 [66] SCHARGOTT, M., POPOV, V. L., AND GORB, S. Spring model of biological attachment  
766 pads. *Journal of theoretical biology* 243, 1 (2006), 48–53.
- 767 [67] SHI, X., AND ZHAO, Y. Comparison of various adhesion contact theories and the influ-  
768 ence of dimensionless load parameter. *Journal of Adhesion Science and Technology* 18, 1  
769 (2004), 55–68.
- 770 [68] SPOLENAK, R., GORB, S., GAO, H., AND ARZT, E. Effects of contact shape on the  
771 scaling of biological attachments. *Proceedings of the Royal Society A: Mathematical,*  
772 *Physical and Engineering Sciences* 461, 2054 (2005), 305–319.
- 773 [69] SPUSKANYUK, A., MCMEEKING, R., DESHPANDE, V., AND ARZT, E. The effect of  
774 shape on the adhesion of fibrillar surfaces. *Acta Biomaterialia* 4, 6 (2008), 1669–76.
- 775 [70] TABOR, D. Surface forces and surface interactions. *Journal of Colloid and Interface*  
776 *Science* 58, 1 (1977).
- 777 [71] TAMELIER, J., CHARY, S., AND TURNER, K. Importance of loading and unloading  
778 procedures for gecko-inspired controllable adhesives. *Langmuir* 29 (2013), 10881–10890.
- 779 [72] TAMELIER, J., CHARY, S., AND TURNER, K. L. Vertical anisotropic microfibrils for a  
780 gecko inspired adhesive. *Langmuir* 28 (2012), 8746–8752.

- 781 [73] TANG, T., HUI, C.-Y., AND GLASSMAKER, N. Can a fibrillar interface be stronger  
782 and tougher than a non-fibrillar one? *Journal of the Royal Society Interface* 2 (2005),  
783 505–516.
- 784 [74] TSAI, Y., WU, M., AND SHIH, W. Fabrication and characterisation of e-beam photoresist  
785 array for biomimetic self-cleaning dry adhesives. *Microelectronic Engineering* 88 (2011),  
786 2126–2128.
- 787 [75] VARENBERG, M., MURARASH, B., KLIGERMAN, Y., AND GORB, S. Geometry con-  
788 trolled adhesion: revisiting the contact splitting hypothesis. *Applied Physics A* 103 (2011).
- 789 [76] YANG, F., AND LI, J. Adhesion of a rigid punch to an incompressible elastic film.  
790 *Langmuir* 17 (2001), 6524–6529.
- 791 [77] YU, J., AND BULOVIC, V. Micropatterning metal electrode of organic light emitting  
792 devices using rapid pdms lift-off. *Applied Physics Letters* 91 (2007).
- 793 [78] ZALKOVSKIJ, M., THAMDRUP, L., SMISTRUP, K., ANDEN, T., JOHANSSON, A.,  
794 MIKKELSEN, N., MADSEN, M., GARNAES, J., KRISTIANSEN, T., DIEMER, M.,  
795 DOSSING, M., MINZARI, D., TANG, P., KRISTENSEN, A., TABORYSKI, R., ES-  
796 SENDROP, S., NIELSEN, T., AND BILENBERG, B. Smart plastic functionalization by  
797 nanoimprint and injection molding. *Proc. SPIE 9423 Alternative Lithographic Technolo-*  
798 *gies VII* (2015).
- 799 [79] ZHOU, M., PESIKA, N., ZENG, H., TIAN, Y., AND ISRAELACHVILI, J. Recent ad-  
800 vances in gecko adhesion and friction mechanisms and development of gecko-inspired  
801 dry adhesive systems. *Friction* 1 (2013), 114–129.
- 802 [80] ZHOU, M., PESIKA, N., ZENG, H., WAN, J., ZHANG, X., MENG, Y., WEN, S., AND  
803 TIAN, Y. Design of gecko-inspired fibrillar surfaces with strong attachment and easy-  
804 removal properties: a numerical analysis of peel-zone. *Interface* 9 (2012), 2424–2436.
- 805 [81] ZHOU, M., TIAN, Y., PESIKA, N., ZENG, H., WAN, J., MENG, Y., AND WEN, S. The  
806 extended peel zone model: effect of peeling velocity. *The Journal of Adhesion* 87 (2011),  
807 1045–1058.

## 808 5 Appendix A

### 809 **Rigid cylinder in contact with an elastic half-space**

810 In the case of a flat -ended, rigid cylinder in contact with an elastic half-space (Figure 2 (b)),  
811 the deformation,  $\delta$ , of the elastic half-space when a force,  $F$ , is applied to the cylinder is given  
812 by [36]:

$$\delta = \frac{F(1 - \nu^2)}{2ER} . \quad (28)$$

813 The stored elastic energy,  $U_E$ , is found by rearranging Equation 28 and integrating the force,  
814  $F$ , with respect to deformation,  $\delta$ , giving:

$$U_E = \frac{F^2(1 - \nu^2)}{4ER} + C_E , \quad (29)$$

815 where  $C_E$  is a constant of integration. The surface energy,  $U_S$ , is the product of surface energy  
816 per unit area,  $\gamma$ , and the area of contact. The potential energy of the load,  $U_P$ , is the product of  
817 the force and displacement. The surface and potential energies are given by:

$$U_S = -\pi R^2 \gamma , \quad (30)$$

$$U_P = -\frac{F^2(1 - \nu^2)}{2ER} + C_P , \quad (31)$$

818 where  $C_P$  is a constant of integration. The total energy,  $U_T$ , is the sum of the surface energy,  
819  $U_S$ , and the potential energy of the load,  $U_P$ , given by:

$$U_T = -\pi R^2 \gamma + \frac{(1 - \nu^2) F^2}{4ER} - \frac{(1 - \nu^2) F^2}{2ER} + C_E + C_P = 0 . \quad (32)$$

820 Equilibrium peeling occurs when the differential of total energy across the contacting surfaces

821 (with respect to  $R$ ) is zero, i.e.

$$\frac{dU_T}{dR} = 0 . \quad (33)$$

822 Differentiating Equation 32 according to Equation 33 gives

$$-2\pi R\gamma + \frac{(1 - \nu^2) F^2}{4ER^2} = 0 . \quad (34)$$

823 The adhesive force,  $F$ , can be found by rearranging Equation 34 to give Equation 6, which is  
824 repeated below:

$$F = \sqrt{\frac{E}{(1 - \nu^2)} 8\pi\gamma R^3} ,$$

825 Equation 6 was shown by Kendal to accurately fit experimental data for the separation of acrylic  
826 disks from gelatin sheets for disk diameters ranging from 1–4 cm [36].

## 827 6 Appendix B

### 828 **Thin elastic layer between a rigid cylinder and rigid half-space**

829 For an elastic layer of thickness  $t$  between a rigid cylinder of radius  $R$  and a rigid surface, the  
830 total energy,  $U_T$ , is given by [36]:

$$U_T = -\pi R^2\gamma - \frac{F^2 t}{2\pi R^2} \frac{3(1 - 2\nu)}{E} . \quad (35)$$

831 Applying Equation 33, we get an adhesive force,  $F$ , given by Equation 7, repeated below:

$$F = \sqrt{\frac{2\pi^2\gamma R^4}{t} \frac{E}{3(1 - 2\nu)}} .$$

832 The second term in the energy balance arises from considering the elastic strain according to  
 833 the linear elastic stress-strain relationship. To verify Equation 7, thin sheets of gelatine ranging  
 834 from 400–480  $\mu\text{m}$  in thickness, were sandwiched between an acrylic sheet and acrylic disks  
 835 with diameters ranging from approximately 0.5–4 cm [36].

## 836 7 Appendix C

### 837 **Peeling a thin elastic film from a rigid substrate**

838 For peeling a thin elastic layer of thickness  $t$  and width  $b$  from a rigid substrate, a partially  
 839 separated state is considered in which a distance  $c$  is already peeled. The energy balance for  
 840 creating distance  $\Delta c$  of new surface is then considered (illustrated in Figure 2). Assuming that  
 841 the attached portion of the film is inextensible, the elastic energy,  $U_E$ , in the detached portion  
 842 of the film is given by:

$$U_E = U_B - \frac{F^2 c}{2btE} , \quad (36)$$

843 where  $U_B$  is the elastic energy stored in the sharp bend of the film, and the second term is the  
 844 elastic energy stored in stretching the detached portion of the film. The surface energy,  $U_S$ , is  
 845 given by:

$$U_S = -cb\gamma . \quad (37)$$

846 The potential energy term is the sum of the work done by the force in  $\mathbf{x}$  and in  $\mathbf{y}$ , and can be  
 847 derived by trigonometry. Given that the force is applied at an angle of  $\theta$  to the substrate surface,  
 848 the  $\mathbf{x}$  and  $\mathbf{y}$  components of the force are  $F \cos \theta$  and  $F \sin \theta$ , respectively. The distance travelled  
 849 by the force in  $\mathbf{x}$  and  $\mathbf{y}$  is given by:

$$\Delta x = \Delta c + c \cos \theta - (c + \Delta c) \cos \theta = \Delta c (1 - \cos \theta) , \quad (38)$$

$$\Delta y = (c + \Delta c) \sin \theta - c \sin \theta = \Delta c \sin \theta . \quad (39)$$

850 The work done by the force in propagating the crack a distance  $\Delta c$  is the sum of the work done  
 851 in  $\mathbf{x}$  and  $\mathbf{y}$ , giving:

$$U_P = F \sin \theta \Delta c \sin \theta - F \cos \theta \Delta c (1 - \cos \theta) , \quad (40)$$

$$U_P = F \Delta c (1 - \cos^2 \theta) - F \Delta c (\cos \theta - \cos^2 \theta) , \quad (41)$$

$$U_P = F \Delta c (1 - \cos \theta) . \quad (42)$$

852 It is important to note here that Kendall does not consider the additional movement in the  
 853 applied force owing to elastic extension of the film. However, Kendall states that the elastic  
 854 term can be neglected for most materials, unless stresses up to  $10E$  can be sustained before  
 855 failure, or when the peel angle becomes small.

856 The total energy,  $U_T$ , is then given by:

$$U_T = -cb\gamma + Fc(1 - \cos \theta) + U_B + \frac{F^2 c}{2btE} = 0 . \quad (43)$$

857 From this, the peeling force can be found for three scenarios: (1) considering only surface and  
 858 potential energies,  $F_{surf}$ , (2) considering only elastic and potential energies,  $F_{elastic}$ , and (3)  
 859 considering all energies,  $F_{total}$ , summarised in the following:

$$\frac{\delta U_T}{\delta c} = -b\gamma + F(1 - \cos \theta) + \frac{F^2}{2btE} = 0 , \quad (44)$$

$$F_{surf} = \frac{b\gamma}{1 - \cos \theta} , \quad (45)$$

$$F_{elastic} = b\sqrt{2Et\gamma} , \quad (46)$$

$$0 = \left( \frac{F_{total}}{b} \right)^2 \frac{1}{2tE} + \left( \frac{F_{total}}{b} \right) (1 - \cos \theta) - \gamma . \quad (47)$$

## 860 8 Appendix D

### 861 Contact-splitting theory

862 Starting with the adhesive force from JKR theory [33], we can say that as the substrate radius,  
 863  $R_2$ , approaches infinity (i.e. essentially a flat substrate),  $R^*$  becomes the radius of the top  
 864 sphere,  $R_1$ , which we will now refer to as  $R_0$ . The adhesive force,  $F_0$ , for a single spherical  
 865 contact is then given by:

$$F_0 = \frac{3}{2}\gamma\pi R_0 . \quad (48)$$

866 If we divide the contact into an array of  $n$  contacts with radius,  $R$ , given by:

$$R = \frac{R_0}{\sqrt{n}} , \quad (49)$$

867 so that the contact area of the array,  $n\pi R^2$ , is equal to that of the single contact,  $\pi R_0^2$ . The  
 868 adhesive force,  $F$ , for a contact is given by:

$$F = \frac{3}{2}\gamma\pi \left( \frac{R_0}{\sqrt{n}} \right) , \quad (50)$$

$$F = \frac{1}{\sqrt{n}}F_0 . \quad (51)$$

869 The total adhesive force for the array of spheres,  $F_T$ , can be found by summing over  $n$  to  
 870 give:

$$F_T = \frac{n}{\sqrt{n}} F_0 , \quad (52)$$

871 which is identical to Equation 13, repeated below:

$$F_T = \sqrt{n} F_0 .$$

## 872 9 Appendix E

873 Contact-splitting theory can be used to estimate how the adhesive force ratio varies with the  
 874 geometric parameters of areal density,  $\rho$ , geometric area,  $A$ , and fibre radius,  $R$  [68]. The  
 875 number of pillars in the array,  $n$ , is given by:

$$n = \frac{\rho R_0^2}{r^2} . \quad (53)$$

876 For a spherically terminated pillar with self-similar scaling the total force scales with  $\sqrt{n}$ ,  
 877 giving the following adhesive force ratio:

$$\frac{F_T}{F_0} = \rho \sqrt{n} , \quad (54)$$

$$\frac{F_T}{F_0} = \rho^{\frac{3}{2}} R_0 r^{-1} . \quad (55)$$

878 Similarly, for curvature invariance the total force scales linearly with  $n$ , giving:

$$\frac{F_T}{F_0} = \rho n , \quad (56)$$

$$\frac{F_T}{F_0} = \rho^2 R_0^2 r^{-2} . \quad (57)$$

879 For a flat-ended, rigid punch we recall that the force scales with  $n^{0.25}$ , which gives:

$$\frac{F_T}{F_0} = \rho n^{\frac{1}{4}} , \quad (58)$$

$$\frac{F_T}{F_0} = \rho \left( \frac{\rho R_0^2}{r^2} \right)^{\frac{1}{4}} , \quad (59)$$

$$\frac{F_T}{F_0} = \rho^{\frac{5}{4}} R_0^{0.5} r^{-0.5} . \quad (60)$$