



**URBAN ROAD TRANSPORT EMISSIONS AND POTENTIAL
FOR REDUCING EMISSIONS BY ELECTRIC VEHICLES
CASE STUDY OF SINGAPORE**

DWIYANTI ARIMBI JINCA

INTERDISCIPLINARY GRADUATE PROGRAMME (IGP)

2021

**URBAN ROAD TRANSPORT EMISSIONS AND POTENTIAL
FOR REDUCING EMISSIONS BY ELECTRIC VEHICLES
CASE STUDY OF SINGAPORE**

DWIYANTI ARIMBI JINCA

Interdisciplinary Graduate Programme (IGP)

A thesis submitted to the Nanyang Technological University in partial
fulfilment of the requirement for the degree of Doctor of Philosophy

2021

Acknowledgements

Alhamdulillah, all praise and glory to Allah for his blessings of strength and patience in completing this dissertation.

I would like to offer my sincere gratitude to TUM CREATE in Singapore for allowing me to conduct this research as a Research Associate where I could be a part of this incredible endeavour gaining access to the Institution's research network. This research was funded by the Singapore National Research Foundation (NRF) under its Campus for Research Excellence and Technological Enterprise (CREATE) programme.

My appreciation and gratefulness go further to my supervisors. Firstly, I would like to thank Prof. Gebhard Wulforst for allowing me to write this dissertation under his supervision at the Technical University Munich (TUM) Germany. I sincerely appreciated his encouragement, feedback, and the freedom he gave me throughout the years to elaborate on this topic. Secondly, I would like to thank Associate Prof. Wong Yiik Diew at the Nanyang Technological University (NTU) Singapore for his support, guidance, and taking over Prof. Victor Chang's co-supervisor role at NTU. Thirdly, I owe Prof. Chang thanks for his invaluable assistance at the beginning of my research.

I would like to extend my gratitude to Dr. Andreas Rau as a Principal Investigator at RP10/RRT for his guidance in the research field and generous support through the years of my stay at TUM CREATE. I also wish to thank his team for its amazing collaboration, discussion, and feedback during my stay in Singapore.

I want to thank the Land Transport Authority (LTA) for its co-project with NTU-Centre for Infrastructure System (CIS), which gave me excellent experience in air quality measurements and access to tunnel data. I would also like to thank the technical team at the NTU-CIS, the transportation and environment laboratories at NTU for providing valuable discussion, research instruments and other aids.

Dear friends I have made in Singapore and Germany, please know that your support and encouragement were worth more than I can express. Lea, thank you very much for your contribution and motivation at the last minute in concluding this dissertation.

Finally, I would like to extend my thanks to my parents and brothers. Especially Mother, my first love, thank you for your unconditional support, affection, and endless prayers for my success. Special thanks to my husband Mic, my sons Salomon and Noah for coming into my life during the research period and for their patience, encouragement, and eternal love.

Statement of Originality

I hereby certify that the work embodied in this thesis is the result of original research, is free of plagiarised materials, and has not been submitted for a higher degree to any other University or Institution.

15.06.2023

ITU NTU NTU NTU NTU NTU NTU NTU NTU
NTU NTU NTU NTU NTU NTU NTU NTU NTU NTU
ITU NTU NTU NTU NTU NTU NTU NTU NTU NTU
ITU NTU NTU NTU NTU NTU NTU NTU NTU

Dwiyanti Arimbi Jinca

Supervisor Declaration Statement

I have reviewed the content and presentation style of this thesis and declare it is free of plagiarism and of sufficient grammatical clarity to be examined. To the best of my knowledge, the research and writing are those of the candidate except as acknowledged in the Author Attribution Statement. I confirm that the investigations were conducted in accord with the ethics policies and integrity standards of Nanyang Technological University and that the research data are presented honestly and without prejudice.

30.06.2023

NTU NTU NTU NTU NTU NTU NTU NTU
NTU NTU NTU NTU NTU NTU NTU NTU
NTU NTU NTU NTU NTU NTU NTU NTU
NTU NTU NTU NTU NTU NTU NTU NTU

Assoc Prof Wong Yiik Diew

Authorship Attribution Statement

This thesis does not contain any materials from papers published in peer-reviewed journals or from papers accepted at conferences in which I am listed as an author.

15.06.2023

ITU NTU NTU NTU NTU NTU NTU NTU
NTU NTU NTU NTU NTU NTU NTU NTU
ITU NTU NTU NTU NTU NTU NTU NTU
ITU NTU NTU NTU NTU NTU NTU NTU
Dwiyanti Arimbi Jinca

Table of Contents

Acknowledgements	I
Statement of Originality	III
Supervisor Declaration Statement	V
Table of Contents	V
List of Figures	IX
List of Tables	XIII
Abstract	XV
1 Introduction	1
1.1 Background	1
1.1.1 The international context	1
1.1.2 The Singapore context	4
1.1.3 Current gap	7
1.2 Research questions and research objective	8
1.3 Scope and research design	8
1.4 Chapters at a glance	10
2 Vehicle Emissions from Road Transport	13
2.1 Pollutants emitted by motor vehicles	13
2.1.1 Carbon dioxide (CO ₂)	14
2.1.2 Carbon monoxide (CO)	14
2.1.3 Hydrocarbons (HCs) and volatile organic compounds (VOCs)	14
2.1.4 Particulate matter (PM)	15
2.1.5 Nitrogen oxides (NO _x)	15
2.2 Factors influencing motor vehicle emissions	16
2.3 Regulating vehicle emission standards	17
2.4 Vehicle emissions measurements	19
2.4.1 Emission measurement under the controlled conditions	20
2.4.2 Emission measurement in real-world conditions	21
2.4.3 Advantages and disadvantages of real-world and under-controlled conditions	24
2.5 Emission factors (EFs) development	24
2.6 State of the art of emissions models	24
2.6.1 Classification of emissions models	25
2.6.2 Overview of the selected emissions models	26

3	Vehicle Emissions Model Selection	39
3.1	Introduction	39
3.2	Criteria influencing emissions model selection	39
3.2.1	Internal criteria	40
3.2.2	External criteria	50
3.3	The proposed process of selecting a suitable emissions model	51
3.4	Case of Singapore	53
3.5	Conclusions	54
4	Vehicle Fleet in Singapore	57
4.1	Introduction	57
4.2	Methodology	58
4.3	Primary information for the vehicle fleet model	59
4.4	Vehicle fleet classification	62
4.4.1	Vehicle fleet by fuel/technology	62
4.4.2	Vehicle fleet by engine capacity/maximum laden weight	64
4.4.3	Vehicle fleet by age	67
4.4.4	Vehicle fleet by Euro emission standards	70
4.4.5	Fleet development per vehicle sub-segment/classification	72
4.5	Local transport characteristics	73
4.5.1	Vehicle ownership	73
4.5.2	Vehicle kilometre travelled (VKT)	74
4.5.3	Average speed	77
4.5.4	Road vehicle transport performance	78
4.6	Summary	79
5	Application of an emissions model at a city-state scale in Singapore	81
5.1	Introduction	81
5.2	Objective	81
5.3	Emission calculation steps	82
5.3.1	Boundary	82
5.3.2	Methodology	82
5.3.3	Data collection and analysis	84
5.5	Results and discussion	87
5.6	Limitations	91
5.7	Conclusion	93

6	Determination of Average Emission Factor based on the Tunnel and Open Road Measurements	95
6.1	Tunnel measurement	95
6.1.1	Tunnel and its characteristics	95
6.1.1.1	Tunnel studies for EFs development	96
6.1.1.2	KPE tunnel	97
6.1.2	Experimental tunnel measurement	99
6.1.2.1	Principle and methodology	99
6.1.2.2	Measurement program	100
6.1.2.3	Location and equipment	101
6.1.2.4	Sampling and data analysis	103
6.1.3	Preliminary results	103
6.1.3.1	Observed traffic data	103
6.1.3.2	Tunnel environment conditions and pollutants concentrations	108
6.1.3.3	The relationship between traffic flow and pollutants concentration	109
6.1.4	EFs estimation	110
6.1.4.1	Dependence of EFs on speed	110
6.1.4.2	Calculated EFs of CO and NO	110
6.1.4.3	EFs comparison with previous tunnel studies	111
6.1.4.4	Comparison of determined EFs with EFs models	112
6.2	Open road measurement	113
6.2.1	Open road measurement and its characteristics	113
6.2.2	Principle and methodology	114
6.2.3	Experimental open road measurement	115
6.2.3.1	Field experiment	115
6.2.3.2	Monitoring the air quality and traffic condition	115
6.2.4	Results	119
6.2.5	Lessons learned	122
6.3	Limitation	123
6.4	Conclusion	124
7	Potential Emissions Reduction by Introduction of Electric Vehicles	127
7.1	Introduction	127
7.2	The Singapore EVs, energy and policies outlook	129
7.2.1	EVs in Singapore	129

7.2.2	Number of electric cars in Singapore	131
7.2.3	Singapore's energy outlook, transport outlook and related policies	131
7.3	Framework development	132
7.3.1	Background fleet and emission information	133
7.3.2	Scenario, variables and responses	133
7.3.3	Intermediate result of the vehicle fleet	138
7.4	Results and discussion	142
7.4.1	Scenario Analysis	143
7.4.2	Potential emissions reduction analysis	147
7.5	Limitation	148
7.6	Conclusion	149
8	Findings, Conclusion and Recommendation	151
8.1	Summary	151
8.2	Findings	153
8.3	Conclusion	156
8.4	Recommendations for further research	159
9	Publication bibliography	161
	Acronyms and abbreviations	177
	Appendix	181

List of Figures

Figure 1-1: Land transport emissions by mode in Singapore 2005 (LTA 2011)	5
Figure 2-1: Emission standards for Singapore passenger cars	19
Figure 2-2: Schematic of a chassis-dynamometer emissions test facility (Franco et al. 2013)	20
Figure 2-3: Chassis vs engine dynamometer where the emissions are expressed in g/kWh (Hallsten 2009)	21
Figure 2-4: Passenger car instrumented with PEMS (Franco et al. 2013)	22
Figure 2-5: The emission estimation process in MOVES (Huang and Hu 2018; Vallamsundar and Lin 2011)	28
Figure 2-6: Illustration of the emission rate for each combination (EPA US 2011)	30
Figure 2-7: HBEFA methodological approach in generating EFs (Schmied 2014)	34
Figure 2-8: Average speed emission function for NO _x emission from Euro 3 diesel cars <2.0 litres (Barlow and Boulter 2009)	35
Figure 2-9: Model structure of PHEM (Hausberger et al. 2005)	37
Figure 3-1: Typical transport emissions model application based on the desired objectives	42
Figure 3-2: Emissions model approaches based on the scale required for modelling application purposes	48
Figure 3-3: The proposed analytical process for the selection criteria of a suitable emissions model	52
Figure 4-1: Vehicle population data availability by sub-segments	59
Figure 4-2: Vehicle population, fleet composition and its annual growth rate	61
Figure 4-3: Vehicle share by categorisation	61
Figure 4-4: PCs and taxis share by fuel/technology	62
Figure 4-5: LDVs and HDVs share by fuel/technology	63
Figure 4-6: Public bus and coach population by fuel/technology	64
Figure 4-7: PCs share by engine size (Singapore fleet categorisation)	66
Figure 4-8: MCs share by engine size (Singapore fleet categorisation)	66
Figure 4-9: Goods and other vehicles share by maximum laden weight (Singapore fleet categorisation)	66
Figure 4-10: Average age of PCs between 2003-2019	67
Figure 4-11: PCs age share and average vehicle age 2004-2019 (analysed from LTA data)	68
Figure 4-12: MCs age share and average vehicle age 2004-2019 (analysed from LTA data)	69
Figure 4-13: LCVs & LDVs age share and average vehicle age 2004-2019 (analysed from LTA data)	69
Figure 4-14: Buses age share and average vehicle age 2004-2019 (analysed from LTA data)	70

Figure 4-15: Penetration of emission concepts in petrol PC	70
Figure 4-16: Emission standards development for PCs-gasoline and PCs-diesel, 2004-2019	71
Figure 4-17: Emission standards development for diesel vehicles, 2004-2019	72
Figure 4-18: Development of PCs-petrol stock per sub-segment	73
Figure 4-19: PC ownership (analysed from LTA data)	73
Figure 4-20: Car ownership (Boey and Su 2014)	74
Figure 4-21: Share of vehicle population and VKT in 2015 and 2019 (analysed from LTA data)	75
Figure 4-22: Annual average VKT of a taxi, public bus, PC and MC	75
Figure 4-23: Annual average VKT of vehicles	76
Figure 4-24: Annual VKT in developed countries (ACEA 2019; Odyssee-mure 2021; FHWA 2018)	76
Figure 4-25: Vehicle speed vs vehicle population (adopted from (LTA 2015))	77
Figure 4-26: Development of fleet mileage proportion in the period of 2004-2019	79
Figure 5-1: System boundaries of emission calculation for Singapore (Duennelbeil et al. 2012).	82
Figure 5-2: Emissions inventory model structure	84
Figure 5-3: Temperature in Singapore	85
Figure 5-4: Road transport sector fuel consumption	86
Figure 5-5: Singapore's emission trends by vehicle category	88
Figure 5-6: Singapore's road transport CO ₂ emissions based on a top-down approach (2004–2011)	90
Figure 5-7: Studies comparison of road transport CO ₂ emissions by vehicle type in 2010	91
Figure 6-1: Map of Expressways in Singapore (OpenStreetMap, 2018)	97
Figure 6-2: Pollutant mass balances principle from tunnel experiments (Fredrich and Reis 2014)	99
Figure 6-3: Location of the measurement (adopted from LTA-NTU study)	102
Figure 6-4: Tunnel layout (Kwa 2010)	102
Figure 6-5: Typical traffic flow between 5.35 and 6.6 km at the KPE tunnel	104
Figure 6-6: Weekday and weekend traffic flow and its vehicle distribution based on CCTV footage inside the KPE tunnel	105
Figure 6-7: Weekday traffic flow and its vehicle distribution based on video recording near the KPE tunnel exit and entrance	106
Figure 6-8: Weekend traffic flow and its vehicle distribution based on video recording near the KPE tunnel exit and entrance	106

Figure 6-9: Comparison of vehicle distribution using two different approaches (CCTV and video recording)	107
Figure 6-10: Comparison of the national population and KPE tunnel vehicle distribution	107
Figure 6-11: The diurnal variation of CO concentrations during weekday and weekend	108
Figure 6-12: The diurnal variation of NO concentrations during weekday and weekend	109
Figure 6-13: The relationship between CO concentrations and traffic flows on the weekend and weekdays	110
Figure 6-14: The relationship between NO concentrations and traffic flows on the weekend and weekdays	110
Figure 6-15: Principle of pollutant mass balances from an open road experiment (Fredrich and Reis 2014)	114
Figure 6-16: Location of open road measurement at AYE – Clementi Sports Hall, at the pedestrian bridge (left) and AYE – Pandan Garden, at non-motorised transport (NMT) bridge	117
Figure 6-17: Location of the experiment at Nicoll Highway, at the roadside, green area near footpath (left) and Bt Batok East Ave 5, at the roadside, green area near footpath (right)	117
Figure 6-18: Location (4), box 1: air quality monitoring instrument (wind tracker, particle counters, and multi-gas detector)	118
Figure 6-19: Location (4), box 1 (left) and box 2 (right)	118
Figure 6-20: Location (4), box 3 (left), video recording at box 3 (right)	118
Figure 6-21: Measured CO concentrations at Bukit Batok Str. 52	120
Figure 6-22: Measured NO _x concentrations at Bukit Batok Str.52	121
Figure 6-23: Measured PM _{2.5} and PM ₁₀ concentrations at Bukit Batok Str.52	121
Figure 7-1: Electric PCs and PHCs development in Singapore	131
Figure 7-2: Electric taxis development in Singapore	131
Figure 7-3: Limited electricity generation in Singapore (Energy Market Authority 2017a)	132
Figure 7-4: Historical and projected vehicle population - BaU scenario	134
Figure 7-5: Historical and projected VKT – BaU scenario	134
Figure 7-6: Historical and projected EVs share of PC and PHC – BaU scenario	135
Figure 7-7: Historical and projected vehicles population - Scenario 3	137
Figure 7-8: Projection of vehicles under different scenarios	139
Figure 7-9: Vehicles number in the past and projection in four scenarios	139
Figure 7-10: PC and PHC share in past years and the scenarios	140
Figure 7-11: MC share in past years and scenarios	140
Figure 7-12: Taxi share in past years and the scenarios	140

Figure 7-13: Public bus share in past years and the scenarios	141
Figure 7-14: Coaches share in past years and the scenarios	141
Figure 7-15: LDV share in past years and the scenarios	141
Figure 7-16: HDV share in past years and the scenarios	142
Figure 7-17: Air pollutants and CO ₂ emission projections trend in the four scenarios	142
Figure 7-18: Comparison of overall CO in the four scenarios	143
Figure 7-19: CO comparison per vehicle type in the four scenarios	143
Figure 7-20: Comparison of overall NO _x in the four scenarios	144
Figure 7-21: NO _x comparison per vehicle type in the four scenarios	144
Figure 7-22: Comparison of overall PM _{2.5} and PM ₁₀ in the four scenarios	145
Figure 7-23: PM _{2.5} comparison per vehicle type in the four scenarios	145
Figure 7-24: PM ₁₀ comparison per vehicle type in the four scenarios	145
Figure 7-25: Comparison of overall PM ₁₀ in the four scenarios	146
Figure 7-26: VOC comparison per vehicle type in the four scenarios	146
Figure 7-27: Comparison of overall CO ₂ in the four scenarios	147
Figure 7-28: CO ₂ comparison per vehicle type in the four scenarios	147
Figure 7-29: Emissions reduction potentials under the S1, S2, and S3 compared to BaU	148
Figure 7-30: CO ₂ reduction potentials under the S1, S2, and S3 compared to BaU	148

List of Tables

Table 1-1: Proposed research boundary	9
Table 2-1: Factors influencing road vehicle emissions (Franco et al. 2013; Duennelbeil et al. 2012; Spence et al. 2009; Atjay 2005; Smit et al. 2009; Chiang et al. 2007)	16
Table 2-2: Changes in performance standards for petrol-driven passenger cars and LDVs (in gramme/km) (Dieselnet 2021; Continental 2019)	18
Table 2-3: Summary of pollutants measured in the tunnel and the associated methods	22
Table 2-4: Advantages and disadvantages of under-controlled and real-world conditions	24
Table 2-5: Overview of the emissions models in Europe and the US	26
Table 2-6: Overview of selected emissions models	27
Table 2-7: MOVES overview (summarised from (EPA US 2018a, 2018b; US EPA 2015; U.S. EPA 2021))	29
Table 2-8: EMFAC overview (Bai et al. 2008; CARB 2021)	31
Table 2-9: HBEFA overview (Notter et al. 2019; Smit et al. 2014)	32
Table 2-10: Different models for different vehicle categories are used to produce EFs in HBEFA	33
Table 2-11: COPERT overview (Smit et al. 2014)	36
Table 2-12: PHEM overview (Hausberger 2017; Hausberger et al. 2003b)	38
Table 3-1: Identification of the selection criteria for emission modelling	40
Table 3-2: Pollutants effects caused by transport activities (Hickman et al. 2009)	43
Table 3-3: Emissions model classification	44
Table 3-4: Data requirement of emission modelling approaches	49
Table 3-5: Data available for Singapore	54
Table 4-1: Input data, quality, and their respective sources	57
Table 4-2: Motor vehicle categorisation and its assumption	60
Table 4-3: Summary of vehicle type/technology/fuel combinations in Singapore	62
Table 4-4: Engine capacity categorisation of PC	64
Table 4-5: Engine capacity categorisation of MC	65
Table 4-6: Maximum laden weight categorisation of LDV and HDV	65
Table 4-7: The lifespan of vehicles (OneMonitoring 2021)	67
Table 4-8: Speed limit on different road types (AGC 2021)	77
Table 4-9: Summary of Singapore fleet and its activities	80
Table 5-1: Road transport sector fuel	86
Table 5-2: CO ₂ conversion factor adopted from IPCC	86

Table 5-3: Top-down vs bottom-up CO ₂ emissions estimation	90
Table 5-4: Bottom-up vs another CO ₂ emissions estimation	91
Table 6-1: Advantages and disadvantages of traffic tunnel studies (Corsmeier et al. 2005)	96
Table 6-2: KPE tunnel characteristics (Jiangxun 2010; Yang 2014; Ming 2009; Meng et al. 2011; LTA 2014a))	98
Table 6-3: Jet fans operation conditions (adopted from LTA-NTU study)	98
Table 6-4: Measurements of KPE tunnel study, case area: the Southbound bore of the KPE tunnel	101
Table 6-5: Concentrations and calculated EFs of CO and NO in the KPE tunnel	111
Table 6-6: Comparison of pollutants EFs in g/km-veh. with other tunnel studies	112
Table 6-7: Comparison of determined EFs with EFs from COPERT model	113
Table 6-8: Advantages and disadvantages of EFs assessment at open road study	114
Table 6-9: Air quality monitoring, meteorological and traffic survey equipment	116
Table 6-10: Equipment boxes	116
Table 6-11: Selected air quality monitoring and traffic data points in the field	119
Table 6-12: Determined EFs based on open road measurements	122
Table 7-1: Singapore's policies that support the penetration of EVs (summarised from literature (APEC 2017; LTA 2010))	130
Table 7-2: Historical and projected EVs share in BaU scenario	135
Table 7-3: Growth rate projection in BaU scenario	136
Table 7-4: Historical and projected EVs share in S1 scenario	136
Table 7-5: Historical and projected EVs share in S2 scenario	137
Table 7-6: Historical and projected EV share in S3 scenario	138

Abstract

Road transport is one of the fastest-growing sectors contributing significantly to air pollution and greenhouse gas (GHG) emissions, especially in urban areas where exceedances of nitrogen oxides (NO_x) and particulate matters (PM) values are frequent. These pollutants have clear health implications and indicate the need to plan and implement effective measures (such as introducing electric vehicles) to reduce road vehicles' emissions. Emissions estimation from road transport could be applied using an emissions model. However, the emissions model reflecting Singapore's local conditions is not yet available, and there are only limited emissions quantification efforts over the last few decades in Singapore.

This research aims to analyse how and to what extent the existing emissions models apply to Singapore's urban area emissions estimation. This aim is accompanied by vehicle fleet development and emissions inventory estimation for 2004-2019, the identification of aggregated emission factors (EFs) from air quality measurements at the Kallang Paya-Lebar (KPE) tunnel expressway and estimation of potential emissions reduction of electric vehicles (EV) scenario (up to 2050).

The emissions loads for all pollutants showed a decreasing trend from 2004-2019. This result comes from the series of transportation policies such as vehicle growth control by way of vehicle quota system (VQS) and vehicle ownership in terms of the certificate of entitlement (COE) (which results in a high turnover rate of vehicles) and a combination of fiscal measures (e.g., vehicle taxes). A clear reduction trend was found for pollutants of carbon monoxide (CO) and volatile organic compounds (VOC), with passenger cars (PCs) and motorcycles (MCs) being the primary sources. Meanwhile, NO_x, PM₁₀ and PM_{2.5} emissions, which are mainly released by diesel vehicles, gradually decreased despite increasing the vehicle population using diesel and its transport activities. A comparison of bottom-up and top-down carbon dioxide (CO₂) estimations showed less agreement, with a difference of 20% due to some limitations. The methodology, results and conclusions may apply to neighbouring cities in South-East Asia.

The aggregated EF was derived from the Kallang-Paya Lebar (KPE) tunnel measurement in 2015 showed CO=1.46 g/veh-km and NO_x=0.28 g/veh-km. These values are compared to previous studies performed in other tunnels globally. It was evident that both CO and NO_x EFs are at a low-level range. Still, some parts need to be improved in future EFs development in a tunnel and other real-world measurements.

Potential air pollutants and emissions reduction by penetration of electric vehicles (EVs) are estimated using COPERT emissions model under four scenarios; baseline, the basic scenario (S1), the medium scenario (S2) and the most ambitious scenarios (S3). Significant emissions reduction potential for 2050 is identified in scenario 3, with a reduction of 83%, 96%, and 85% in

CO, VOC and CO₂. NO_x reduction is estimated at 66%, while for PM, the reduction is predicted to have less reduction (<50%) due to the still high share of non-exhaust emissions. The results provide a basis and support for additional policies to promote and manage EVs. Besides, insights into improving air quality are offered to support the global climate change issue.

1 Introduction

Air pollution is increasingly widespread concern of local governments, citizens, and other stakeholders worldwide. A significant public health crisis is arising from poor air quality, with around 6.5 million premature deaths estimated each year (IEA 2016). At the same time, climate change is also an urgent global problem. Worldwide, around 55% of the population lives in urban areas, which account for 80% of global economic activities. Therefore, urban areas are often claimed to be responsible for the rapid growth of global energy use and energy-related greenhouse gas (GHG) emissions (UN 2014).

According to (IEA 2017b), the transportation sector contributed nearly 23% of global energy-related GHG emissions in 2015, with road transport accounting for the vast majority of those emissions. In urban areas, the road transport sector is the foremost contributor to air pollution (IEA 2017a). The transport sector's impact on the environment will continue to increase unless drastic actions are undertaken to address these fossil energy use issues with significant attention and commitment. Therefore, quantifying the air pollution, energy consumption, and carbon emissions produced by transport is essential for effective policy formulation, management of energy resources, and better local air quality and climate environment.

1.1 Background

1.1.1 The international context

The transport sector is among the fastest-growing contributors to carbon dioxide (CO₂) emissions. Its global emissions accounted for one-fifth of overall emissions in 2016, with approximately 8 Gt CO₂ or 71% more than in 1990. The highest share of CO₂ emissions was in road transport, at 74% in 2016 (IEA 2018). Without any strategic intervention, the global CO₂ emissions are predicted to increase under “Business as Usual (BaU)”. This trend will continue due to economic activities, the rapid development of motorisation and urbanisation. Consequently, the problems of energy consumption, transport emissions, and traffic congestion are becoming more prominent.

As a critical cause of GHG emissions, the transportation sector is also responsible for a significant portion of urban air pollution. In 2012, the World Health Organisation (WHO 2015) reported that ambient air pollution accounted for 3.7 million premature deaths. The transport sector contributed for around half of all nitrogen oxide (NO_x) emissions of other pollutants in 2017 (EEA 2017). Besides that, this sector produced around 11.4% of total global ambient primary particulate matter (PM_{2.5}) and ozone deaths in 2015 (Anenberg et. al 2019). According to (IEA 2016), road transport was the largest source of the sector's NO_x and primary PM_{2.5} emissions (58% and 73% of the total). Moreover, heavy-duty vehicles (HDVs) contributed to

over 40% of NO_x and more than 50% of PM_{2.5} emissions. The growing number of motor vehicles and their activities are primary sources of air pollution, resulting in the concentration of pollutants in urban areas.

Combustion of fossil energy (crude oil, natural gas) leads to climate change and air pollution. Incomplete fuel combustion produces unburnt hydrocarbons (UHCs) and other volatile organic compounds (VOC_s), carbon monoxide (CO), and PM. Sulphur dioxide (SO₂) and NO_x are mostly products of diesel fuel combustion. These pollutants directly and indirectly impact human health. The complete combustion of fuel molecules produces CO₂, which contributes to climate change.

More attention is being given to environmental management throughout the world, including air pollution and climate change. International, regional and national agreements and legislation have been created to overcome this problem. These include the United States (US) Clean Air Act in 1970 and its amendment, the Geneva Convention on Long-range Transboundary Air Pollution (CLRTAP) in 1979, the United Nations Framework Convention on Climate Change (UNFCCC) in 1992, the Kyoto Protocol (1997), the Copenhagen Accord (2009), and the Paris Agreement (2015). Several guidelines are in place to improve air quality and climates, such as the Intergovernmental Panel on Climate Change (IPCC) Guidelines for National Greenhouse Gas Inventories and Air Quality Guidelines for Europe.

The frameworks mentioned above brought together different stakeholders to set methodologies and programmes related to emissions estimation and their reductions, including:

- Methodology for Calculating Transport Emissions and Energy Consumption (MEET), 1996-1999. The aim was to provide an essential procedure for evaluating the impact of transport on air pollution Europe-wide (TRIP).
- The European Monitoring and Evaluation Programme (EMEP¹). This systematic policy-driven programme under the CLRTAP for international co-operation aims to solve transboundary air pollution problems. One of the first results was the EMEP/CORINAIR atmospheric emission inventory guidebook in 1996, and the latest one is EMEP/EEA² air pollutant emission inventory guidebook in 2016 (EEA 2016a).
- The European Commission 5th Framework project ARTEMIS (Assessment of Transport Emission Modelling and Inventory Systems). The project was developed to harmonise

¹ EMEP is a co-operative programme for monitoring and evaluation of the long-range transmission of air pollutants in Europe. This scientifically based and policy driven programme falls under the UNECE Convention on Long-range Transboundary Air Pollution. <http://www.emep.int/>.

² EEA is a European Environment Agency of the European Union. It is an independent information source about the environment for those involved in developing, adopting, implementing and evaluating environmental policy, and the general public. <http://www.eea.europa.eu/>

the emissions models for all transport sectors and provide consistent emissions estimation at national, regional and international levels (Boulter and Mccrae 2007a).

Increasing concern about air pollutants and GHG emissions (e.g., CO₂) and their impact motivate diverse stakeholders to develop a broad-based approach to estimating direct and indirect impacts of road traffic activities. Various vehicle emissions measurements and modelling have been elaborated in the last few decades by diverse groups to understand transport activities' direct and indirect impacts. However, most vehicle emissions models are developed and applied in Europe and North America, reflecting their vehicle fleet, driving behaviour, and other characteristics. Still, the demand for emissions estimation is continuously growing in other parts of the world. There is no international agreement on the specific emission models that are best for various situations and applications (Smit et al. 2007; Smit et al. 2009). Moreover, emissions estimation results can vary significantly depending on the methodology chosen (Duduta, Bishins 2010).

Electric mobility or electromobility is often claimed as one of the key drivers toward greener future mobility. Electromobility relates to the electrification of the automotive powertrain, and in this dissertation, the researcher refers to electric vehicles (EVs). EVs are road vehicles that use an electric motor as the primary propulsion source (Lie et al. 2017). These vehicles typically refer also to battery electric vehicles (BEVs). Other types of EVs are described later (Chapter 7). As one alternative transport method to an internal combustion engine (ICE) vehicle, EVs offer the advantages of zero tailpipe emissions, noiseless operation, and a reduction of oil dependence. Particularly in urban areas, EVs can improve air quality and increase the urban's quality of life.

To overcome the transport-related emission problem, worldwide governments are implementing ambitious policies and incentives to promote EVs and phase out ICE vehicles. As a result, since 2013, there has been a rapid growth in EVs stock worldwide. According to (IEA 2020), the EVs volume increased from 0.35 million in 2013 to 7.2 million at the end of 2019, with China contributed 47% of this increase. Norway had the highest total EVs share in the fleet with 13%, followed by Iceland (4.4%), the Netherlands (2.7%), Sweden (2%) and China (1.6%). Although EVs current market is still relatively small, at just around 2.6% of the global car stock, the future will bring a massive shift to EVs.

As a reducing factor of CO₂ emissions in the road transport sector, EVs were investigated and researched extensively in different study cases. Most of these cases covered the GHG life cycle assessment (LCA) analysis, such as a case in the United Kingdom (UK) and California (Ma et al. 2012) or the well-to-wheels (WtW) analyses in Ireland (Smith 2010), Korea (Seo et al. 2018),

China (Hofmann et al. 2016) and Brazil (Choma and Ugaya 2017). The significantly different proportions of EVs penetration among the different studies were due to variances in factors such as fleet scenarios, urban cycles, and speed. However, most of the studies agreed that the CO₂ emissions reduction from EVs is apparent, with the degree depending on the primary electricity source. Further detailed analysis of previous related studies is discussed later (Chapter 7).

1.1.2 The Singapore context

Singapore is a unique island city-state located in South-East Asia with a land area of only 719 km² and about 5.6 million inhabitants in 2018 (Singapore in Figures 2019). The state is considered a tropical country due to its location close to the equator line. Temperature and high humidity are typically uniform throughout the year. The daily temperature ranges from 23°C - 32°C, while the average humidity of 84% (Meteorological Service Singapore 2018).

In 2015, Singapore contributed about 0.11% of global CO₂ emissions. However, in terms of CO₂ emissions per capita, the country is ranked 26th out of 142 countries due to its small size and high density (NCCS 2016). In 2012, the transport sector contributed to the third-largest share of energy consumption after the power and industry sectors. Transport was estimated at 13% of national energy consumption and around 15% of total CO₂ emissions (NEA 2014). Although China and India have constituted the largest share of CO₂ total emissions in road transport in Asia, Malaysia and Singapore have had the highest per capita CO₂ emissions (Clean Air Asia 2012). Nevertheless, Malaysia and Singapore's road transport per capita emissions are much lower than the average Organisation for Economic Co-operation and Development (OECD) countries' per capita emissions.

Despite the emissions facts mentioned above, Singapore is actively involved in the international climate change negotiation. In 2009, Singapore embarked on policies and measures with a potential reduction of 7%-11% below the BaU level by 2020 (National Climate Change Secretariat 2012). Moreover, Singapore pledged to undertake mitigation measures leading to a reduction of GHG emissions by 16% below the 2020 BaU level, contingent on a legally binding global agreement, in which all countries implement their commitments respectively. Furthermore, Singapore submitted its Intended Nationally Determined Contribution (INDC) to the UNFCCC in 2015 and signed the Paris Agreement in 2016. Singapore's INDC highlights its initiatives to minimise emissions intensity by **36% by 2030 compared to 2005** levels. Singapore intends to target 65Mt CO₂e around 2030 to meet emissions intensity targets (Allan and J. Tao 2015).

The transport sector has a vital role to play in achieving those emissions reduction targets. Consequently, Singapore should establish a national inventory of GHG emissions and related air pollutants released by anthropogenic activities, including road transport, to understand the magnitude of its transport activities. The emission inventory is an essential tool for forecasting traffic emissions trends and laying out strategies and policies to achieve sustainable targets.

Around 970,000 motor vehicles were registered in 2019 (LTA 2019a), which means Singapore has one of the lowest motor vehicles per population level among the developed countries. In 2019, petrol was the primary fuel type used for passenger cars with a share of 91% and motorcycles with close to 100%. On the other hand, diesel as a fuel type is used mainly by taxis (53%), buses (99.6%), goods and other vehicles (96.3%). Overall, the fuel consumption trend of total vehicles is dominated by diesel due to the higher number of kilometres travelled by diesel vehicles.

Limited studies have attempted to estimate air pollution and GHG emissions from road transport in Singapore. One of the studies conducted in 2005 by the Land Transport Authority (LTA) is shown in Figure 1-1. Private cars and taxis contributed more than half of the CO₂ emissions in the land transport sector. The figure was established officially in 2005, but the current relative contributions should not differ substantially. The number of taxis makes up only 3% of Singapore's overall vehicles but accounts for about 17% of CO₂ emissions due to the higher travel mileage. The same behaviour also applies to buses. Surprisingly, motorcycles and private cars produced less CO₂ emissions with approximately 36% but with a higher share of about 78% of the total vehicle population. This fact demonstrates a realistic case for developing an alternative energy sources scenario for high-emission vehicles such as taxis, buses and commercial vehicles.

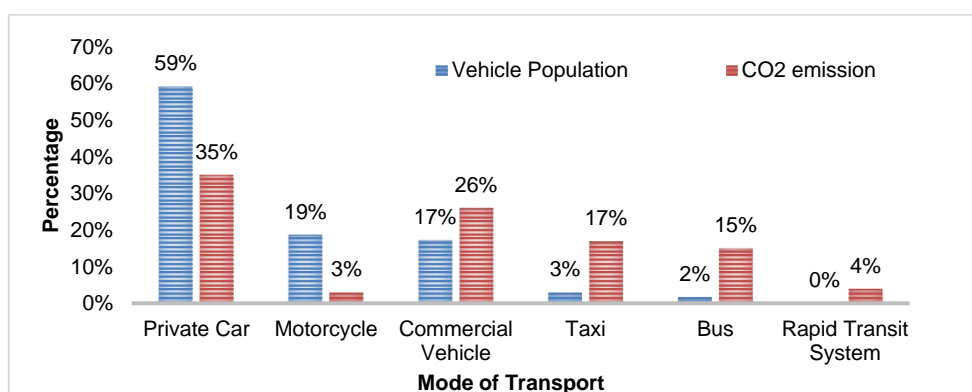

Figure 1-1: Land transport emissions by mode in Singapore 2005 (LTA 2011)

Each motor vehicle in Singapore or elsewhere can be considered a unique case because of its type, size, fuel use, technology, local conditions, and how it is driven and maintained, consequently producing emissions differently. Total emissions are a function of transport activity

and the emission factor (EF). Currently, there are no nationally certified emissions factors that reflect Singapore's local conditions. Adopted series of EFs are typically used according to the selected guideline or emissions model, such as the IPCC Tier 1 approach used by the National Climate Change Secretariat (NCCS) to estimate the transport sector's CO₂ emissions inventory. However, one of the primary sources of uncertainties in emissions quantification is EFs. These uncertainties need to be reduced to manage air quality and strategic climate plans better.

Motor vehicles have contributed 57% of local PM_{2.5} emissions (UNEP 2015; NEA; MEWR 2015). For the specific purpose of air quality improvement, measures have been implemented in place, including:

- The early turnover scheme (ETS). It aims to incentivise vehicle owners to replace old vehicles with models that comply with standards set by the National Environmental Agency (NEA) (NEA; MEWR 2015);
- The carbon emissions-based vehicle scheme (CEVS). It encourages vehicle users to buy low carbon emission vehicles (LTA 2015a);
- The fuel economy labelling scheme (FELS). It promotes the adoption of more fuel-efficient vehicle models (LTA 2012);
- The green vehicle rebate (GVR) scheme (LTA 2012);
- Tightening of emission standards for new diesel and petrol vehicles (NEA; MEWR 2015).

The Singapore government has taken other strategic measures that have indirectly impacted reducing air pollutants and GHG emissions to control vehicle demand and usage. Vehicle quota system (VQS), electronic road pricing (ERP) and off-peak car (OPC) scheme system are some of these measures (for a detailed description of transport policies, see Appendix A).

Singapore's innovative transportation policies as part of environmental conservation instruments have been researched over the last two decades, as evidenced by literature on the subject, e.g. (Olszewski 2007; Chin 2000). Unfortunately, statements therein remain to be verified with more quantitative studies.

Singapore offers excellent conditions for adopting EVs due to its geographically small size and other conducive factors. In 2009, the government set up a task force comprising eight government bodies to study EVs adoption. Two years later, the LTA and Energy Market Authority (EMA) initially launched the EVs test bed programme to decide on the mass application in Singapore. Following promising results, Singapore launched a mass-scale electric car-sharing programme at the end of 2017. Around 1,000 electric cars were initially provided as initial service by BlueSG.

According to the LTA, the number of EVs increased from 5,696 in 2013 to 46,228 by 2019 (LTA 2019a). Although EVs' current market share in Singapore is still relatively low, at about 4.9%, EVs' rapid growth has been seen in recent years. The market share is predicted to reach over 5% in 2020 if significant investment is made in the electrical infrastructure if charging points are provided and more policies incentivising EVs are created (Varga 2013). The prediction seems to correspond with the current EVs development.

EVs are a multidisciplinary topic of research that has been rapidly growing in recent years in Singapore. The efficiency and sustainability of EVs implementation are highly dependent on local conditions. Therefore, EVs adoption in Singapore can be observed and researched from different perspectives such as policy support (Nian et al. 2017), public perception (Xu et al. 2017), charging infrastructure (Xue and Gwee 2017), energy demand (Wagner et al. 2012), and design of taxation (Seng Tat Chua and Masaru Nakano 2013). From the environmental perspective, limited studies of EVs have been made so far. In a lifecycle GHG analysis for taxis in Singapore with an expected lifetime mileage of 1.1 million km, battery-electric taxis showed the lowest emissions than compressed natural gas (CNG) vehicles (Reuter et al. 2013). Moreover, selected BEVs scenarios in urban freight transport showed a potential reduction of CO₂ emissions by 23%-39% (Teoh et al. 2018).

1.1.3 Current gap

Given the earlier brief on the environmental and transport facts in the international and Singaporean context, several gaps are apparent:

- There is a need to quantify the GHG emissions and air pollutants in the transport sector. Various type of transport-related emissions models is available in worldwide applications. However, existing vehicle emissions models have been mainly developed and applied in European countries and the US, based on their fleet characteristics, traffic patterns and environments. The selection of a proper emission model in a transport application is a critical issue since none of the emissions models can provide details and a comprehensive calculation covering all the aspects of traffic emissions on all scales.
- A vehicle emission model that reflects the local conditions of Singapore is not yet available. Unfortunately, there have only been limited efforts of emissions quantification in the last few decades. There is a need to identify the existing emissions and air pollutants trends in the road transport sector.
- Since vehicle emissions modelling depends on the selection of emissions factors, there is a need to determine the aggregated emissions factors that reflect Singapore's condition. Studies need to be performed under more realistic driving conditions where input from other sources can be minimised to address relevant emissions factors. In this case, a tunnel study

could be used to validate EFs from the emissions model. Up to now, no traffic tunnel measurement study has been used for estimating EFs for the South-East Asian region.

- There is a need to reduce air pollutants and CO₂ emissions in the road transport sector, especially in a high-density urban area like Singapore. Future-oriented emissions reduction concepts such as the introduction of EVs can improve the sustainability of Singapore's city-state.

1.2 Research questions and research objective

The researcher poses the following research questions:

How and to what extent are existing emissions models applicable to road transport emissions estimations in Singapore?

What potential EVs scenarios apply to the case study? What is the potential emissions reduction through EVs implementation by 2050?

The research problems mentioned above are broken into several main research objectives:

- To identify significant factors affecting air pollution and emissions from road transport activities and link them to the Singapore conditions;
- To get an understanding of and provide recommendations about the existing emissions models and analyse to what extent the models are reliable;
- To determine an ideal local fleet model and its future trends;
- To demonstrate the procedure of calculating emissions inventory using the selected emissions model approach based on available data sources (considering data quality and quantity);
- To identify aggregated vehicle fleet emissions factors using road tunnel and open road measurement techniques;
- To identify and understand how selected EVs scenarios can reduce the local air pollutants and CO₂ emissions.

The methodologies, results, conclusions, and lessons learned from this study are expected to have applicability in several South-East Asian cities.

1.3 Scope and research design

This PhD research project applies a multidisciplinary approach involving transportation and traffic, environmental, mechanical and policy knowledge. The research is part of the TUM CREATE research institution, "a joint research programme between Technische Universität Munchen (TUM) in Germany and Nanyang Technological University (NTU) in Singapore with funding by the National Research Foundation (NRF) of Singapore". This partnership at TUM

CREATE provides an opportunity to research urban road transport emissions in a densely populated tropical urban area while considering its local conditions.

This research only considers road transport. The development of a comprehensive road transport emissions simulation for the city-state of Singapore is a challenging project. Initially, the research was designed to use the most sophisticated emissions modelling approach to integrate a transport demand model and an emissions model. However, the limited support from related government agencies, data availability, political sensitivity, and limited resources led to a scope shift with a broader transport emissions estimation approach focusing on a smaller case study. A valuable opportunity was given by NTU (Prof. Chang, Prof. Wong and their team) to collaborate and use more scientific approaches for better emissions and air quality estimation by using a road tunnel as a smaller case. Therefore, this research indirectly relates to the NTU-LTA project on “Sustainable Ventilation System for Underground Road System”.

The selected spatial area of the case study clarifies the research boundaries. Table 1-1 proposes the research boundary of the study.

Table 1-1: Proposed research boundary

	City-state level	Link level
Area	<ul style="list-style-type: none"> City-wide area of Singapore 	<ul style="list-style-type: none"> Selected road tunnel: Kallang Paya Expressway (KPE) tunnel Selected open road: e.g. Bukit Batok Str. 52 (minor arterial road)
Purpose	<ul style="list-style-type: none"> A better understanding of emissions and air pollutants caused by road transport activities by applying selected macro-mesoscopic emissions models Identifying and determining selected potential electrification mitigation actions 	<ul style="list-style-type: none"> Determination of aggregated vehicle emission factors (EFs) using tunnel and open roads measurement techniques
Pollutants and emissions	<ul style="list-style-type: none"> Cold start, hot and evaporation emissions Selected air pollutants, and CO₂ emission 	<ul style="list-style-type: none"> Selected air pollutants Hot start emissions
Traffic activity	<ul style="list-style-type: none"> Identification of typical fleet model Average VKT that is recorded by several studies and government statistics 	<ul style="list-style-type: none"> At the KPE tunnel, the traffic is typically free flow with a speed limit of 70km/h. Traffic volume varies from 1,000 – 1,800 vehicles/hour/lane At Bukit Batok Str. 52, the speed limit is 50 km/h

The availability, accessibility and quality of appropriate data are essential parts of any research. Traffic emissions estimations need both transport and non-transport data. Transport data includes vehicle characteristics, road infrastructure characteristics, traffic situations and driver characteristics, while non-transport data comprise meteorologically and other external factors related to the case area.

The following information is used to support the research:

- (1) Primary data: Data collection in the field (air quality measurement inside the tunnel and selected open roadways, traffic video survey near the measurement spots, and others);

- (2) Secondary data: Datasets from the national statistics, LTA, NEA and other governmental institutions;
- (3) Expert adjustment and analysis (based on discussion, if available).

As mentioned in Table 1-1, this research project is divided into two main activities:

- (1) City-state level;
- (2) Link level.

The fuel-based and activity-based emissions estimation approaches are used to understand the magnitude of transportation activities in a defined series of years at the city-state level. The fuel-based approach is typically used for city or regional area sources. The activity-based approach uses an average speed model (e.g. Computer Programme to calculate Emissions from Road Transport - COPERT) for selected road transport air pollutants and emissions. The activity-based emissions model considers several criteria: the objective, modelling scale, modelling approach, data availability, and local conditions. In principle, both approaches are carried out independently. The results of both methods for CO₂ emissions are compared to identify consistency in different emissions estimation approaches.

The study case is confined to the Kallang Paya-Lebar Expressway (KPE) tunnel at the link level. Detailed traffic data needed to be gathered inside and near the tunnel. The NTU-LTA project gathered the field data. Air quality monitoring equipment was installed in selected tunnel segments of the KPE tunnel for approximately ten days. The NTU-LTA project aims to record and identify pollutant concentrations inside the tunnel as well as understand their relationship to the traffic flows. Along with the NTU-LTA project, the researcher uses this opportunity to quantify selected vehicle fleet emissions factors using tunnel measurement techniques.

Selected EVs distribution scenarios are presented and analysed to determine the potential emissions reduction. This analysis focuses on the analysis from an operational point of view. The EVs emissions and their future scenarios vary compared to ICE vehicles, depending on electric power generation and the use-phase of EVs (in this case, travel activities).

1.4 Chapters at a glance

The dissertation's overall structure takes the form of eight chapters, including this introductory chapter, which provides a brief examination of transport emissions and their mitigation through EVs.

Chapter 2 presents a relevant literature review. It covers the essential topic of road transport activities and the impact on air pollution and emissions. Factors affecting road traffic emissions are also discussed in this chapter. Additionally, a brief overview of emission standards is

provided. Moreover, the various applications of emissions models worldwide are identified and summarised.

The criteria influencing emissions model selection are identified and discussed in **Chapter 3**. This chapter proposes a process for selecting a suitable traffic emissions model based on the defined criteria. The case of Singapore is used to apply the proposed selection process of the transport emissions models.

Chapter 4 covers the application of selected emissions calculation approaches in the city-state of Singapore. This chapter introduces bottom-up and top-down approaches, discusses each approach's detail, explains the input data and sources estimating the chosen emissions and air pollutants, and validates both methods' results.

Trends of the Singapore vehicle fleet from 2004 to 2019 are analysed in **Chapter 5**. This trend includes the parameters of engine size, weight, age, fuel, technology, and emission standards, which are considered the main determinants of fuel efficiency and vehicle air pollutants levels. The local transport characteristic is also discussed in this chapter.

Chapter 6 determines the aggregate vehicle EFs under typical traffic conditions inside a long urban road tunnel and on the open road in Singapore. Selected tunnel and open road cases and their characteristics are covered, and the methodology for identifying EFs in the tunnel and on an open road is described. Finally, the results and conclusions of both measurements are presented, along with tunnel experiment results from other countries.

Chapter 7 provides an overview of the status of EVs implementations and existing policies in Singapore. Four EVs fleet scenarios are designed to estimate future CO₂ emissions and air pollution reduction potential.

A summary, discussion, and conclusions of the study, including a recommendation for future work, are given in **Chapter 8**.

2 Vehicle Emissions from Road Transport

Road transport plays a crucial role in contributing to both air pollutants and GHG emissions. This chapter aims to understand the emissions and air pollutants from road transport. The following topics are explained: the source and influencing factors of vehicle emission pollutants, vehicle emission regulation and vehicle emission measurements. Various emissions models and their emission factors (EFs) development are also discussed here. Also, examples of emissions model implementation from around the world are addressed.

2.1 Pollutants emitted by motor vehicles

There are two main types of vehicle emissions: exhaust and evaporation emissions. Exhaust emissions cover cold start and hot (running) emissions. Cold start emissions are defined as emissions produced during the warm-up phase. The catalytic converter is not hot enough to operate at full capacity at this phase, and the air/fuel mixture is often fuel-rich to ensure that the engine will start.

Hot exhaust emissions are produced when a vehicle's engine and exhaust after-treatment system reaches their average operating temperature, typically around 70-90°C (Boulter et al. 2009). They are mainly a result of incomplete fuel combustion, although nitrogen oxides (NO_x) are primarily caused by fuel-lean mixtures and the resulting high in-cylinder temperatures.

According to (Sundvor et al. 2012), evaporation emissions occur in several ways:

- (1) Diurnal: The evaporation increases as the temperature rises during the day, regardless of whether a motor vehicle is running or not.
- (2) Running losses: The engine and exhaust system can vapourise fuel when the motor vehicle is running.
- (3) Refuelling: The act of refuelling expels fuel vapours from fuel tanks.
- (4) Hot soak: The engine remains temporarily hot after the engine is turned off, and the vapourisation continues to occur, e.g., during the parking condition.

Besides that, non-exhaust emissions play a significant role in contributing to air pollutants, especially particulate matter (PM). The most significant non-exhaust emissions sources are tyre wear, brake wear, road surface wear, and road dust resuspension (Thorpe et al. 2007). Other potential sources are abrasion of the wheel bearing, corrosion of other vehicle components, clutch and engine wear, street furniture and clutch barrier.

Various air pollutants and GHGs emissions are released by vehicles. The following sections describe the pollutants according to the respective source. Effects on health and existing

emission policies or technologies that have been introduced and implemented in the field are included.

2.1.1 Carbon dioxide (CO₂)

CO₂ is a product of the combustion process. All the carbons in the fuel are eventually turned into either CO or CO₂. The total amount of CO₂ exhaust is equivalent (99% of carbon is emitted as CO₂) to fuel consumption (Trachet and Madireddy 2010), depending on the fuel type's carbon content. Generally, diesel vehicles are more fuel-efficient compared to their gasoline alternative. CO₂ is also far more closely linked to engine size (and vehicle mass) than harmful exhaust gases (Wang, McGlinchy 2009b).

CO₂ is the dominating GHG emission with 90% compared to methane (CH₄) with around 9% and Nitrous Oxide (N₂O) with around 1%. The GHG emissions affect global warming and cause other sustainability issues in the environment. Some policies to reduce carbon emissions from vehicles have been implemented in Singapore, such as CEVS and Fuel Economic Labelling Scheme (FELS), aiming to improve air quality and promote fuel efficiency (LTA 2014b).

2.1.2 Carbon monoxide (CO)

CO is mainly produced by incomplete combustion, especially in gasoline vehicles. This happens when the carbon in the fuel is partly oxidised, resulting in the formation of CO rather than CO₂ (EEA 2016b). Moreover, CO can occur during a cold start condition or when driving at a significant elevation (Trachet and Madireddy 2010). A transient engine operation such as acceleration and high torque demand can produce some additional CO. Old petrol-engine vehicles are the primary sources of CO emissions.

CO is colourless and odourless but highly toxic because it binds with haemoglobin to form Carboxyhaemoglobin (COHb) that enters the lungs after inhalation. This pollutant lowers the flow of oxygen in the bloodstream and can lead to headaches, dizziness and even death. A dangerous circumstance can be found in low-ventilated spaces such as parking lots and tunnels. CO also leads to the formation of smog and ground-level ozone (EEA 2016b). However, CO emissions from gasoline can be reduced using a three-way catalyst. Oxidation of catalyst converts CO and Hydrocarbon (HC) to CO₂ and water (EEA 2016b).

2.1.3 Hydrocarbons (HCs) and volatile organic compounds (VOCs)

HCs are part of a larger group of VOCs. HCs consist of hydrogen and carbon compounds only, whereas VOCs may contain other elements. HCs and VOCs have a broad range of properties, such as benzene (EU 2016). They are produced from incomplete combustion and through evaporation. For cold start periods, a passenger car with existing emission control equipment is

characterised by the catalyst's inefficient use as the catalyst needs to run several times until it reaches operating temperature (Fredrich and Reis 2014).

Cancer, central nervous system disorders, liver and kidney damage, reproductive disorders, and congenital disabilities are all possible chronic health effects of HCs and VOCs (EU 2016). VOCs contribute to the formation of ground-level ozone and photochemical smog in the atmosphere layers. Moreover, ozone irritates the eyes, causes lung damage, and aggravates respiratory problems.

2.1.4 Particulate matter (PM)

Similar to CO, for exhaust emissions, PM is a product of incomplete combustion. It is a complex mixture of both primary and secondary PM. Primary PM refers to the fraction of PM that is released directly into the atmosphere. A secondary PM forms in the atmosphere following the release of precursor gases (mainly nitrogen oxides (NO_x), ammonia (NH₃), sulphur dioxide (SO₂) and some VOCs) (EU 2016). PM particles can be divided into PM_{2.5} and PM₁₀, representing particles with a diameter of less than 2.5µm and 10 µm, respectively (Timmers and Achten 2016). PM-exhaust is significant for diesel engine vehicles but not for gasoline engine vehicles except for direct-injected gasoline engines.

Besides, the non-exhaust PM also contributes almost equally to exhaust PM emissions. The relative contributions to non-exhaust PM-related emissions range between 16-55% (brake wear), 5-30% (tyre wear) and 28-59% (road dust resuspension) (Grigoratos, 2014). The total amount of related non-exhaust emissions will increase in the future due to the stricter control of exhaust emissions.

PM is one of the severe pollutants contributing to health issues on a local scale. The most harmful to health are PM_{2.5} particles. Those particles can penetrate sensitive areas of the respiratory system and cause cancers, cardiovascular and lung diseases (Chambliss et al. 2013; WHO 2018).

2.1.5 Nitrogen oxides (NO_x)

NO_x is a common term to describe a mixture of nitric oxide (NO) and nitrogen dioxide (NO₂). A combination of oxygen with nitrogen in the air forms NO_x. Engine-out NO_x emissions consist mainly of NO (90–95%) (Vestreng et al. 2009; Fredrich and Reis 2014) showed that the emission concentration usually arises due to the high combustion temperature (T>1500°C). A brief report published by (Transport and Environment 2015) claimed that a typical diesel car emits ten times more NO_x than an equivalent petrol car. According to (OECD 2002), the primary contributors of NO_x are heavy-duty vehicles and buses due to their intensive travel activities.

Their contribution was about 5% of the total global vehicle population, but they contributed to about half of the total motor vehicle-related NO_x emissions.

NO₂ is odourless, colourless, tasteless, and harmless to health. However, it is oxidised to NO₂ in the atmosphere. NO₂ is red-brownish in colour, poisonous and has a distinct odour. It causes health issues such as bronchitis and lung diseases. At high concentrations, NO₂ affects global warming. NO₂ also contributes to the acidification and eutrophication of waters and soils (EEA 2016b).

2.2 Factors influencing motor vehicle emissions

Various factors affect the emissions from a motorised vehicle. Some literature (Franco et al. 2013; Duennelbeil et al. 2012; Spence et al. 2009; Atjay 2005; Smit et al. 2009) has explained the factors that influence the number of emissions and fuel consumption from a motor vehicle. All the influencing factors are listed and categorised in Table 2-1. These factors are frequently interconnected and may influence different emission types. For instance, humidity and higher ambient temperature affect air conditioning and influence hot exhaust emissions and evaporative emissions. Vehicle operation modes (e.g., acceleration, deceleration) also significantly affect emissions and fuel consumption.

Table 2-1: Factors influencing road vehicle emissions (Franco et al. 2013; Duennelbeil et al. 2012; Spence et al. 2009; Atjay 2005; Smit et al. 2009; Chiang et al. 2007)

Vehicle characteristics	propulsion type (diesel, gasoline, alternative fuels), engine size, engine type (two-stroke, four-stroke), transmission type (automatic, manual), reduction technologies (particulate filter, selective catalytic reduction, exhaust gas recirculation), emission standards
Road infrastructure characteristics	road design, road type, road gradient, road width, road condition, the surface quality of pavement, gradient, detour level
Traffic situations	speed limit, average speed, traffic flow, level of congestion, urban or non-urban area
Vehicle operations	acceleration, deceleration, idle, cruise, gear change pattern, vehicle use pattern
Meteorological	ambient temperature, humidity, wind speed, altitude, rain, fog, the use of air conditioning
Other country-specific external factors	Vehicle fleet composition (age profile, utilisation, vehicle and traffic mix), the effectiveness of inspection and maintenance, fuel properties, emission control legislation, geographic location, scrappage policy (ageing effects)

Emissions depend on vehicle characteristics. Older vehicles and higher mileage vehicles have higher EFs and lower fuel efficiencies due to the emission control degradations and less stringent emission standards at the manufacturing time. The type and amount of pollutants emitted are also affected by vehicle type. Passenger cars, motorcycles and light-duty vehicles (LDVs) in Singapore primarily use gasoline as fuel, whereas taxis, buses and heavy-duty vehicles (HDVs) typically use diesel (see Section 4.4.1). A lighter vehicle with a smaller engine tends to have a better fuel economy. However, diesel-fuelled vehicles, such as HDVs, have

better fuel efficiency by weight than gasoline-fueled LDVs. Different fuel type also produces different emissions. Diesel vehicles emit NO_x mainly, with lower amounts of CO, PM, SO₂ and VOCs. Gasoline vehicles produce CO mostly, with less amount of VOCs and NO_x.

2.3 Regulating vehicle emission standards

Many measures have been adopted for controlling and reducing emissions from motor vehicles. The introduction of the newest engine technologies can achieve a substantial emissions reduction contribution. One of the most common approaches is to introduce vehicle emission standards. Vehicle emission standards have been implemented in various countries since the 1970s (Faiz et al. 1996). However, along with the development, two principal international standard systems, the United States (US) and Europe, became emphasised.

The US emission standards are established by the US Environmental Protection Agency (EPA), while the United Nations Economic Commission establishes the Euro standards for Europe (ECE) for use in the European Union (EU) countries (Faiz et al. 1996). The US emission standards have been mostly adopted in American countries such as Canada, Mexico, Brazil, and Chile. In Asia, several countries (e.g. Singapore, Thailand, and Indonesia) have been following the Euro standards. Some exception countries like India and China are using a local name of emission standard in practice, but they still adopt the Euro standard. Examples are the Bharat stage in India and China standard in China.

Table 2-2 shows a change in the performance of emission standards in the US, Europe and Singapore for petrol-driven passenger cars. The table shows that the US standard tends to have stricter NO_x but less strict CO than the EU standard. Singapore follows the EU standard; however, the implementation of the standard is delayed by some years.

Table 2-2: Changes in performance standards for petrol-driven passenger cars and LDVs (in gramme/km) (Dieselnet 2021; Continental 2019)

1992		Euro I: CO (2.72); HC + NOx (1.97)	
1993		↓	
1994	Tier I: CO (2.15); HC (0.25); NOx (0.25)		Euro I
1995	↓		↓
1996		Euro II: CO (2.20); HC + NOx (0.50)	
1997		↓	
1998			
1999			
2000		Euro III: CO (2.30); HC (0.20); NOx (0.15)	
2001		↓	Euro II
2002			↓
2003			
2004	Tier II: CO (2.12); HC (0.009); NOx (0.03)*	↓	
2005		Euro IV: CO (1.00); HC (0.10); NOx (0.08); PM (0.005)	
2006		↓	
2007			
2008			
2009		Euro V: CO (1.00); HC (0.10); NOx (0.06); PM (0.005)	
2010		↓	
2011			
2012			
2013			
2014		Euro VI: CO (1.00); HC (0.10); NOx (0.06); PM (0.005)	Euro IV
2015		↓	↓
2016			
2017	Tier III: CO (2.65); HC (0.002); NMHC + NOx (0.10)**	↓	Euro VI
2018	↓		↓
2019			
2020		↓	

Note: *Bin 5 for US standard, **Bin 160 or US standard (Bin 5 Tier II is equivalent to Bin 160 Tier III)

The Euro and US standards are not directly comparable due to the different vehicle emissions limits setting and testing procedures, but test results in grammes per kilometre are generally in the same order. It is essential to understand and differentiate between technology-following and technology-forcing emission standards in regulating vehicle emissions. On the one hand, technology-following standards are based on the demonstrated technology that proves some vehicles can meet emission levels (Faiz et al. 1996). Therefore, vehicle manufacturers have less incentive and lower technical and financial risks in meeting the technology-following standard to reduce air pollutant emissions.

On the other hand, technology-forcing standards are based on the perspective that the standard should be set at a certain level considering what is technologically feasible, although not yet demonstrated in practice. Automobile manufacturers are forced to research, develop innovations and commercialise new technologies to meet the standard (Faiz et al. 1996; Hascic et al. 2009). The Euro standard has often been set according to the technology-following approach. In contrast, the US has adopted the technology-forcing standard. As a result, the Euro emission standards have lagged noticeably behind the US standards regarding strictness.

As the Volkswagen emissions scandal was confirmed by the end of 2015, the procedure of setting up stricter Euro standards should be taken with more care in the future, especially by considering the real-world emission tests on the road. In the US, the Volkswagen light-duty diesel vehicles cause NO_x emissions up to 40 times above emission standards measured on the

road (Tanaka et al. 2018). This scandal brought this issue under the spotlight and led to a range of concerns in the environmental, health and policy domains.

Euro emission standards have been progressively introduced and implemented in Singapore to support better air quality. However, in the early implementation of emission standards at the beginning of the 1990s, Singapore adopted the US standard (US 40 CFR 86.410-80) for motorcycles only. Singapore started to introduce the European (ECE R15-04) emission standards for passenger cars in 1986. Since 1st July 1992, all new petrol-fuelled vehicles registered in Singapore have been required to comply with ECE 83 or current Japanese emission regulations (Dieselnet 2021).

The Singapore government periodically adapts the standards to tighten the vehicle emissions limit as innovative technologies are developing. The progress of emission standards development according to the vehicle type and fuel type is described in Figure 2-1. Besides, to support better air quality and ensure that vehicles on the roads comply with the prescribed standards, all vehicles must undergo periodic inspection and maintenance. The implementation of these emission standards will undoubtedly benefit the whole city-state.

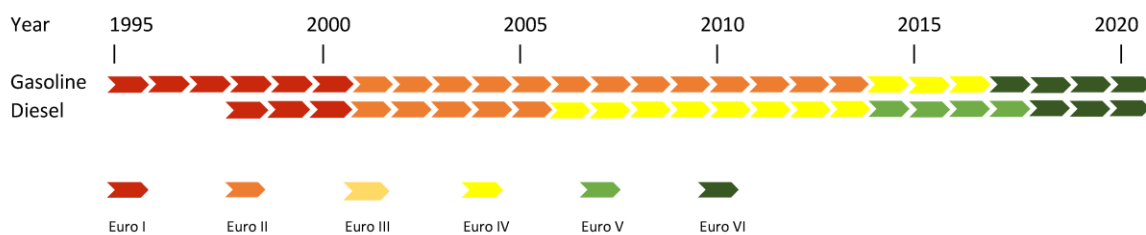

Figure 2-1: Emission standards for Singapore passenger cars

2.4 Vehicle emissions measurements

An earlier review of vehicle emissions measurements was conducted by (Faiz et al. 1996; Franco et al. 2013). Advantages and disadvantages were discussed to get a better view and understanding of each condition.

Vehicle emissions measurement is complex because vehicle emissions depend on various factors (as explained in section 2.2). Vehicle emissions measurements are usually conducted to define specific pollutants EFs and their dependency on fuel characteristics, vehicle characteristics, and operating conditions, measured *under controlled* and *real-world conditions*. Most of the emissions models are based on official emissions measurements under controlled conditions. Still, real-world measurements have been mainly conducted to validate the emissions models further.

2.4.1 Emission measurement under the controlled conditions

Under the controlled conditions, the emissions measurement is conducted either on chassis or engine dynamometer in laboratories. Vehicle load and ambient conditions are consistent in a laboratory. Therefore, the test results are considered stable, accurate and reproducible (Franco et al. 2013).

(1) Chassis dynamometers

Emissions from the vehicle are conventionally measured in a chassis dynamometer (or roller bench). During the test, the vehicle wheels are placed on connecting with rollers which can be adjusted to simulate aerodynamic and frictional resistance. The vehicle is tied down to keep it stationary, so a trained driver is ready to operate the vehicle under a pre-defined time-speed profile (driving cycle) and gear change pattern as shown in a driver's aid monitor. The driver should follow the driving cycle as close as possible (i.e. within a specified tolerance) to the defined cycle (Boulter et al. 2007b; Franco et al. 2013). An illustration of a chassis dynamometer test facility is shown in Figure 2-2.

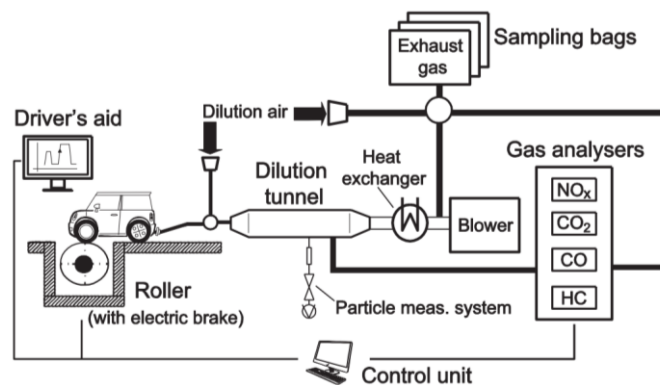

Figure 2-2: Schematic of a chassis-dynamometer emissions test facility (Franco et al. 2013)

As the vehicle progresses through the pre-defined driving cycle, sets of instruments are applied, and the emissions are monitored continuously from the tailpipe. However, the vehicle exhaust gas is collected only in sampling bags using exhaust gas analysers with a high range of detectors. Sampling bags are used for later analysis or other processes by online chemical analysers attached to the sampling line, which may require dilution with ambient air.

The vehicle load corresponds typically to the vehicle's weight in running order, including the driver in a regular normal driving use according to the given driving cycle. The laboratory operators can control the vehicle load setting to simulate aerodynamic resistance. The influence of weight or load on a passenger car emissions is relatively low compared to a heavy-duty vehicle (HDV). Alternatively, vehicles can also be tested in the field to verify their common operating boundary, which is typically represented in a driving cycle.

(2) Engine dynamometers

According to (Franco et al. 2013), an instrument that directly simulates the resistive power in the engine power output. The dynamometer shaft is directly linked to the engine shaft in the engine dynamometer test cell. Fully transient dynamometers may place or absorb any specified load (within limits) to the engine, even during load and speed change conditions. The engine test cell can be adjusted to the climate condition. The engine dynamometer measures power at the engine's flywheel, where no transmission or driveline losses influence the results.

A minor difference between chassis and engine dynamometer results was in-vehicle testing using chassis and engine dynamometers. An agreement was at 95% for air pollutants, CO₂, fuel consumption and power when multiple tests were performed (Figure 2-3).

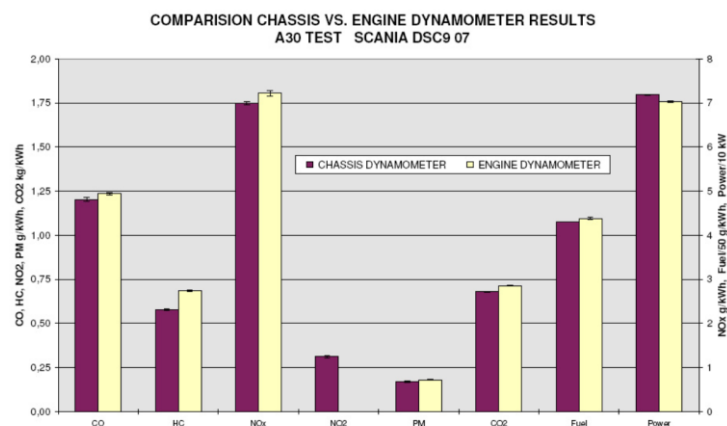

Figure 2-3: Chassis vs engine dynamometer where the emissions are expressed in g/kWh (Hallsten 2009)

2.4.2 Emission measurement in real-world conditions

Emission measurements must be operated outside the laboratory's boundaries to acquire vehicle emissions that directly represent the actual field conditions. The real-world emissions measurements can be done in several ways, such as through tunnel studies, on-board emissions measurements, on-road measurements (chase), and remote sensing.

(1) Tunnel studies

Since the 1980s, road tunnel measurement under real-world conditions has often been used to validate EFs from the dynamometer test and emission model (Peace et al. 2004; Sturm et al. 2001). However, finding a tunnel close to or within a city is not always possible where the traffic emissions are released and present real-world conditions. Several studies found that the emission level of some air pollutants is over or underestimated. Therefore, tunnel measurement contributes to improving an understanding of model accuracy and vehicles' real-world emission behaviour. Table 2-3 summarises the past tunnel studies that were conducted to validate several emission models. A tunnel case in Singapore is explained in detail in Chapter 6.

Table 2-3: Summary of pollutants measured in the tunnel and the associated methods

(Hausberger et al. 2003b)	2001	NO _x	HDV	Plabutschunnel, Austria. Nov 2001	HBEFA 1999, PHEM
(Colberg et al. 2005)	2002	NO _x , CO, VOC	LDV, HDV	Gubrist road tunnel, Switzerland	HBEFA 1999, HBEFA 2004
(Chiang et al. 2007)	2007	NO _x , CO, HC, SO ₂ , PM ₁₀	HDV	Freeway tunnel, Southern Taiwan	Dynamometer test
(Barlow and Boulter 2009; Boulter and Mccrae 2007a)	2005-2006	NO, NO ₂ , O ₃	Car, LGV, HDV	Hatfield tunnel, UK	UK EFs, NAEI, COPERT III, ARTEMIS, PHEM and MODEM

(2) On-board measurements using portable emission measurement systems (PEMS)

PEMS are complete sets of emission measurement instruments that can be carried on board the vehicle under research (Frey and Unal 2002; Frey et al. 2003). Such systems can provide instantaneous emission factors of selected pollutants with satisfactory levels of accuracy. A PEMS unit usually comprises a set of gas analysers with heated sample lines directly connected to the tailpipe, an engine diagnostics scanner designed to connect with the OBD (on-board diagnostics) link of the vehicle, and an on-board computer that provides data regarding emissions, fuel consumption, vehicle speed, engine speed and temperature, throttle position and other parameters.



Figure 2-4: Passenger car instrumented with PEMS (Franco et al. 2013)

PEMS systems typically measure instantaneous raw exhaust emissions of NO_x, Total Hydro Carbon (THC), CO₂, and CO. Portable particle mass analysers have become commercially available after extensive testing (Mamakos et al. 2011). Exhaust flow meters are attached to the tailpipe (alternatively, the exhaust flow rate can be calculated from engine operating data, known engine and fuel properties, and measured CO₂ concentrations in the exhaust gas). At the same time, a GPS and a weather station are usually installed on the vehicle's exterior. PEMS systems have experienced remarkable technological development in the past few years, with significant reductions in size, weight, piping and cabling complexity, improved gas measurement principles, reduced analyser response times, and overall performance similar to conventional

fixed laboratory equipment. An illustration of PEMS that is installed in a passenger car is shown in Figure 2-4.

(3) On-road measurements (chase)

An on-road measurement is also called chase or plume chase. In this method, individual vehicles are followed by a mobile laboratory (usually on board a van or trailer) that is instrumented with gas and aerosol measurement equipment (ideal instruments have fast time response and high sensitivity, such as laser spectrometers), plus meteorological and positioning instruments, and even video recording equipment to monitor traffic situations (Shorter et al. 2005).

CO₂ is used as a combustion tracer, and the results indicate the relative concentration of the pollutant of interest per CO₂ concentration value. These mobile laboratories can capture the exhaust plume of the vehicle being followed, thus providing real-world emissions data under a wide range of operating and environmental conditions. Mobile emission laboratories make it possible to study a statistically representative sample of vehicles for fleet characterisation. One disadvantage is that such measurements are best conducted on a test track due to traffic safety considerations (Franco et al. 2013). As well, a minimum distance between the laboratory sensors and the vehicle being chased is ten meters unless the laboratory is mounted on a trailer. Furthermore, a maximum chase speed of approximately 120 km/h is recommended by (Morawska et al., 2007).

(4) Remote sensing

In remote sensing, instantaneous pollutant concentrations are determined as vehicles pass by a roadway measurement station (Davison et al. 2020). Remote sensing equipment can take several readings of the ratios of concentrations for each exhaust plume analysed, correct for background levels and report a mean value for each passing vehicle. Infrared and ultraviolet light of specific wavelengths from a source passes through the exhaust plume to a detector wherein the amount of light absorbed is proportional to the concentration of CO, CO₂, or THC (measured in the infra-red band) and NO_x measured in the ultra-violet band (Bishop et al. 1996). Remote sensing can be used to determine pollutant molar ratios, offering a quick and effective method of monitoring exhaust emissions from in-use vehicles under real-world driving operation.

Validation of traffic emission models can be performed in various ways. Most studies employed either tunnel methods or ambient concentration methods. Other measurement methods were completed using remote sensing, mass-balance, on-board measurements and laboratory measurements (Smit et al. 2010).

2.4.3 Advantages and disadvantages of real-world and under-controlled conditions

Table 2-4 summarises some advantages and disadvantages of real-world and controlled conditions. Real-world conditions measurements are mainly triggered by cost and time savings as well as human resource considerations. Validation of an emissions model for conventional and advanced vehicle technologies will add significantly to the model's accuracy.

Table 2-4: Advantages and disadvantages of under-controlled and real-world conditions

	Advantages	Disadvantages	Advantages	Disadvantages
Vehicles	<ul style="list-style-type: none"> ▪ Accurate estimation only for individual vehicles or representativeness of vehicles 	<ul style="list-style-type: none"> ▪ Designed for individual vehicles ▪ Not possible to make full-scale vehicle tests due to the limited sources ▪ Only limited vehicles number under a limited range can be tested ▪ May not be representative of the entire vehicles fleet 	<ul style="list-style-type: none"> ▪ (n/a) 	<ul style="list-style-type: none"> ▪ Possible to have only aggregated vehicle test
Operating conditions	<ul style="list-style-type: none"> ▪ Ability to control the measurement conditions 	<ul style="list-style-type: none"> ▪ May not necessarily represent real-world conditions 	<ul style="list-style-type: none"> ▪ Represent real-world conditions 	<ul style="list-style-type: none"> ▪ Road and traffic conditions are not sufficiently consistent ▪ Meteorological condition changes according to seasons
Resources	<ul style="list-style-type: none"> ▪ Efficient in time and cost 	<ul style="list-style-type: none"> ▪ (n/a) 	<ul style="list-style-type: none"> ▪ (n/a) 	<ul style="list-style-type: none"> ▪ Time-consuming ▪ Costly ▪ Human resources consuming

2.5 Emission factors (EFs) development

EFs is one of the primary sources of uncertainties in emissions calculation because EFs given by the emissions model are typically based on dynamometer test under controlled conditions. A study done by (Hausberger et al. 2003b) showed an apparent underestimation of the NO_x emission level. Real-world measurements of EFs generate aggregate emission parameters that define the total emissions from the vehicle fleet. They are commonly performed in tunnels, where the atmosphere provides a high degree of control over the factors affecting traffic emissions. However, more representative measurements considering all environmental conditions may be achieved by conducting measurements in open-road environments. The EFs calculated in real-world conditions are used to validate the EFs model determined using dynamometer measurements. They are used as a parameter in emissions models that estimate pollutant emissions and concentrations (Jamriska and Morawska 2001). Detailed explanations and real-world case studies of EFs development are discussed in Chapter 6.

2.6 State of the art of emissions models

Traffic emissions modelling becomes a critical concern, particularly in urban areas, to understand transport activities' performance and impact on air pollutants and emissions. This fact is supported by a considerable number of vehicle emissions models that have been

generated in the last few decades, especially in Europe and the US. Such emissions models mainly deal with database inventory, emissions projection, fuel consumption estimation, policy scenario calculation, air pollution, and climate change issues. Estimating air pollutants and emissions will substantially influence the related stakeholders to set and implement the appropriate mitigation strategies.

Global emissions models are listed in Table 2-5, which are developed either in European countries or in the US. Those models have been gradually developed and updated to reflect changes in methodology, type of emissions, quality of data, legislation, and control technologies. A comparative analysis of selected European and US emissions models is described later to gain a broader understanding of the models' structure and assumptions and identify the differences between the models regarding data, methodology, and emissions information.

2.6.1 Classification of emissions models

There are numerous ways to classify the existing emissions models, even though there might be an overlap between them to a certain degree. The classification can be based on several aspects such as consideration of congestions (Smit et al. 2008), the aggregation level and the level of detail (Treiber and Kesting 2013), the treatment of kinematic effects (e.g. the effect of different speed-time profiles) (Smit et al. 2006) and the generic type or the operational basis (Mahmod and Arem 2008; Boulter et al. 2007a; Boulter et al. 2009; Wismans et al. 2011; Spence et al. 2009; Hickman et al. 2009; Wang and McGlinchy 2009a).

Most of the literature discussed the classification based on the generic type to understand the emissions calculation approach better. Moreover, the calculation approach is strongly related to the detail level of input data and the accuracy and sensitivity of the output. The emissions modelling approach represented below is based on the generic type. It is classified into five types with increasing levels of complexity.

However, according to (Jamriska and Morawska 2001), there are two types of emissions models in general:

- (1) emission rate models, which determine the emission rate for an average vehicle under typical operating conditions.
- (2) emission inventory models, which integrate the performance of travel demand models, traffic simulation models and emission rate models to estimate total vehicle fleet emissions.

Table 2-5: Overview of the emissions models in Europe and the US

Europe	ARTEMIS (Assessment of R eliability of T ransport E mission M odels and I nventory S ystems)	Some EU countries
	COPERT (C omputer P rogram to C alculate E missions from R oad T ransport)	EU countries, Australia, several Latin American and African countries
	DGV (Digitized Graz Method, superseded by PHEM)	Austria
	GLOBEMI (G lobal E mission M odel)	Austria
	HBEFA (H andbook E mission F actor for Road Transport)	Some EU countries
	LIISA	Finland
	MEET (M ethodologies for E stimating A ir P ollutants E missions from T ransport)	The UK
	MODEM (M odelling of E missions and C onsumptions in U rban A reas)	France, Germany, the UK
	NAEI (N ational A tmosphere E mission I nventory)	The UK
	PHEM (P assenger C ar and H eavy-Duty E mission M odel)	Austria and some EU countries
	TREMOM (T ransport E mission M odel)	Germany
	TREMOVE	Some EU countries
	VERSIT+ (V ERkeers S ITUatie M odel)	The Netherlands
	VeTESS (V ehicle T ransient E mission S imulation S oftware)	
	US	CMEM (C omprehensive M odal E missions M odel)
EMFAC (California Air Resources Board E mission F actor)		California-USA
MEASURE (M obile E missions A ssessment S ystem for U rban and R egional E valuation)		Atlanta-USA
MOBILE6 → replaced by MOVES		The USA
MOVES (M ulti-scale M otor V ehicle E mission S imulator M odel)		The USA
NMIM (N ational M obile I nventory M odel) → replaced by MOVES		The USA
VT-Micro model (V irginia T ech M icroscopic energy and emission model)		Virginia-USA

2.6.2 Overview of the selected emissions models

The following explanation compares several emissions models developed and primarily used by the global community: the US MOVES, EMFAC, and the European HBEFA, COPERT and PHEM (Table 2-6). Apart from serving as a summary, this section provides insight into the tools now appropriate for possible policymaking in Singapore.

Table 2-6: Overview of selected emissions models

Emissions model	MOVES	EMFAC	HBEFA	COPERT	PHEM
Latest version	MOVES 3.0.1 (2021)	EMFAC 2021	HBEFA 4.1 (Aug 2018)	COPERT 5.4 COPERT street level	PHEM 11
Commissioner	EPA US (Environmental Protection Agency – the United States)	The California Air Resources Board (CARB)	<ul style="list-style-type: none"> - Federal Environmental Agencies (Germany, Austria, Switzerland) - Swedish Road Administration (Sweden) - Norwegian Pollution Control Authority (Norway) - ADEME - French Environment and Energy Management Agency (France) 	The European Environment Agency (EEA)	(n/a)
Developer	US EPA's Office of Transportation and Air Quality (OTAQ)	The California Air Resources Board (CARB)	INFRAS on behalf of the Environment Agencies of the countries involved	EMISIA (a spin-off company of the Aristotle University of Thessaloniki-LAT)	TU Graz
Purpose	<ul style="list-style-type: none"> - Emission model for road transport emissions - Policies scenarios such as state implementation plan (SIP) and transportation conformity determination 	<ul style="list-style-type: none"> - Emission model for road transport operating in California - Emission inventory - Emission rates database - Policies scenario and project-level assessment 	<ul style="list-style-type: none"> - Emission factors database (public version) - Input for air quality model - Emission inventory - Traffic activity data (expert version) - Emission model (expert version) 	<ul style="list-style-type: none"> - Emission model - Emission inventory - Database for emission factors and traffic activity data 	Emission factor model for various driving styles, traffic situations and vehicle technologies
Resolution - Scale - Time	<ul style="list-style-type: none"> - National State, county and project - Various time aggregation levels (year, months, day and hour) 	<ul style="list-style-type: none"> - National State, county, project and scenario 	<ul style="list-style-type: none"> - Street-level + upwards - Day upwards 	<ul style="list-style-type: none"> - National, regional and local scale - Yearly (possible to daily) 	<ul style="list-style-type: none"> - Link to micro-scale - 1 Hz
Software - Platform - Availability	<ul style="list-style-type: none"> - Builds on JAVATM platform and uses a different MariaDB database server - Freely distributed and available at EPA's website 	<ul style="list-style-type: none"> - Python and MySQL database 	<ul style="list-style-type: none"> - MS Access application - The public version (Emission Factor Module) is available for 250 Euro - Expert version is not publicly available 	<ul style="list-style-type: none"> - MS-Office for Windows application (with data stored in SQL since COPERT5) - Free distributed 	(n/a)

MOVES

Developed by the EPA US, the MOVES is the state-of-the-art emissions model in the USA intended to replace MOBILE6, NONROAD and NMIM (EPA US 2018a). The tool can estimate fuel emission rates, emission inventories and total energy consumption from an on-road (expansion capabilities from MOBILE) and off-road mobile source pollutants. It incorporates critical current emissions test results, considers advancements in fleet technology and legislation, and a better understanding of in-use emission standards and the conditions that shape them (EPA US 2012).

As illustrated in Figure 2-5, the basic framework of MOVES consists of (1) total activity generator (TAG), (2) operating mode distribution generator (OMDG), (3) source bin distribution generator (SBDG) and (4) emission calculator (Huang and Hu 2018; Vallamsundar and Lin 2011). The TAG defines the base year vehicle population and vehicle mileage travelled (VMT) to a target analysis year using growth factors, then allocates them based on road type, vehicle class, vehicle age and time, and projected data from a variety of sources. The SBDG generates source bin fractions, which are then used to determine weighted emission rates. However, in MOVES the vehicle is classified into different source bins, which are described to represent unique combinations of vehicle class, model year group, vehicle weight, engine size, engine technology and fuel type (Abou-Senna et al. 2013).

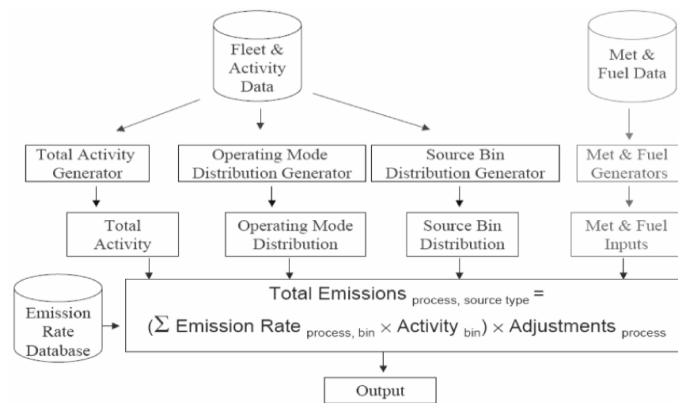

Figure 2-5: The emission estimation process in MOVES (Huang and Hu 2018; Vallamsundar and Lin 2011)

The OMDG classifies vehicle operating mode into different bins associated with vehicle-specific power (VSP) and specific speed as well as develops mode distribution based on 40 pre-defined driving cycles. The VSP represents the power demand placed on a vehicle under various driving modes and various speeds. The calculation of VSP for LDV gasoline is shown as follows:

$$VSP = v \times [1.1a + 0.132] + 0.000302 \times v^3 \quad \text{Equation 2-1}$$

where, v is the vehicle speed (km/h); a is the acceleration (m/s^2).

After the distribution of total activity into different bins, the emission calculator assigns an emission rate for each unique combination of source and operating mode bins, and the emission rates are aggregated for each vehicle type. A few correction factors are applied to the emission rates to adjust for local conditions such as temperature, air conditioning and fuel effects. The emission calculator combines modal-based emission rates with associated vehicle activities.

Table 2-7: MOVES overview (summarised from (EPA US 2018a, 2018b; US EPA 2015; U.S. EPA 2021))

Purpose	<ul style="list-style-type: none"> - Emission model for road transport (inventory and forecast) - Emission rates database and calculation (depending on the area and purpose of analysis) - Policies scenarios such as State Implementation Plan (SIP) and transportation conformity analysis
Historical development	<ul style="list-style-type: none"> - A version of MOVES: <ul style="list-style-type: none"> ▪ MOBILE (v.1 in 1978 – v.6 in 2004) and NON ROAD ▪ MOVES 2009 ▪ MOVES 2010b (Apr 2012) ▪ MOVES 2014b (Nov 2015) ▪ MOVES 3.0.1 (2021) - Official website: http://www.epa.gov/otaq/models/moves/
Type of program	
Generic type	Driving cycle approach and instantaneous model
Derivation of EFs	Dynamometer test data and onboard test data for VSP based on mode bins
Operational	Build on JAVA™ platform and uses a different MariaDB database server
The sample of case studies	<p>VISSIM/MOVES integration to investigate the effect on CO₂ emissions (Abou-Senna et al. 2013)</p> <p>A case area of Houston Drayage (Fulper et al. 2011)</p> <p>A case study of Kansas (Koupal et al. 2012)</p>
Resolution	
Spatial	The national state, county and project
Temporal	<p>Various time aggregation levels (year, month, day and hour)</p> <p>The analysis year 1999 - 2060</p>
Data entry	
National	National default database and regionally specific data
County	Use of default data and specific county data
Project	<p>Detailed local specific data such as:</p> <p>(1) Travel models (link characteristics, driving pattern, vehicle operation modes, vehicle fleet characteristics, speed distribution, road type, vehicle operating area, etc.)</p> <p>(2) Local sources (meteorological information, fuel supply & quality, inspection & maintenance program, etc.)</p>
Derived from transportation model	Volume or VTM (vehicle travelled miles), speed (average for each road link), fleet mix (cars vs trucks)
Other operational	Instantaneous speed curve (driving pattern), torque/power, engine speed, road gradient, vehicle load, air condition, gradient,
Defined traffic situation	Combination of road type (affected by speed distribution), average bin speed, road grade
Pollutants/ outputs	(depends on simulation level)
Global pollutants	CO ₂ , CH ₄ , N ₂
Air pollutants	<p>Regulated: CO, HC, NO_x, PM_{2.5}</p> <p>Other: NH₃, SO₂, NO, VOC, toxics (e.g., benzene, naphthalene, formaldehyde, etc.), HC (THC, NMHC, NMOG, TOG, VOC), PM₁₀, (OC, EC, sulphate, brake, tire)</p>
Others	Emission inventory (kg, tonnes), emission rates (gr/veh. mile), fuel consumption
Type of EFs	Running exhaust, start exhaust, brake wear, tire wear, evaporation permeation, evaporation fuel vapour venting, evaporation fuel leaks, crankcase running exhaust, crankcase start exhaust, crankcase extended idle exhaust, refuelling displacement vapour loss, refuelling spillage loss, extended idle exhaust
Vehicle characteristics	
Vehicle category	Motorcycle, passenger car, passenger truck, light commercial truck, intercity bus, transit bus, school bus, refuse truck, single-unit short-haul truck, single-unit short-haul truck, motorhome, combination short-haul truck, combination long-haul truck.
Engine size	(n/a)
Weight class	(n/a)
Vehicle class	Source bin system
Fuel/ energy type	Gasoline, diesel, CNG, LNG, Ethanol (E85), Electricity
Emission Standard	<p>EPA standard: Tier I (released in 1994), Tier II (2004 – 2009), Tier III</p> <p>There is no differentiation of emission limit between diesel and gasoline (neither CARB nor EPA)</p>
Driving cycle	FTP75 (Federal Test Procedure)

To calculate emissions rate, MOVES is based on the modal model (operating mode) that can account for different driving conditions such as acceleration, cruising, deceleration, braking, idling under pre-defined vehicle speed ranges varying VSP. The methodology assumes that the

vehicle behaves the same way for pre-defined vehicle speed and power demand. MOVES includes different emission rate for each combination of source, age group and operation mode (see Figure 2-6).

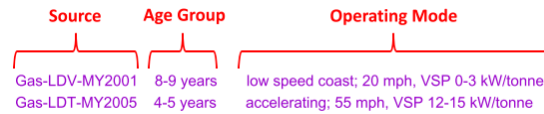

Figure 2-6: Illustration of the emission rate for each combination (EPA US 2011)

MOVES allows users to analyse the emissions at various scales (national, country and project) and various time aggregation levels (year, month, day and hour) with the different input of options at each scale and level. MOVES can also be used to generate the emissions factors for project-level analysis. Moreover, the user can choose the application type in the simulation, whether for inventory or emission rate purpose. Nowadays, MOVES has been used recently in the US as part of a research study to evaluate the policy scenario, such as evaluating intelligent transportation system (ITS) strategies. Table 2-7 provides an overview of MOVES.

EMFAC

EMFAC is an emission model developed by the California Air Research Board (CARB). The latest version of EMFAC is EMFAC 2021, replacing the early version of EMFAC 2017. This model mainly provides EFs and calculates scenario and project-level emissions for various regulatory requirements. However, the recent version also covers emission inventory which supports CARB’s planning and policy development. EMFAC is also developed and modified outside California. The EMFAC methodology is adopted to the local conditions (such as local vehicle fleet characteristics) of Hong Kong with a version of EMFAC-HK 2012 (HKEPD 2018).

In EMFAC, running exhaust emission rates are based on average vehicle travel speed. Introductory emission rates are derived from emissions tests performed under standard conditions such as temperature, driving cycle and fuel, adjusted for individual speed bins. An adjustment can be used at various temperatures, gasoline types and humidity (Demir et al. 2014). Table 2-8 provides an outline of EMFAC.

Table 2-8: EMFAC overview (Bai et al. 2008; CARB 2021)

Purpose	<ul style="list-style-type: none"> - Emission model for road transport operations - Emission inventory - Emission rates database - Policies scenario and project-level assessment
Historical development	<ul style="list-style-type: none"> • The version of EMFAC: <ul style="list-style-type: none"> ○ CT EMFAC in the early 1990s ○ EMFAC 2007, 2011, 2014, 2017 ○ EMFAC 2021 • Official website: http://www.arb.ca.gov/msei/modeling.htm
Type of program	
Generic type	Average speed model
Derivation of the EFs	Trip-based vehicle average speed (on bins mode) Dynamometer test data with speed corrections
Operational	Phyton and MySQL database since EMFAC 2021
Sample of case studies	Case study of a tunnel in Beirut, Lebanon (El-Fadel and Hashisho 2000) Case study of Hong Kong (HKEPD 2012, 2012)
Resolution	
Spatial	County, district, air basin, state of California and project (regional level)
Temporal	Various time aggregation levels (year, season, month, day); hourly emissions can be obtained directly by changing default activity data Analysis year: 1970 – 2060
Data entry	
County	Use of default data and specific county data (vehicle fleet and VMT distributions)
Project	Detailed local specific data such as : <ul style="list-style-type: none"> • Travel models (link characteristics, vehicle operation modes, vehicle fleet characteristics, speed distribution, road type, etc.) • Local sources (specific hourly temperature and relative humidity profiles, pre-defined inspection and maintenance programs or user-defined)
Derived from the transportation model	Volume or VTM (vehicle travelled miles), speed (average for each road link)
Other operational	(n/a)
Defined traffic situation	(n/a)
Pollutants/ outputs	(depends on simulation level)
Global pollutants	CO ₂ , CH ₄
Air pollutants	Regulated: CO, HC, NO _x , PM _{2.5} Other: SO _x , Pb, HC (THC, ROG, TOG, VOC), PM ₁₀ , PM ₃₀
Others	Emission inventory (kg, tonnes), emission rates (gr/veh. mile), fuel consumption
Type of EFs	Running exhaust, start exhaust, idle exhaust, diurnal, hot soak, resting loss, running loss, brake wear, tire wear.
Vehicle characteristics	
Vehicle category	Light duty auto, light duty truck, medium and heavy-duty truck, bus, motorcycle
Engine size	(n/a)
Weight class	(n/a)
Vehicle class	Source bin system
Fuel/ energy type	Gasoline, diesel, electricity
Emission Standard	EPA standard: Tier I (released in 1994), Tier II (2004 – 2009), Tier III (2014-now) There is no differentiation of emission limit between diesel and gasoline (neither CARB nor EPA)
Driving cycle	FTP75

HBEFA

INFRAS developed the first version of HBEFA 1.1 in 1995 on behalf of the Environmental Protection Agencies of Austria, Germany and Switzerland. The latest version of HBEFA 4.1 was introduced in August 2018. Currently, Sweden, Norway, France, the three initial countries, and the JRC (Joint Research Center – under the European Commission) support the recent version

of HBEFA. In 2014, HBEFA was localised and developed outside of Europe, the version called HBEFA China (Schmied et al. 2013; Sun et al. 2015). Table 2-9 provides an overview of HBEFA.

Table 2-9: HBEFA overview (Notter et al. 2019; Smit et al. 2014)

Purpose	- Public version: emission factors database - Expert version: emission model, emission inventory, input for air quality model
Historical development	A version of HBEFA: - (HBEFA 1.1) - Dec 1995 --> *DE, CH, AT ; (HBEFA 1.2) - Jan 1999 --> *DE, CH, AT ; - (HBEFA 2.1) - Feb 2004 --> *DE, CH, AT ; (HBEFA 3.1) - Jan 2010 --> *DE, CH, A, SE, N, FR (HBEFA 3.2) July 2014 - (HBEFA 3.3) April 2017 - (HBEFA 4.1) August 2018 - Official website: http://www.hbefa.net
Type of program	
Generic type	Aggregated emission factors (e.g. national inventories) Fleet + (instantaneous) emission model
Derivation of the EFs	- PHEM model validated with dynamometer test data - Traffic situation (qualitative assessment of driving conditions) - Travel speed
Operational	Build on MS Access application
The sample of case studies	- Localising the Handbook of Emission Factors for Road Transport to Chinese Cities Approach to adapt HBEFA to Chinese cities (Schmied et al. 2013) - Comparison HBEFA with emissions measurement in the Gubrist road tunnel, Switzerland (Colberg et al. 2005)
Resolution	
Spatial	Street-level (meso) + upwards Regional, national level: "coherence by aggregation."
Temporal	day level (per hour, but not second) yearly level: coherence by aggregation
Timeline	1990 - 2050
Data entry	
Derived from transport model	Volume or VKT (Vehicle kilometre travelled), speed (average for each road link), fleet mix, traffic flow
Fleet composition	Fleet (year, base case, age distribution, detail per sub-segment, mass engine, etc.)
Travel activity	VKT, distribution of VKT (urban, non-urban, motorway)
Defined traffic situation	EU: 276 traffic situations (by road type, speed limit, level of service, gradient)
Pollutants/ outputs	
Global pollutants	CO ₂ , CH ₄ , N ₂ O
Air pollutants	CO, HC, NO _x , PM, several components of HC (CH ₄ , NMHC, benzene <deduction from total HC>, Toluene <deduction from total HC>, Xylene <deduction from total HC>), NH ₃ , SO ₂ , NO ₂ , PN, PM for petrol, Pb (lead)
Others	Fuel consumption (litre/km)
Type of EFs	Hot, cold-start, evaporative, non-exhaust, air-conditioning
Vehicle characteristics	
Vehicle category	Two-wheeled vehicle, passenger car, light commercial vehicle, heavy-duty vehicle, urban bus, coach, motorcycle
Engine size	Variety
Weight class	Variety
Fuel/ energy type	Gasoline, diesel, CNG, LNG, ethanol (E85), electricity
Emission Standard	Euro standard
Driving cycle	Defined traffic situation

* country code: DE = Germany; CH = Switzerland; AT = Austria; SE = Sweden; N = Norway; FR = France

HBEFA public version is an EF database that provides specific EF per traffic activity (g/km) for different vehicle categories in various traffic situations. The real full version emission model is named "HBEFA expert version". The expert version provides the emission factor database, a fleet model, traffic activity module, and emissions calculation. Unfortunately, the accessibility of the full version of HBEFA is restricted only to specific institutions. Table 2-9 provides an overview of HBEFA.

The current version of HBEFA 4.1 delivers many or even most EFs from the new measurements. The database systems were collected from ARTEMIS inventory model, PHEM (emission factor model), previous HBEFA version or other models. Considered one of the most representative EFs databases in Europe, HBEFA is based on the European state-of-the-art vehicle categories and large databases. Table 2-10 illustrates the detailed approach of EFs calculation that defines different vehicle categories.

Table 2-10: Different models for different vehicle categories are used to produce EFs in HBEFA

Passenger cars	PHEM	EFs for passenger cars derived from PHEM emission model
	ARTEMIS	Cold start EFs based on EMPA
	COPERT IV	Evaporation EFs approach is adopted from COPERT IV based on country-specific input parameters
Light commercial vehicle	PHEM	EFs are adopted from PHEM model
Heavy goods vehicle	PHEM	EFs for HGVs and buses were calculated using PHEM model
	ARTEMIS	Number of measurements were conducted within the scope of international projects such as ARTEMIS, PARTICULATES and COST Action 349
	PARTICULATES	
	COST Action 349	
Motorcycles	ARTEMIS	The model of producing EFs was adapted similarly to passenger cars, and emission measurements were adjusted from ARTEMIS

The general methodological approach of HBEFA to develop emission factors is divided into two major stages (Figure 2-7), which are:

1. identifying the real-world driving pattern (traffic situations), and
2. generating reliable emission factors.

The first essential step defines the measurement of real-world driving patterns aiming to derive typical traffic situations. Therefore, approaches may be taken, such as using the global positioning system (GPS) devices to record driving behaviour by GPS tracking. The devices will record specific locations, times, speeds, and the elevation of different vehicle activities. To ensure reliability, the tracking should reflect the usual trip and regular drivers. The second step is the development of typical traffic situations based on measured traffic patterns. The new version of HBEFA illustrates clearly the traffic situation groups based on four dimensions: (1) areas (urban/rural); (2) road types (e.g. motorway, trunk road); (3) speed limit (e.g. 50 km/h); (4) level of services (free flow, heavy traffic, saturated, stop & go). Besides that, traffic situations are identified by average speed and acceleration (RPA – relative positive acceleration), deceleration, and percentage stop time.

To generate reliable EFs and engine maps, each traffic situation emission measurement is needed as a further consideration. Unfortunately, practical restrictions include the feasibility of measuring all 276 traffic situations and all vehicle types, which is costly and time-consuming. Therefore, the HBEFA approach uses a computer model as an underlying program (PHEM) to calculate EFs for different traffic situations. The computer model's emission tool is calibrated

with emission measurement based on (real world) driving cycles and generates the engine maps based on real-world measurement data. Furthermore, EFs are identified based on simulated engine maps.

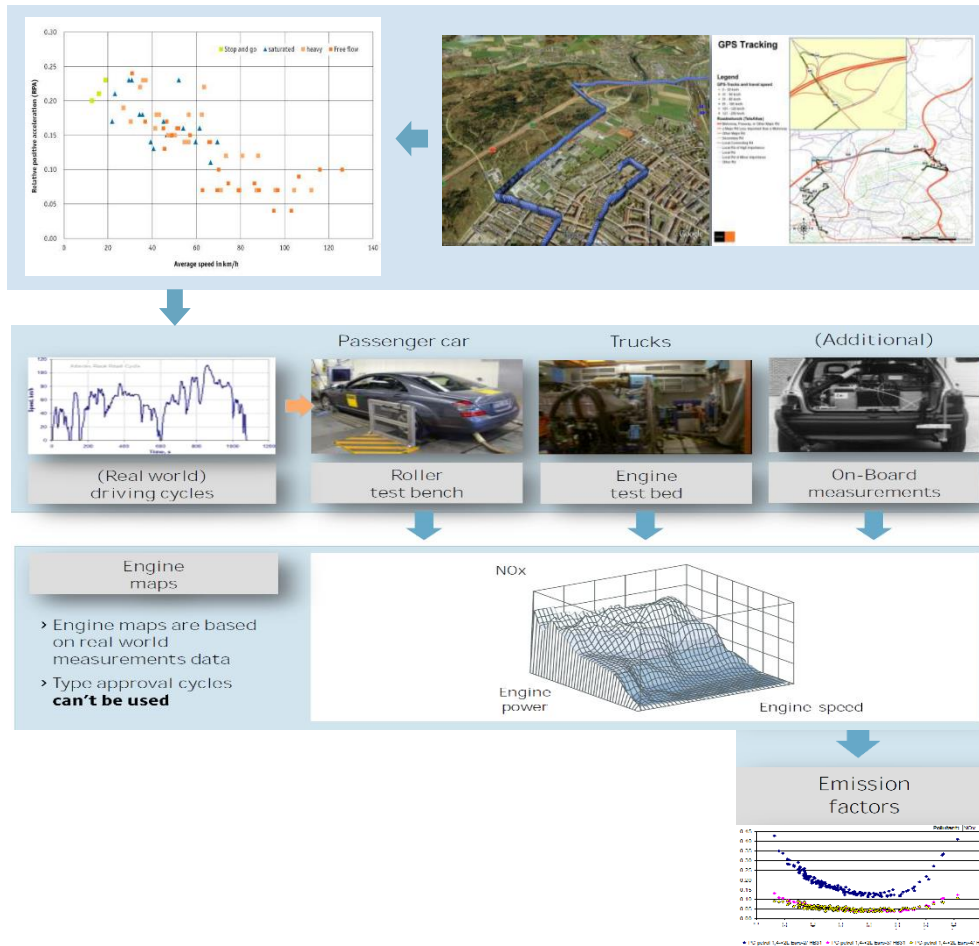

Figure 2-7: HBEFA methodological approach in generating EFs (Schmied 2014)

COPERT

COPERT is an emission tool designed to estimate air pollutants and GHG emissions from road transport. The tool is developed by EMISIA and the Laboratory of Applied Thermodynamics, coordinated by the European Environment Agency (EEA) under the European Topic Centre for Air Pollution and Climate Change Mitigation. The tool also offers the possibility of application in all European and several Asian countries.

COPERT was first released as “COPERT 85” in 1989 and continuously updated with a version of COPERT 5.4.3 released recently in September 2020. Until today, COPERT is still under further development. Recently, COPERT street-level application is available to capture a minimum temporal level of an hour compared to a year and a further detailed spatial level (EMISIA 2018).

The COPERT defines the total emissions as a product of activity data provided by the user and speed-dependent EFs that are developed empirically from multiple real-world tests on many urban drives. These driving cycles are not based on constant speed but involve a stop and go city traffic and suburban driving cycles (Barlow and Boulter 2009). The speed-dependent EFs curves are derived from the mean results of each distinct cycle. COPERT defines traffic situation by considering information about average speed on different street categories, such as urban (10-50km/h), rural (40-80km/h) and highway (70-130km/h), and no other specific traffic situations are available. As an illustration of an average speed function, Figure 2-8 describes an example of NO_x emission for a specific car type.

The model determines four emission estimations: (1) hot emissions, (2) cold-start emissions, (3) fuel evaporation emissions and (4) non-exhaust PM emissions (i.e. tyre, brake emissions). The application has been developed for the annual national and regional inventories. Nevertheless, the methodology can also be applied in higher resolution with a sufficient degree of certainty and accuracy. An example might be an hour's temporal resolution and a spatial resolution of 1x1 km² (Kousoulidou et al. 2009).

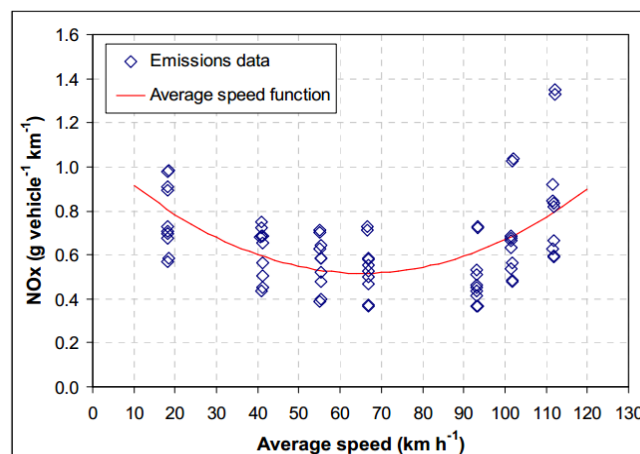

Figure 2-8: Average speed emission function for NO_x emission from Euro 3 diesel cars <2.0 litres (Barlow and Boulter 2009)

An initial study done by (Smit and Ntziachristos 2012) to adopt COPERT 4 into COPERT Australia 1 reflects local Australian conditions. The results were highly variable, where the models showed quite similar predictions in some cases but quite different in others. The mean differences in the speed range of 10-90 km/h vary from +46% to +113%. The difference was mainly ascribed to differences in the Australian fleet characteristics, fuel composition, driving behaviour and local conditions. These results confirm the need for an Australian model. Therefore, since 2014 COPERT Australia is adopted and developed by cooperation between EMISIA and the Queensland Department of Science, Information Technology, Innovation and Arts (EMISA 2018). An overview of COPERT is described in Table 2-11.

Table 2-11: COPERT overview (Smit et al. 2014)

Purpose	<ul style="list-style-type: none"> - Emission inventory - Database for EFs and traffic activity data - Air quality impact assessment
Historical development	<ul style="list-style-type: none"> - A version of COPERT: <ul style="list-style-type: none"> ▪ COPERT 85, 1989; 1990, 1993 ▪ COPERT II, 1997 ▪ COPERT III, 1999 ▪ COPERT 4, Vers.1, Dec 2005 – Vers. 11.4, Sep 2016 ▪ COPERT 5, Vers.5.0.1, Jan 2015 – Vers.5.4.3, Sep 2020 ▪ COPET Street level, since Jan 2015 - Official website: http://www.emisia.com/copert/General.html
Type of program	
Generic Type	Average speed approach
Derivation of the EFs	Speed-dependent emission factors; it is developed empirically from multiple real-world tests on many urban drives
Operational	MS-Office for Windows application (data stored in ACCESS file à SQL since COPERT 5)
The sample of case studies	<p><u>Application area :</u></p> <ul style="list-style-type: none"> - A country case of Tunisia (Nanni et al. 2010) - A city case of Kumasi city, Ghana (Agyemang-Bonsu et al. 2010); Bucharest (Nanni et al. 2011) - COPERT Australia (Smit and Ntziachristos 2012) <p><u>Comparison:</u></p> <ul style="list-style-type: none"> - VERSIT + and COPERT IV (Smit et al. 2007) - HBEFA 3.1 and COPERT IV in a case city of Madrid, Spain (Borge et al. 2012) <p><u>Validation:</u></p> <ul style="list-style-type: none"> - The use of PEMS compared to the COPERT emission factors (Kousoulidou et al. 2009) <p><u>Policy scenarios:</u></p> <ul style="list-style-type: none"> - Speed management policies in Europe (Int Paris et al. 2011)
Resolution	
Spatial	National, regional and local scale
Temporal	Yearly (possible to daily), timeline 1970-2050
Data entry	
Fleet composition	Vehicle fleet (category, fuel type, engine, vehicle technology)
Activity	Number of vehicles (veh.), distance travelled (km/period of inventory)
Traffic situation	Urban (10-50km/h), rural (40-80 km/h), highway (70-130 km/h)
Derived from the transportation model	Volume or VKT (Vehicle kilometre travelled), speed (average for each road link)
Pollutants/ outputs	
Global pollutants	CO ₂ , CH ₄ , N ₂ O
Air pollutants	<p>regulated (CO, NO_x, VOC, PM)</p> <p>unregulated (N₂O, NH₃, SO₂, NMVOC speciation ...)</p> <p>other (PM, heavy metals, ...)</p> <p>It also provides speciation for NO/NO₂, elemental carbon and organic matter of PM and non-methane VOCs, including PAHs and POPs.</p>
Others	Fuel Consumption (litre/km)
Type of EFs	<ul style="list-style-type: none"> - Hot & cold emissions: technology /emission standard, mean travelling speed (km/h) - Cold emissions: ambient temperature (Celsius), mean trip distance (km) - Evaporation: tank and canister size, vehicle mileage (absorption potential), temperature variation, fuel vapour pressure (kPa), fuel tank fill level, parking time distribution, trip duration
Vehicle characteristics	
Vehicle category	Including more than 240 individual vehicle types, including: passenger car, light-duty vehicle, heavy-duty vehicle, buses, mopeds and motorcycle
Fuel/ energy type	Gasoline, diesel, CNG, biofuel and alternative fuels
Emission Standard	Euro standard
Driving cycle	European driving cycle

PHEM

In the beginning, PHEM was developed for HDV EFs, but at this time passenger car is covered with data collaboration from COST 346 projects and ARTEMIS. PHEM estimates emissions from a vehicle (CO, CO₂, HC, NO_x and PM) for every second and fuel consumptions based on engine speed and instantaneous engine power demand during the driving pattern specified by the user (Haberl et al. 2014). In Europe, PHEM is used as an underlying model of several more aggregate emission models such as COPERT, HBEFA and ARTEMIS (Schmied 2013).

As illustrated in Figure 2-9, the model uses the interpolation methodology of fuel consumption and emissions from steady-state emission maps, being defined by given driving cycles per second. In addition, transient correction functions and the gear shift model are introduced to ensure accuracy. Transient engine maps are three-dimensional graphs covering engine power (rated power 100%), engine speed 'n-norm' (ranging from 0%-100%) and the emission values given in (g/h)/kW rated power (Haberl et al. 2014).

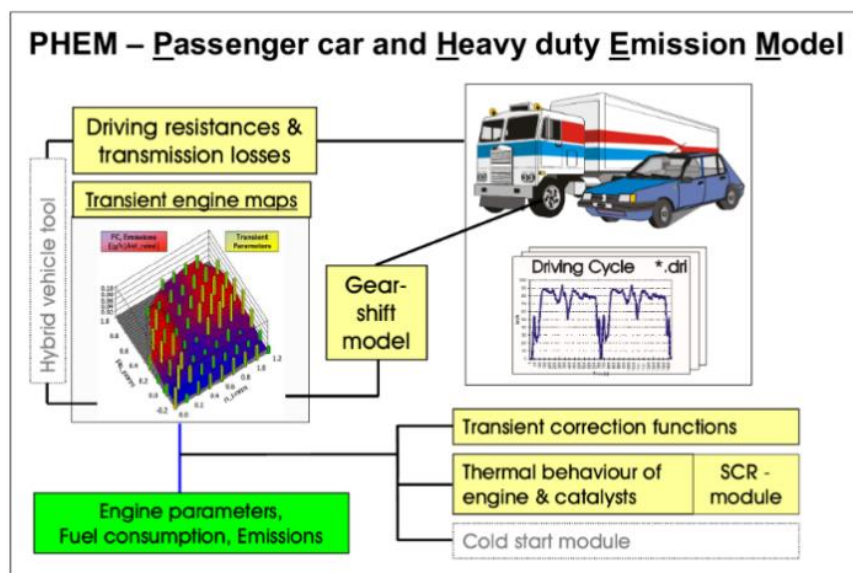

Figure 2-9: Model structure of PHEM (Hausberger et al. 2005)

According to (Hausberger et al. 2003a; Hausberger et al. 2011) the engine power demand can be determined as follows:

$$P_{engine} = P_{rolling\ resistance} + P_{air\ resistance} + P_{acceleration} + P_{road\ gradient} + P_{transmission\ losses} + P_{auxiliaries}$$

Equation 2-2

Each of the power components is a function of dynamic variables such as speed and acceleration and many static variables such as vehicle mass, loading, wheel dimension, road gradient and other coefficients. The actual engine speed is a function of vehicle speed, the wheel diameter and the transmission ratio of the axle and the gearbox, as shown below:

$$n = v \times 60 \times i_{axle} \times i_{gear} \times \frac{1}{D_{wheel} \times \pi}$$

Equation 2-3

where:

- n is the engine speed (rpm),
- v is vehicle speed (m/s),
- i_{axle} is the transmission ratio of the axle (-),
- i_{gear} is the transmission ratio of actual gear (-),
- D_{wheel} is the diameter of the wheel (m)

Furthermore, PHEM allows users to define vehicle characteristics in detail, although the default values are given for ‘average’ vehicles, which comply with European emission legislation. An overview of PHEM is described in Table 2-12

Table 2-12: PHEM overview (Hausberger 2017; Hausberger et al. 2003b)

Purpose	Provide accurate EFs
Vehicle type	Heavy goods vehicle: rigid heavy goods vehicle (8 classes), artic. heavy goods vehicle (6 classes), coaches (2 classes), buses (3 classes). All vehicles Pre-Euro I to Euro VI Passenger car: Individual vehicles or average pre-Euro to Euro VI diesel and petrol
Type of program	
Generic type	Instantaneous (power-based) emissions model
Derivation of EFs	Engine power demand over the driving cycle (as well as vehicle operating)
Operational	Not yet clear/described explicitly in the reference
Type of case studies	Individual vehicle test
Resolution	
Spatial	Microscopic scale (single street) + upwards
Temporal	By second
Data entry	
Fleet composition	Passenger car and heavy goods vehicle: vehicle data
Traffic Situation	Passenger car: engine speed, gear shift, driving cycle, gradient Heavy goods vehicle: engine speed, gear shift, driving cycle, gradient, the full load curve
Coverage pollutants	
Global pollutants (gram/km)	CO ₂
Air pollutants (Gram/km)	CO, HC, NO _x , PM and PN
Other	Fuel consumption (litre/km) → initially all output in 1 Hz engine power
Type of EFs	Hot and cold-start
Motivation	The model is expected to be developed as a capable model that accurately simulates EFs for all types of heavy goods vehicles and passenger cars with reliable and relevant influencers such as driving behaviour, road gradient, vehicle loads, etc.
Commissioner	(n/a)
Developer	TU Graz
Stakeholder	(n/a)
Version	(n/a)

3 Vehicle Emissions Model Selection

Traffic emissions modelling is a crucial tool, especially in an urban area, to understand transportation activities and monitor their impact on air pollutants and greenhouse gas (GHG) emissions. It helps policymakers and other stakeholders to make efficient and effective policies for pursuing environmental targets. However, existing vehicle emissions models have been mainly developed and applied in developed countries and cities according to their traffic conditions and other local characteristics. For this reason, it is essential to identify the critical criteria for selecting the most appropriate emissions model for a specific application.

This chapter aims to determine and review selection criteria based on an extensive and in-depth review of research and reports on existing traffic emissions models and their applications. It is followed by a proposed analytical process for selecting a suitable traffic emissions model for an application. Finally, a real case of Singapore's city-state is examined according to the identified criteria, and the process of selecting a proper emissions model is proposed.

3.1 Introduction

Various traffic emissions models have been developed in the last few decades, as discussed in Section 2.7. Moreover, numerous pieces of literature have been published on traffic emission modelling and its application. There is no international agreement suggesting that specific emissions models are the best for all situations (Smit et al. 2006; Mahmud and Arem 2008). None of the emissions models can provide details and a comprehensive calculation covering all aspects of traffic emissions at all scales (Smit et al. 2009). Only some emissions models (e.g. HBEFA) can cover nearly all scales, and these are always subject to specific application objectives (Hickman et al. 2009; Duduta, Bishins 2010).

Furthermore, emissions estimation results vary significantly depending on the method chosen (Duduta, Bishins 2010). For this reason, various emissions models are available for a specific purpose. However, they tend to have different intentions, characteristics regarding scope, input data (collection), approaches, and output

3.2 Criteria influencing emissions model selection

Literature on the traffic emissions models and their applications has been thoroughly pragmatically reviewed, involving numerous sources over the last twenty years, including technical reports, journal papers, conference and seminar proceedings, and technical books. However, only limited sources discuss precisely the criteria influencing the selection of a suitable emissions model. Several studies and literature reviews were carried out, such as (Duduta, Bishins 2010; Smit 2006), explaining each criterion of emissions model selection explicitly as a function of different interrelated criteria. The rest of the studies merely discussed

the criterion implicitly in general terms or through case studies. Figure 3-1 lists the most relevant studies and literature according to emission modelling selection criteria. The criteria are divided into internal and external criteria. The following section explains the selection criteria for the vehicle emissions model in detail.

Table 3-1: Identification of the selection criteria for emission modelling

No	Publication	Type of publication	Criteria																	
			Internal				External													
							Local conditions									Practicability				
			1	2	3	4	1	2	3	4	5	6	7	8	9	1	2	3	4	5
1	(Andre et al. 2006)	TR																		
2	(Atjay 2005)	D																		
3	(Boulter 2012)	TR																		
4	(Chidambaram 2011)	JP																		
5	(Coelho et al. 2014)	JP																		
6	(Huo et al. 2011)	JP																		
7	(Latham et al. 2000)	TR																		
8	(Mahmod and Arem 2008)	TP																		
9	(Misra et al. 2013)	JP																		
10	(Ong et al. 2011)	JP																		
11	(Smit 2006)	D																		
12	(Smit and McBroom 2009b)	TP																		
13	(Soylu 2007)	JP																		
14	(Spence et al. 2009)	TR																		
15	(Trachet and Madireddy 2010)	TR																		
16	(Wang, McGlinchy 2009)	CP																		

Notes:

Reference type: Technical report (TR); Technical paper (TP); Conference paper (CP); Journal paper (JP); Dissertation (D);

Criteria:

- Internal criteria: 1. Objective; 2. Resolution; 3. Approach; 4. Data;

- External criteria:

- local condition: 1. Fleet composition; 2. Vehicle classification; 3. Driving behaviour; 4. Fuel characteristic; 5. Emission regulation; 6. Meteorological;

- 7. Altitude; 8. Use of auxiliary equipment; 9. Close correspondence with an existing traffic model

- practicability: 1. Budget; 2. Institutional issue; 3. Expert; 4. Up-to-date model; 5. User-friendliness 6. Comprehensiveness/ availability

3.2.1 Internal criteria

The internal criteria consist of several steps; (1) determination of the modelling objective; (2) finding the appropriate resolution; (3) identification of potential emissions model approaches; and (4) data availability checking. The details are discussed next.

(1) Determination of the modelling objective

The transport-related emissions models began in the late 1960s in North America and a bit later in the 1970s in some European countries (Park et al. 2016; Spence et al. 2009). Since then, various transport emissions models have been developed for different application purposes at various levels of analysis. There are, of course, alternative ways to structure the emissions model based on the application purpose. Investigation and classification of the objectives have been done and discussed by several studies (Smit 2006; Boulter 2012; Keller 2007; Andre et al. 2006). The objectives of emissions estimation are described in Figure 3-1 and summarised below:

- (a) The development of emissions inventory to achieve a comprehensive air quality and climate change action plan. It covers the total emissions of specific air pollutants and GHG emissions at a time and spatial resolutions. The stakeholders can use the outcome to understand the emissions' contribution to overall transport activities.

In many developed countries, especially in Europe, an emissions inventory methodology for air pollution and GHG emissions has been developed within the framework of two protocols: the CLRTAP and the UNFCCC. The related countries are subject to international obligations concerning the regular monitoring and reporting of air pollutants and GHG emissions within the two protocols. This trend is also extended to other parts of the world as legally binding or voluntary. Therefore, many manuals and inventories have been developed to harmonise the inventory system. Some example manuals and inventories are the IPCC Guidelines for National Greenhouse Gas Inventories (Waldron et al. 2006) and EMEP/EEA air pollutant emission inventory guidebook 2013 (Ntziachristos and Samaras 2013). The latest version of COPERT 5.4 (Gkatzoflias et al. 2012) is currently integrated into the EMEP/EEA methodology for emissions estimation used by most European countries to compile their national emissions inventory.

This objective's typical scales are aggregate scales such as national, provincial, regional, or urban area levels (Duduta, Bishins 2010; Smit 2006; Keller 2007; Barlow 2013; Trachet and Madireddy 2010). However, the study case's boundary should be clearly defined, such as the transport activity within a region or a city.

- (b) The evaluation of transport scenarios. The scenario can be a single or a combination of programmes (e.g. city emission reduction plan), projects (e.g. low emission zone) and measures (e.g. individual action plan such as traffic management) over a time period.

Nowadays, transport planning concerns not only investment and congestion issues but also environmental impact. In developing countries, this kind of objective is also used to propose additional international and local funding to accelerate sustainable urban transport implementation on behalf of the climate change scheme. Examples of this scheme are the Clean Development Mechanism (CDM) for Transmilenio Bus Rapid Transport (BRT) system in Bogota (Duduta, Bishins 2010; Gruetter 2007) and the National Appropriate Mitigation Actions (NAMAs) for Sustainable Urban Transport in Indonesia (SUTRI) (Henkel et al. 2014). This objective requires specific prioritisation of particular emission types and their spatial scales and the current actions (trend, analysis, forecasting). This objective's typical application scale varies from the link, neighbourhood, network, city, and up to a regional level. Moreover, the scale issue can be conditioned based on the government's priorities for monitoring emissions and mitigation actions (Boulter 2012).

(c) Detailed analysis of emission impact caused by local traffic measures at a finer temporal and spatial scale. This objective is an extension of the second objective but on a smaller scale. Some examples of this objective are implementing dynamic traffic management at an intersection (Bigazzi et al. 2010) and evaluating the introduction of high occupancy lanes and eco-lanes (Fontes et al. 2014). This objective's typical application is a more detailed spatial and temporal resolution such as neighbourhood, intersection, link, and even an individual vehicle level, requiring numerous data details.

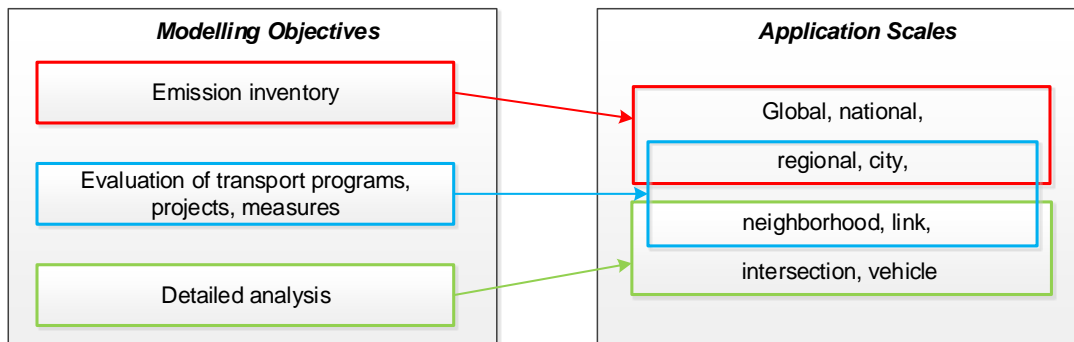

Figure 3-1: Typical transport emissions model application based on the desired objectives

(2) Finding the appropriate resolution

Traffic emission modelling applications can be performed and varied significantly based on the spatial and temporal resolution (Atjay 2005; Mahmud and Arem 2008), depending on the modelling objectives and the scale of interest (Smit et al. 2009). The spatial scale of the modelling can be assessed at an intersection, link, neighbourhood, city, country region, national, world region or even at a global level, whereas the time scale considered can range from a second up to an annual level.

Concerning detailing combinations of temporal and spatial scales, it is necessary to understand pollutant characteristics. Fuel combustion produces air pollutants that cause varying effects on a geographical scale, from local to global. Studies carried out by (Hickman et al. 2009; Faiz et al. 1996; Van der Meer 2007) categorised the pollutants into three classifications based on the scale effects: local, regional and global (Table 3-2). Local pollutants, such as CO, NO_x, PM, SO₂, and HC, affect public health and the quality of life on a local scale (e.g. links, urban areas). Regionally, some pollutants such as CO, NO_x, NH₃, HC, affect plants and the built environment due to their dispersion, deposition, and chemical transformation (photochemical reactions, acid rain), and the spread of their impact through photochemical reaction products (e.g. secondary sulphate, ozone). These pollutants affect public health in the long term.

Furthermore, GHG emissions such as CO₂, CH₄ and N₂O affect the climate and deplete the stratospheric ozone layer. In a summary, Table 3-2 describes the various pollutant effects.

There is no standard optimum spatial scale of resolution for emissions calculation. It depends on the intended pollutants and their effects in a specific application.

Table 3-2: Pollutants effects caused by transport activities (Hickman et al. 2009)

	PM	NH ₃	SO ₂	NO _x	HC	CO	CH ₄	CO ₂	N ₂ O
LOCAL (health, quality of life)	■					■			
REGIONAL		■	■	■	■	■			
Acidification		■	■	■					
Photochemical				■	■	■			
GLOBAL				■	■	■	■	■	■
Greenhouse effect (indirectly)				■	■	■	■	■	■
Greenhouse effect (directly)							■	■	■
Stratospheric ozone layer									■

Theoretically, a combination of spatial and temporal scales should be sufficient to assess air pollutants and emissions. However, additional factors must still be considered, such as the application objective, the time period available to monitor the pollutants, and the scale of the pollutant's effects.

The local pollutants (e.g. CO, SO₂, NO_x, PM) produced from combustion directly affect human health (Dora et al. 2011). Therefore, they need to be assessed daily or even hourly within an application to provide reliable dispersion modelling input. This level of analysis further allows to estimate the ambient pollutant's concentration and develop other strategies to reduce air pollution. Moreover, the air pollution effects and health guidelines can also be considered at the temporal scale. A higher-level temporal scale would also benefit some local pollutants in further scientific research and consideration of health impact. The development of such a grander temporal scale for local pollutants is possible using so-called aggregation. However, the aggregation should acknowledge different traffic and environment behaviours such as peak hours, day and night, working days, weekends and holidays. On the other side, measuring global pollutants such as CO₂ on an hourly basis is unnecessary since CO₂ is known to have long-term cumulative effects related to climate change. Therefore, an annual average CO₂ calculation is adequate for fundamental research analysis or an international protocol report.

Understandably, more granulated application scales require more complex and comprehensive calculation approaches. The following section explores further details of identifying suitable emissions calculation methods.

(3) Identification of potential emissions model approaches

As mentioned in section 2.6.1, various classification structures exist for the existing emission models, although some overlap slightly. A variety of considerations can shape the classification, including congestions (Smit et al. 2008), the aggregation level and the level of detail (Treiber and Kesting 2013), the treatment of kinematic effects (e.g. the effect of different speed-time profiles) (Smit et al. 2006; Mahmud and Arem 2008) and the generic type or the operational basis (Mahmud and Arem 2008; Boulter et al. 2007a; Boulter et al. 2009; Wismans et al. 2011; Spence et al. 2009; Hickman et al. 2009; Wang and McGlinchy 2009a). A summary of the emissions model classification is listed in Table 3-3.

Table 3-3: Emissions model classification

1	The consideration of congestion (Smit et al. 2008)	Type A: the model requires driving pattern as input	MEASURE, VERSIT +
		Type B: the model generates driving pattern data as part of the emission modelling processes	TEE
		Type C: the model with incorporated driving pattern in the development phase of the model	MOBILE, EMFAC, COPERT
2	The aggregation level and the level of detail (Treiber and Kesting 2013)	Macroscopic models <ul style="list-style-type: none"> - Area-wide models - Average speed models - Traffic situation models - Traffic variables models 	COPERT, MOBILE, EMFAC, HBEFA, ARTEMIS, MOBILE, TEE
		Microscopic models <ul style="list-style-type: none"> - Speed-profile models - Modal emission models 	CHEM, PHEM
3	The treatment of kinematic effects (e.g. the effect of different speed-time profiles) (Smit et al. 2006; Mahmud and Arem 2008)	Type A: the least complex models with a few discrete predefined traffic situations (e.g. urban driving, rural driving, highway driving)	The Dutch method (calculating method for national emission levels)
		Type B: as type A with a large number of predefined traffic situations	HBEFA
		Type C: the (unvaried) regression model where the emission is calculated using continuous emission factor	COPERT
		Type D: the most complex models where the traffic situations are measured using driving pattern data	VERSIT+, EMPA
4	The generic type or the operational basis (Mahmud and Arem 2008; Boulter et al. 2007a; Boulter et al. 2009; Wismans et al. 2011; Spence et al. 2009; Hickman et al. 2009; Wang and McGlinchy 2009a)	Aggregated emission factor models	NAEI, EMFAC
		Average speed models	COPERT, MOBILE, ARTEMIS
		Traffic situation models	HBEFA, ARTEMIS
		Regression driving mode models	VERSIT+, UROPOL,
		Instantaneous models	CHEM, PHEM, MODEM, DGV
5	Transportation data specification (Elkafoury et al. 2013)	Static models/ top-down/ macro scale <ul style="list-style-type: none"> - Aggregated emission factor models - Average speed models 	NAEI, MOBILE, ARC's VEPM
		Dynamic models/ bottom-up/ micro scale <ul style="list-style-type: none"> - Traffic situations models - Instantaneous models 	HBEFA, ARTEMIS, PHEM, MOVES

The emissions modelling approach represented below is based on the generic type, which is classified into five types with an increasing level of complexity:

- **Aggregated emission factor (EF) models** (e.g. NAEI, MOBILE) estimate the emissions based on the aggregated EF and vehicle kilometre travelled (VKT) in an application area. The EFs are calculated from the mean values of measurement or laboratory tests to

represent a particular type of vehicle in a given general driving cycle. The VKT is typically disaggregated into at least passenger cars and HDVs. These models deliver emissions and global fuel consumption in an investigated area.

Moreover, these models are usually applied at a significant strategic level (e.g. regional, state) and annual temporal resolution (Smit et al. 2009; Waldron et al. 2006). This method is also in line with the IPCC methodology for Tier 1 (Waldron et al. 2006), whereas the yearly distance travelled per vehicle is typically derived from national statistics, and a single default EF is usually used for the estimation of total area emissions. This approach is easy to use for national inventories, but it cannot be used for scenario evaluation. The motor vehicle emissions inventory was estimated for the metropolitan area of Mexico City (Schifter et al. 2005) and the megacity of Delhi (Nagpure et al. 2013) using this approach.

- **Average speed models** (e.g. COPERT, MOBILE, EMFAC) are based on the principle that EFs for specific pollutant and vehicle types are a function of a mean average speed in a trip network area. The VKT is normally disaggregated into several vehicle classes, and it can be obtained from macroscopic transport models and national or regional statistic data. The model output is the number of emissions.

The average speed models are often used for medium and large-scale emissions estimation (Atjay 2005), for instance, at the regional level (Smit et al. 2009; Duduta, Bishins 2010), metropolitan area and city-scale (Duduta, Bishins 2010; Mensink et al. 2000b). Moreover, it is usually connected to existing macroscopic transport models or traffic demand models such as VISUM, SATURN, and EMME2. However, the approach can also be applied to a higher resolution with a sufficient degree of certainty and accuracy. Examples of a higher temporal resolution are the compilation of urban emissions inventories with a temporal resolution of an hour and a spatial resolution of $1 \times 1 \text{ km}^2$ (Borge et al. 2012), and some streets as well as road segments in the Antwerp area of $20 \times 20 \text{ km}$ (Mensink et al. 2000a).

While acknowledged as frequently used emissions models (Smit 2006, Wismans et al. 2011; Elkafoury et al. 2013), these models have the disadvantage of not accommodating essential driving combinations modes in a real-time speed profile. In fact, the high fluctuation of speed which is described in a real-time speed profile might have the same value for average travel speed, but significantly different EF (Hickman et al. 2009; Spence et al. 2009; Boulter et al. 2007a; Int Panis et al. 2006; Ahn and Rakha 2008). Moreover, this approach is a less helpful indicator for the new generation vehicles (Wang and McGlinchy 2009a) and less reliable for determining the effects of traffic jams in an urban area (Treiber and Kesting 2013). Nevertheless, these models are easy to use, given that the required data was generally available.

- **Traffic situation models** (e.g. HBEFA, ARTEMIS) calculate the emissions as a function of discrete traffic situations. Traffic situations are qualitatively and quantitatively defined according to the area, functional road types, level of service, and different speed limits. These models require VKT and average speed as input data per desired traffic situation. The EF is defined per vehicle category in a defined traffic situation. The necessary traffic data can be derived from traffic demands and route assignment models.

The traffic situation model has been used extensively to develop urban emissions inventory, especially at the city area level (Smit et al. 2006; Mahmud and Arem 2008). Moreover, the scale can also range from street to regional, national level, or aggregation of EFs from the street to the upper levels (Wang and McGlinchy 2009a) with a time scale from hourly to yearly levels (Keller et al. 2009). However, a disadvantage of these models is that they need detailed statistics about speed and analogous traffic situations (Elkafoury et al. 2013). Furthermore, the user must relate the application condition to how the traffic situations are defined in the model since there are no universally accepted definitions for traffic situations. This issue may lead to inconsistencies in the interpretation of different users (Boulter et al. 2009). Nevertheless, a study carried out by (Hueglin et al. 2006) indicated a good agreement between the EFs from HBEFA and the ambient air quality analysis in Switzerland's motorway application.

- **Multiple regression models** (e.g. VERSIT+) use a set of statistical models for specific vehicle categories that have been incorporated using multiple linear regression analysis. The models are based on the test of a large number of vehicles in different driving cycle variables (e.g. average speed, idle time, and positive kinetic energy) at high time resolution (seconds to minutes) (Ligterink and De lange 2009; Trachet and Madireddy 2010). The models generate emissions for specific vehicle classes, which represent an average or a standard vehicle. The vehicle category, vehicle positions and speed for all vehicles in a network are considered model inputs. These data can be collected from a measurement, a Global Positioning System (GPS) equipment or a microscopic traffic model such as PARAMICS and VISSIM.

An example of the multiple regression model is VERSIT+. This type of model can be applied at different application levels, from a local street to a national level (Smit et al. 2007; Ligterink and Lange 2008; Mahmud and Arem 2008). This emissions model has been used in the Netherlands for many years to calculate road vehicle emissions under various conditions. The model can since recently accommodate traffic issues' direct evaluation impact such as local effects of traffic management measures, congestion, and fleet rejuvenation (Ligterink and De lange 2009). Furthermore, a study completed by (Madireddy et al. 2011) indicated the integrated approach of PARAMICS as a microscopic traffic model and VERSIT+

emissions model to examine the effect of traffic management measures (speed limit and traffic light coordination) in an area of Antwerp. However, due to the complexity and sensitivity of data set handling and many driving cycles used for testing, this model is not simple to execute.

- **Instantaneous models** (e.g. PHEM, MOVES, PAP) also refer to the modal model, continuous, on-line and microscale models (Atjay 2005; Haan and Keller 2000). The EFs of these models are a function of a specific vehicle operation mode encountered during the trip based on the speed and acceleration or the engine power demand. These models need speed profiles of single vehicles at high temporal resolution (of a few seconds or less). As output, these models deliver instantaneous EFs of a single vehicle of a particular class.

The development of instantaneous models began in the 1990s. This approach is believed to provide more accurate emissions calculation at the local scale, project level or small network by relating the emission rates to the vehicle operation during a series of short time intervals (often in a second). However, some significant complications are linked to this approach (Boulter et al. 2007a; Boulter and Mccrae 2007b; Joumard 1999), such as the need for complex data (e.g. vehicle operation, road geometry and atmospheric temperature). This approach's application is mainly combined with traffic models (Smit 2006), especially the microscopic traffic model. Integrated microscopic traffic and emissions modelling approaches have been analysed and documented (Boulter et al. 2007a). Other examples of the interesting applications can be found as follows: VISSIM-PHEM (Boulter and Mccrae 2007b), VISSIM-MODEM (Boulter and Mccrae 2007b), VISSIM-CHEM (Chen and Yu 2007; Nam et al. 2003; Noland and Quddus 2006; Stathopoulos and Noland 2003), PARAMICS-CHEM (Misra et al. 2013), EMME-CHEM (Amirjamshidi et al. 2013), PARAMICS-MOVES (Xie et al. 2012), and PARAMICS-MODEM (Joumard 1999).

Figure 3-2 summarises the explanation above and proposes an initial screening step to determine the potential emissions model approaches based on the scale needed for the application purpose and the desired output scale. (Smit and McBroom 2009a) claimed every single model had been developed to its objective and the appropriate extent of the application, which means a different level of detail and accuracy. It should be highlighted that there might be a considerable degree of overlap among different modelling approaches once the modelling objective is defined and the approximate application scale is decided. For instance, the traffic situation model possibly covers a broader area regarding temporal and spatial scale, where some of the coverage scales overlap with other approaches such as multiple linear regression, average speed and aggregate EF models. For the initial screening, more than one potential emissions model approaches could be taken into

account. The steps elaborated next will help to identify the correct emissions model approaches by checking the input data availability.

Temporal/spatial	second	minute	hour	day	week	month	season	year
intersection	Instantaneous							
link							Traffic Situation	
neighborhood							Multilinear Regression	
city							Average Speed	
regional (in a country)							Aggregated Emission Factor	
national								
global								

Figure 3-2: Emissions model approaches based on the scale required for modelling application purposes

(4) Checking the data availability

The total mobile source emissions are a function of a specific EF and traffic activity. The definition of traffic activity and the derivation of EFs can be extended to some advanced modelling approaches. The essential data requirements for mobile source emissions modelling are summarised in Table 3-4. The summary table has been developed using the information presented in sections 3.1.1.- 3.1.3. The different levels of data needs are explained based on the modelling approach. Moreover, three levels of traffic data availability have been differentiated: (1) readily available in general statistics; (2) commonly available; (3) rarely available.

The demand for input data for emissions modelling can be gathered from various sources such as the official statistic, traffic census, field data (survey), traffic model and new information technology. Typically, the complexity of input data increases along with the complexity of network scale, temporal scale (Barth et al. 2000), and a modelling approach (Smit et al. 2009; Mahmood and Arem 2008; Smit 2006). For example, collecting the spatial and temporal data related to vehicle travel activity on its entire networks using the trajectory data (e.g. GPS) significantly benefits from instantaneous emissions analysis. Still, this requires considerable time, budget, and human resources.

Table 3-4: Data requirement of emission modelling approaches

Fuel sales	x					1
Basic vehicle categorization	x					1
Basic VKT	x					1
Vehicle population	x	x	x			1
Specific VKT – vehicle type based		x	x			2
VKT distribution		x	x			2
Fleet composition		x	x	x	x	2
Average speed		x	x			2
Speed limit			x			2
Level of service			x			2
Road type		x	x			2
Typical road gradient			x			2
Level of service (LOS)			x			2
Traffic situation			x			2
Typical driving condition		x	x			2
Fuel quality		x	x			2
Typical temperature and humidity		x	x			1
Separate fleet model				x	x	2
Vehicle loading				x	x	2
Local Traffic count					x	3
Link length					x	2
Engine operation					x	3
Vehicle speed				x	x	3
Vehicle acceleration				x	x	3
Detailed road gradient					x	3
Detailed temperature and humidity		x	x		x	2

Abbreviation used: Aggregated emission factor model (A), average speed model (AS), traffic situation model (TS), multiple regression model (MR), instantaneous model (I), vehicle kilometre travelled (VKT)

Data availability: 1=readily available in general statistics; 2= commonly available; 3 = rarely available

The fleet composition consists of vehicle categorisation and fleet information. The vehicle category covers vehicle type, propulsion type, engine type, reduction technologies, and emission standards, whereas fleet information includes vehicle mix and vehicle growth in a specific period. The vehicle categorisation for aggregated EFs model is usually disaggregated into passenger car and heavy-duty vehicle, whereas further models are typically disaggregated into more accurate vehicle categorisation and fleet information.

Both specific traffic activity data and EF are very closely related. The way an emission model translates, both terms are also different regarding the data's level of detail. Traffic activity data such as VKT by trip type and vehicle type, link profile, traffic flow, and speed profile can be obtained from empirical relationships derived from different sources such as traffic censuses, official statistics, field surveys and other statistical or study data. To fill the gap in essential traffic data requirements, macroscopic transport or microscopic traffic models are often used. While more complex models are more precise and adaptable, they require more comprehensive input data. For example, a detailed model such as an instantaneous model requires specific data to produce the engine map, such as speed and acceleration input, driving cycle, gradient, and vehicle and engine parameters.

One of the uncertainties and most significant challenges in emissions modelling are the EFs. The accuracy of emission estimation depends on the aggregate level of the EFs approach. For instance, at a superficial level using an aggregated EF model, a single EF derived from a laboratory test is being utilised to represent a broad range category of vehicle and general traffic conditions (urban roads, rural roads, and highways). For further detail, the approach incorporates the speed and driving dynamics into the estimation. The speed and the driving dynamics can be obtained from driving cycle data or microscopic traffic data, and then certain traffic situations can be defined qualitatively based on the road types and traffic conditions (e.g. urban free flow stop and go, congested). However, the lack of input data may restrict the selected emissions model approaches, making the model application less reliable (Smit and McBroom 2009b).

3.2.2 External criteria

(1) Local conditions

The local conditions reflect the local characteristics of an application related to the meteorological issues and existing policies' local implementation. It covers meteorology (such as humidity, ambient temperature, and altitude), emission standards, fuel characteristics (Wang and McGlinchy 2009a) and typical fleet composition. The estimation of evaporative emissions depends on the climatic case area. For instance, it is also essential to consider evaporative emissions in a tropical urban area with higher humidity and ambient temperature.

Identifying a typical fleet composition in an application area is essential considering that most emissions models have been actively developed and implemented in Europe and the US. Therefore, the types available fleet model is usually referred to as the European or US fleet. On one hand, the European fleet tends to have a considerable share of diesel cars and smaller engine types of passenger cars. On the other hand, the US fleet is likely to have a majority share of petrol cars and larger engine types. Therefore, the typical fleet composition, emissions standard and driving behaviour in an application area should have a certain degree of similarities to the applied emissions model. Likewise, it is not easy to adjust existing overseas emissions models in Australia since the emission datasets, typical fleet characteristics, and driving behaviour do not reflect the Australian condition (Smit and McBroom, 2009). Therefore, a dedicated Australian version of COPERT using COPERT methodology was developed and calibrated with Australian vehicles test to overcome this issue (Smit and Nziachristos 2013).

(2) Practicability

Practicability refers to the level of convenience to apply the emissions model in practice. It can be translated into total time, budget, human resources, and efforts to develop and maintain the

emissions model. Considering the implementation, the practicability criterion is more important compared to the local conditions criterion.

In most developing countries and cities, gathering available and comprehensive data and developing an emissions model is always challenging, mainly due to the complex nature of their low quality and less detailed data collection, data reporting system and limited budget. Cost-related issues must be taken into account (Keller 2007). Therefore, strong cooperation with related institutions is strongly recommended since the data and the developed model should be handed over, maintained, and updated regularly. The recommended emissions model should also be comprehensive, accurate, understandable and easy to use by the institution officers (Smit and McBroom 2009a). Besides, collaboration with the experts (such as emissions model developers) (Boulter 2012) is also good to ensure the prediction's compatibility, accuracy, and feasibility. In the end, the level of uncertainty in a study case should be sufficiently identified for further model developments.

The emissions model should technically offer specific emissions (such as CO, HC, PM_x, CO₂) or at least emission types (cold start and evaporative emissions) addressed by the application purpose. A sustainable emissions model can be easily identified by a commonly used and up-to-date model in practice. The availability of the model is also often discussed in research, report, journals and conferences. Among the existing emissions models, the MOVES, HBEFA, COPERT, and EMFAC are the most up-to-date. However, the most evolved large-scale emissions models are MOVES and COPERT (Trachet and Madireddy 2010).

3.3 The proposed process of selecting a suitable emissions model

The researcher analyses and summarises the emissions model selection criteria into two main criteria: internal and external criteria. Figure 3-3 shows a simple analytical process of selecting an appropriate emission model for an application based on identified individual criteria previously listed in Section 3.2. Literature on the traffic emissions models and their applications has been thoroughly pragmatically reviewed, involving numerous sources over the last twenty years, including technical reports, journal papers, conference and seminar proceedings, and technical books. However, only limited sources discuss precisely the criteria influencing the selection of a suitable emissions model. Several studies and literature reviews were carried out, such as (Duduta, Bishins 2010; Smit 2006) explaining each criterion of emissions model selection explicitly as a function of different interrelated criteria. The rest of the studies merely discussed the criterion implicitly in general terms or through case studies. Table 3-1 lists the most relevant studies and literature according to emissions modelling selection criteria. The criteria are divided into internal and external criteria. The following section explains the selection criteria for the vehicle emissions model in detail.

The internal criteria are the fundamental criteria. They are divided into four sub-criteria sequencing steps, from identifying objectives to considering data availability. The application’s purpose must be clearly defined as an early step in defining internal criteria. A clear objective will distinguish the appropriate resolution of the application area. Second, the resolution can be precisely defined on a spatial and temporal scale. Third, the emission modelling approach can be easily determined once the expected resolution is identified. The complexity of the modelling methods is usually in line with the expected resolution. Next, data availability needs to be checked as a requirement to perform the selected modelling method. If the data availability does not meet the condition, the selected modelling method cannot be used accurately. If needed data cannot be collected, a step back to a less sophisticated approach is needed to be selected, followed by checking data availability. Finally, once the data is reasonably available, a suitable emissions model is selected to pursue the main objective.

The external criteria discuss the case study’s environment-related issues. They cover the practicability and the local condition criteria such as budget, institutional and meteorological issues. The external criteria are interconnected with each other along with the sequential steps of the internal criteria. The practicability mainly relates to the emissions model approach and data availability addressing several limitations such as budget and human resources. The local condition influences the whole sequence of the internal criteria. The external criteria need to be considered since many emission models were developed and applied in developed countries. Combining these internal and external criteria fetches different perspectives from the practical and local perspective, especially for the implementation in developing countries and cities with limited availability and quality of data and resources.

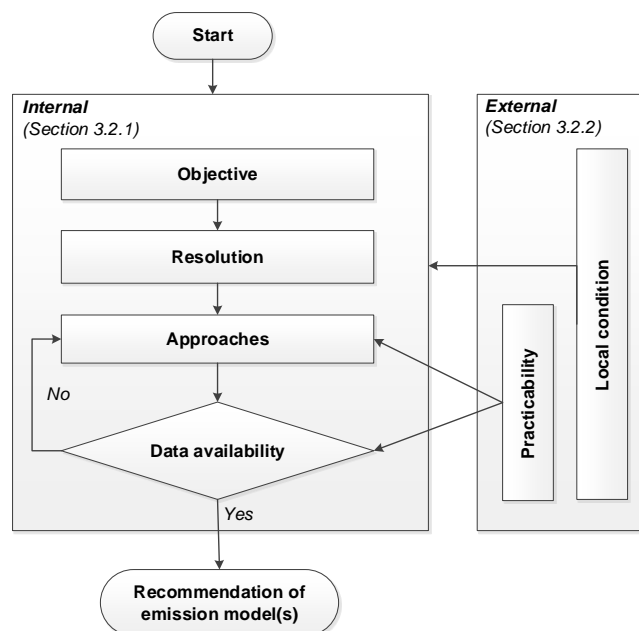

Figure 3-3: The proposed analytical process for the selection criteria of a suitable emissions model

3.4 Case of Singapore

As a developed city-state in South-East Asia and one of the world's most competitive countries, Singapore contributes approximately 0.11% of global air pollutant emissions (NEA 2018). Singapore is also well known for implementing environmentally sustainable transport policies. However, Singapore has not yet publicly established vehicle emissions models to support the accurate emissions prediction from road transport activities. The emissions model can also help the government monitor the effectiveness of transport mitigation and set a goal to reduce transport pollutant emissions. Therefore, it is critical and reasonable to compare (as described in Section 3.2.1) and select an appropriate model (as explained in Sections 3.2 and 3.3) for quick and straightforward application in Singapore. A suitable emissions model for Singapore can be interpreted with the criteria mentioned in (Section 3.2) following the selection process mentioned in Figure 3-3.

The objective of emission modelling is to develop a road transport emissions inventory for Singapore, as such comprehensive publications are not yet available. An emission inventory is defined here as a data set of road transport quantified pollutant emissions within a specific area in a year or other period of time. Singapore's spatial scale suits the city-state scale with a temporal scale of a minimum of a year to reach the emissions inventory goal. The intended emissions cover air pollutants and global CO₂ emissions.

Considering the declared modelling objective and spatial-temporal scale, possible methodological approaches described in Figure 3-3 are aggregated EFs, average speed, multilinear regression and traffic situation models. In order to select the correct approaches, it is essential to check the data availability. Aggregated EF approach uses the input data such as total fuel use, total activity data, and general EFs. In comparison, more specific data and information are needed for more comprehensive approaches.

Table 3-5 lists transport-related emissions data availability in Singapore. Most of the data is available from the LTA, with specific data collected but not made public. In terms of vehicle population, the categorisation of vehicles is quite detailed. LTA categorises motor vehicles into vehicle type, engine size, weight, fuel type, age, and make (manufacturer). Still, the categorisation of the technology of emission standards is missing. Traffic activity data defined in an annual VKT is also available, but a typical Singapore driving cycle for all vehicles is not available for all types of vehicles. A study was done by (Ho et al. 2014) to define the Singapore driving cycle but only for PCs, whereas a specific emissions inventory requires driving cycles for all vehicle types. In addition, EFs are not yet available; therefore, EFs defined by the emissions model can be used temporarily until the Singapore EFs are established.

Table 3-5: Data available for Singapore

Annual VKT	(√)	√	√	√	(√)	√	
Vehicle speed	-	(√)	-	-	(√)	-	
Vehicle population							
- Vehicle type	√	√	√	√	√	√	
- Engine size	√	√	√	√	√	√	
- Weight	√	√	√	√	√	√	
- Fuel/technology	√	√	√	√	√	√	
- Age	√	√	√	√	√	√	
- Make (manufacturer)	√	√	√	√	√	√	
- Emission standard	-	-	-	-	-	-	
Regular I&M	√*	√*	√*	√*	√*	√*	
Vehicle occupancy	(√)	(√)	(√)	-	√*	-	
Driving cycle	√*	√*	-	-	-	-	
Emission factor (EF)	-	-	-	-	-	-	
Fuel sale	(√)						Only petrol and diesel
Transport model	√*	√*	√*	√*	√*	√*	LTA
Emissions monitoring	√*						
Local traffic count data	√*						Survey on-site or from related studies or institution

Note: (√) = available in general terms, √* = available but not for public, PC = passenger car, MC = Motorcycle

In terms of external criteria, the city-state of Singapore has a relatively clear traffic boundary within the island itself. The meteorological condition is highly humid with a tropical temperature throughout the year. Therefore, the share of evaporative emissions is relatively high. The emission standards follow the European emission standards, also with a typical European fleet. Overall, the data is generally updated due to institutional solid coordination and performance.

Considering all the criteria, especially the data availability and some local conditions, the recommendation is to estimate an emission inventory using the COPERT model. In terms of practicability, the COPERT can be performed reasonably in terms of time, with limited human resources, while offering support from external experts to estimate the emissions. It is essential to start estimating the emissions using a simple method according to the quality and availability of data, at least to set a baseline. With time, the methods could be improved to reduce the uncertainties of emissions estimation.

Further fleet model development will be explored in (Chapter 4), the applicability and predictability of Singapore's selected emission model will be carried out using the COPERT (Chapter 5). While the EFs will be validated on real-world measurements (e.g. tunnel study) (Chapter 6).

3.5 Conclusions

This chapter presents a comprehensive range of criteria that aid the policy (decision) makers and other related stakeholders in screening and selecting the appropriate emissions model in an application. The criteria to consider the appropriate emissions model include the internal criteria (modelling objective, resolution, approach, and data availability) and external criteria (local condition and practicability). These criteria provide an overview of existing emissions models, the influence factors in traffic emission, and indicate considerations in selecting the

suitable emissions model. These criteria can be used for initial discussions with related stakeholders as the basis for strategic planning and decisions.

The emissions model selection criteria are based on the pragmatic literature review involving numerous sources and lessons learnt from different applications over the last twenty years. Some literature explicitly mentioned the criteria in an application's particular case, and some explained implicitly general cases. Further research of the criteria developed quantitatively is possible, for instance, by scientific and reasonable scoring scales of each criterion under specific circumstances.

The recommended emissions model selection process has been adopted for a confirmed case of Singapore. Considering the city-scale context, data availability, and other local conditions, the COPERT emissions model is recommended. In Chapter 4, the Singapore vehicle fleet model is established. The application of COPERT for the city-state of Singapore is explained in Chapter 5. Since COPERT is considered a macroscopic model and developed for specific European countries, emissions prediction might deviate mainly from the EFs. Therefore, real-world measurements such as in a tunnel are taken and discussed in Chapter 6 to identify the deviation.

4 Vehicle Fleet in Singapore

This chapter discusses the Singapore road vehicle fleet, including traffic-related data and other local characteristics. Vehicle fleet modelling is a crucial tool to identify the dynamics of vehicle development and traffic activities on the road, which can be used for further emissions estimation and to see the effectiveness of relevant policies at a macroscopic level. This chapter's main objective is to generate a categorisation of the fleet characteristics and its traffic activities. The step is needed to estimate air pollutants and CO₂ emissions in Chapter 5 and future emission reduction scenarios in Chapter 7.

4.1 Introduction

The vehicle fleet model is a practical way to understand the change of vehicle stocks over a timeline. It can also be used to analyse the impact of related policies in a country or at a regional level. The fleet composition and how it is used may differ significantly in fleet composition and use from one country to another, depending on, e.g., the economic situation of the region, the urbanisation level, and cultural differences influencing consumer choice (Smokers and Rensma 2006).

The Singapore vehicle fleet model is an independent (not as a part of the emissions model) user-friendly tool operated with Microsoft Excel. It is developed by the researcher to maximise the transparency, accuracy and accessibility of the methodology, data, assumptions, and results. Several evidence lines were used to develop a vehicle fleet model mainly based on the statistical data inputs from publicly available data sources.

One of the primary sources of public data is LTA (LTA 2019b). The LTA of Singapore annually publishes current information on land transport statistics, transport infrastructure, traffic matters, public transport, and motor vehicle facts. Besides, Singapore's data.gov.sg is a central institute responsible for state data in various sectors. This source serves as a good foundation for data collection harmonisation. Secondary sources mainly were gathered from previous related studies. Table 4-1 explains the data availability, the sources, and the quality of the data.

Table 4-1: Input data, quality, and their respective sources

1	Vehicle population	1	(LTA 2019a)
2	Vehicle classification - Age - Fuel - Engine capacity - Emission standard	2	(LTA 2019a) (LTA 2019a) (LTA 2019a) not available
3	VKT	3	(Data.gov.sg 2018)
4	Average speed	2	(Data.gov.sg 2016)
5	Vehicle ownership	2	(LTA 2019a)

Note: *1= very good, 2=good, 3=poor, 4=very poor

Numerous vehicle fleet models have been established, although their applications differ according to the targeted research. Most of the models link to vehicle stock development, vehicle use, emissions estimation, and energy consumption. The vehicle fleet model is usually included as a sub-module in some comprehensive transport emission models, like HBEFA, TREMOD and LIPASTO. However, the sub-module may not be easy to use, and sometimes the parameters do not correspond to a specific area and local conditions.

A study by (Wei and Cheah 2014) examined road vehicle fleet evolution in Singapore from 1998-2013 to determine the projected fleet model by 2030 and estimate GHG emissions. However, the authors could have contributed to a more detailed analysis. For example, they still treated all vehicles projection under the mode of ICEs, which were not reliable for Singapore's current condition with some penetration of new alternative fuels and advanced vehicles such as EVs. Besides, the projection of GHG emissions used a single EF for a general type of vehicle (e.g., car, bus, good vehicle, and motorcycle). The result was imprecise since only the share of vehicle type GHG emissions contribution (%) was indicated.

4.2 Methodology

The motor vehicle data is available in sufficient detail for the various fleet segments but with some limitations. Vehicle population data is available based on the segment (vehicle type and VQS - vehicle quota system) and specific sub-segment classification (vehicle age, vehicle manufacturer, engine size, weight, or type of fuel used) as seen in Figure 4-1. However, there is no correlation among those sub-segments. Still, emissions quantifications require a clear correlation between vehicle sub-segments. Therefore, some secondary data from the previous related studies and some technical data from different research projects were used to form the desired emissions model's expected correlation.

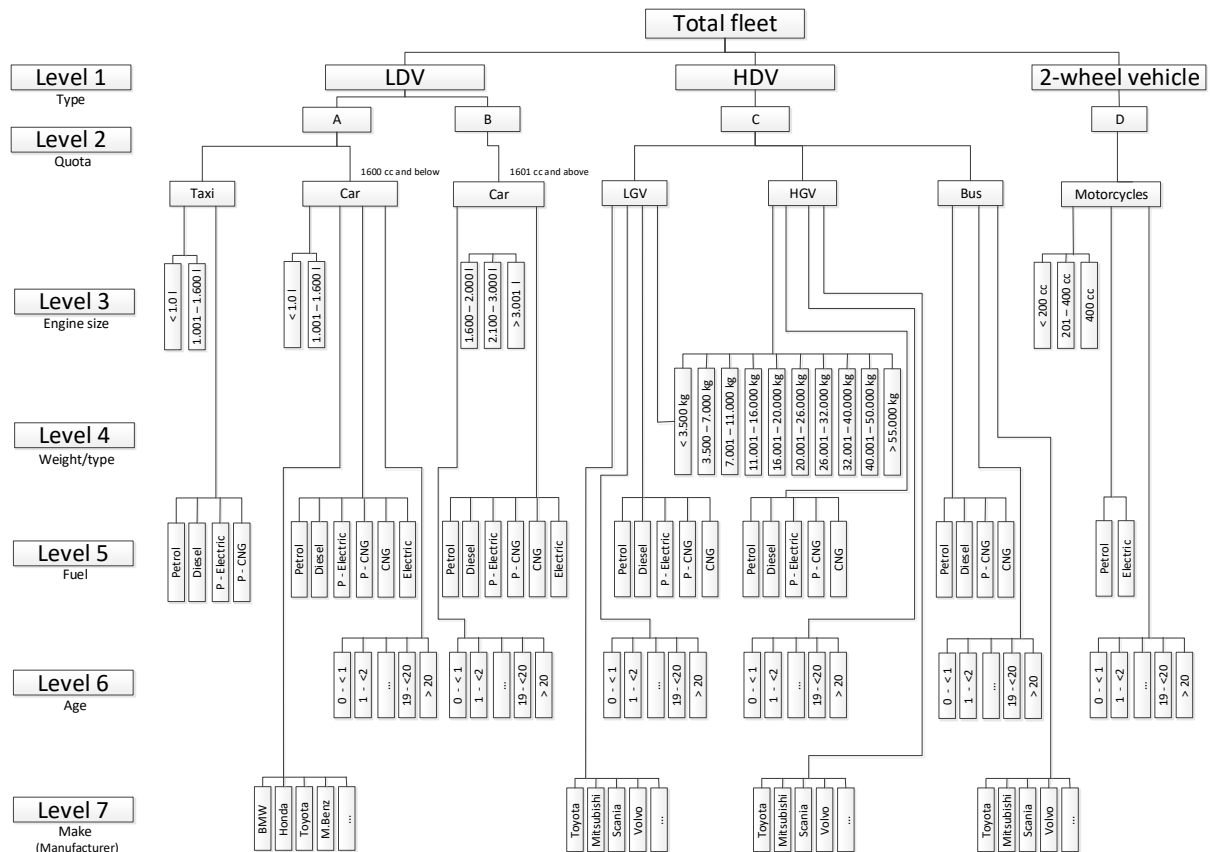

Figure 4-1: Vehicle population data availability by sub-segments

4.3 Primary information for the vehicle fleet model

In Singapore, vehicle population and fleet characteristics are strongly affected by a string of transportation management policies such as vehicle ownership control. Vehicle ownership control includes fiscal measures to moderate the motor vehicle population's growth, such as VQS (see Appendix A for the summary of the fiscal measures). With the introduction of the VQS in 1990, the government set an annual vehicle growth rate (VGR). It started at 3% in 1990 and went down gradually to 1.5% in 2009, 1% in 2012, to 0.5% in 2013 to control the vehicle population's growth due to the limited land supply. A further strict vehicle growth policy was implemented from February 2015 onwards, with the growth rate set at 0.25% per annum (LTA 2013a). Furthermore, in October 2017, the LTA announced to cut the growth rate at 0% per annum for all private cars and motorcycle categories, but not for the goods vehicles and buses. This change started in February 2018 as the government steered the state towards becoming a car-lite society.

In Singapore, motor vehicles are divided into five main categories: (1) Cars & station wagons, (2) Taxis, (3) Motorcycles & scooters, (4) Goods & other vehicles, and (5) Buses. However, the researcher further classifies the vehicles into the sub-specific classification to match the

emissions calculation (see Table 4-2). Also, it is necessary to divide the vehicle type according to their general traffic activities (e.g. VKT).

Table 4-2: Motor vehicle categorisation and its assumption

Cars & station-wagons	Passenger cars (PC)	PCs include private, company, tuition, and off-peak cars
	Private hire cars (PHC)	PHCs include self-driven and chauffeur cars
Taxis	Taxis (T)	Taxis (T)
Motorcycles & scooters	Motorcycles (MC)	MCs include MCs and scooters
Goods & other vehicles	Light-duty vehicles (LDV)	LDVs include GVPs and LGVs
	Heavy-duty vehicles (HDV)	HDVs include HGVs and VHGVs
Buses	Public buses (PB)	Public busses assumed as omnibuses
	Coach (C)	Coaches include school, private, private hire busses, and excursion buses

Abbreviations: GVPs = Goods-cum-Passenger Vehicles, LGVs = Light-Goods Vehicles, HGVs = Heavy-Goods Vehicles, and VHGVs = Very Heavy-Goods Vehicles

According to Table 4-2, PCs are assumed to comprise private cars, company cars, tuition cars, rental cars, and off-peak cars, whereas taxis and PHCs are categorised as passenger car types but separately simulated in COPERT. Taxis have significant higher mileage than passenger cars, and most of them use diesel as fuel, whereas PHCs are assumed to have the same fuel or technology as PCs but have extra kilometres travelled. It is assumed that coaches are intended for minibuses, school buses, private buses, private hire buses and excursion buses, while omnibuses address the whole type of public transport buses operated by four registered public transport companies in Singapore.

An illustration of the vehicle population development according to vehicle type and growth rate is described in Figure 4-2 (see Appendix B for more details). There are nearly one million vehicles on the road. The annual average vehicle growth rate sharply increased from 2004 and peaked at 6.5% in 2007. Then, from 2007 onwards, the vehicle growth rate continuously decreased to -1.66% in 2015. From 2007, the vehicle population decreased mainly because of the stringent vehicle growth rate policy. The vehicle population slowly increased since 2017, mainly due to the gradual enhancement of public bus services and demand for PHCs.

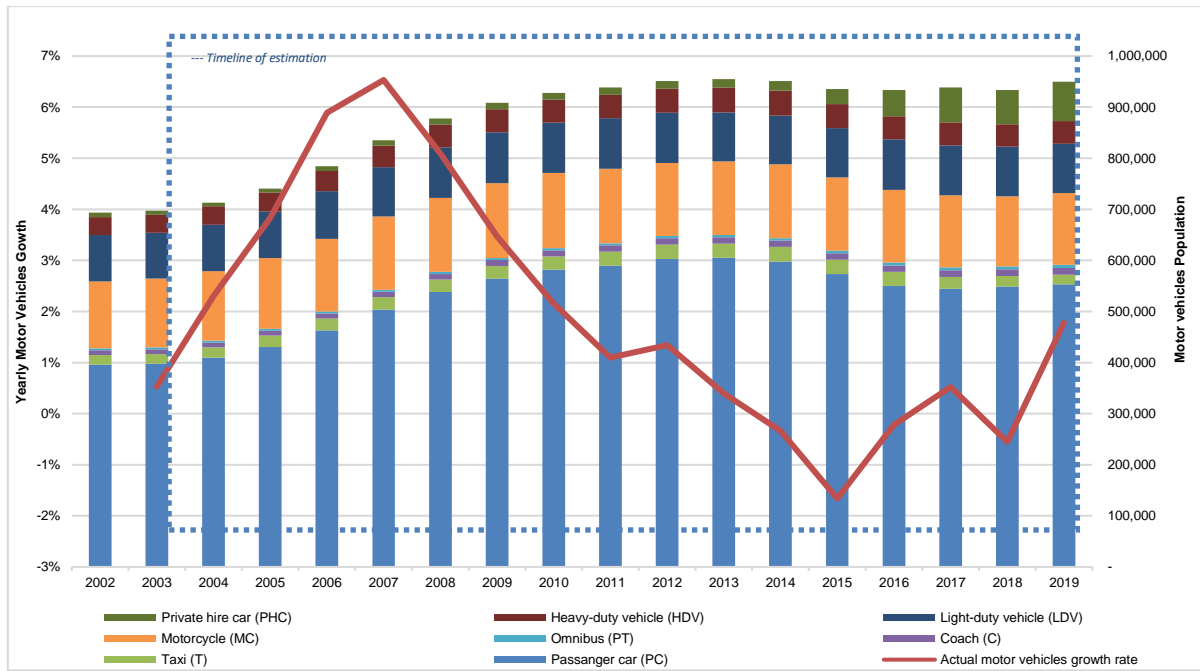

Figure 4-2: Vehicle population, fleet composition and its annual growth rate

From a population of nearly one million vehicles in 2019, around 66% of those are PCs and PHCs (Figure 4-3). One of the most critical highlights in vehicle share is the progressive development of PHCs. Since Uber and Grab entered the road in 2013, the number of PHCs soared by nearly five times, from 16,396 units in 2013 to 77,141 units in 2019. The share of PHCs in the total vehicle population increased in 2013-2019 from 2% to 8%.

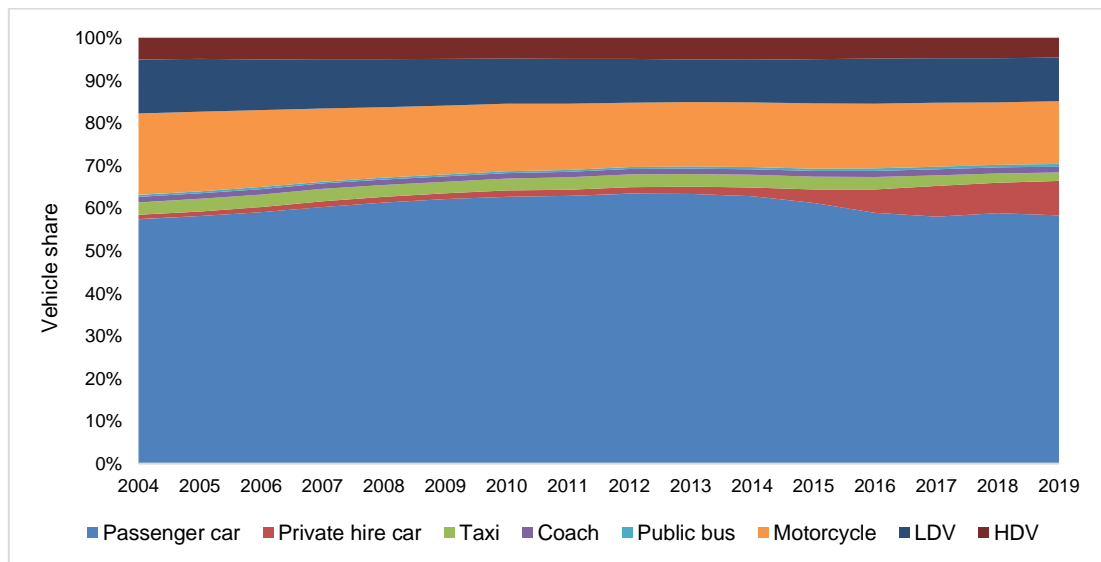

Figure 4-3: Vehicle share by categorisation

Simultaneously, PCs and taxis shares declined from 63% to 58% and 3% to 2%. So, it is an apparent battle for rides in the trend from PCs and taxis to PHCs. MCs also present a significant share of the total vehicle population, with approximately 15%. However, vehicle share does not

significantly impact emissions contribution unless the vehicle shares and VKT are in line. VKT will be discussed in detail in section 4.5.2.

4.4 Vehicle fleet classification

4.4.1 Vehicle fleet by fuel/technology

Alternative engine technology plays an essential role in the environment and human health. Table 4-3 provides an overview of available fuel or technology in various vehicle types in Singapore in 2019. A positive direction is seen towards EVs, in almost every vehicle type.

Table 4-3: Summary of vehicle type/technology/fuel combinations in Singapore

		ICE			Hybrid		PHEV		EV
		G	D	CNG	G-CNG	G	D	G	
Passenger car	PC	✓	✓		✓	✓	✓	✓	✓
	PHC	✓	✓			✓	✓		✓
Taxi	Taxi	✓	✓	✓	✓				✓
MCs & scooter	MC	✓	✓						✓
LDV & HDV	LDV	✓	✓	✓	✓	✓	✓		✓
	HDV								
Bus	Public bus		✓	✓	✓		✓		✓
	Coach	✓	✓				✓		

In the last few years, alternative energy sources for PCs, such as petrol-electric, petrol-CNG, diesel-electric and electric, rose by 1%. The distribution of PHCs by fuel and technology is assumed to follow that of the PCs.

In contrast to PCs, taxis mainly use diesel. In 2004, 99% of all taxis in Singapore ran on diesel (see Figure 4-4 for PCs and taxi fuel/technology share and Figure 4-5 and Figure 4-6 for the other vehicle types). By 2019, diesel taxis' share dropped to about 50% being replaced by petrol-electric technology and EVs.

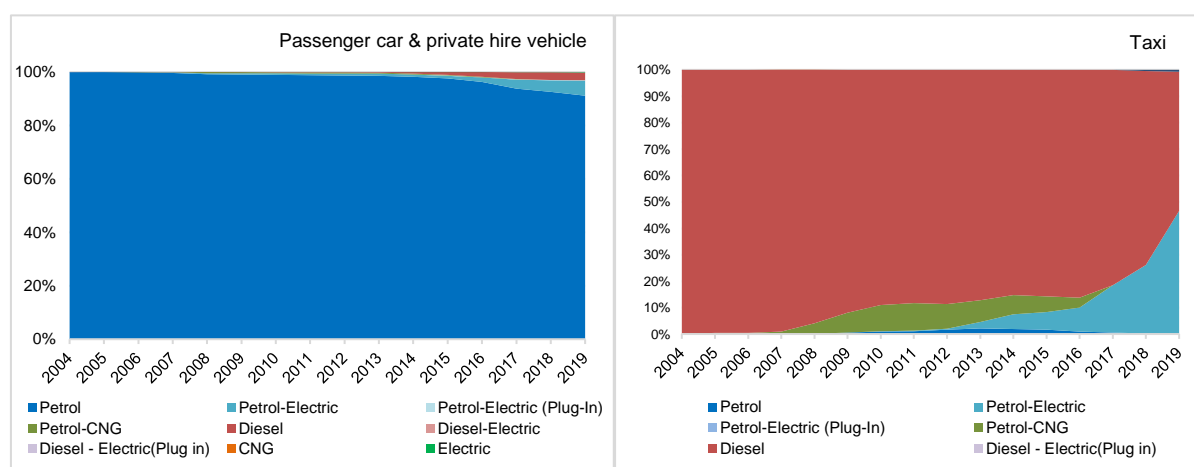

Figure 4-4: PCs and taxis share by fuel/technology

Petrol is mainly used in MCs. Only a minor share of electric MCs is available on the road. In 2019, only two units of electric MCs amongst 140,398 units were registered in Singapore. This number is neglected for an emission inventory purpose but still has a potential for future electrification development.

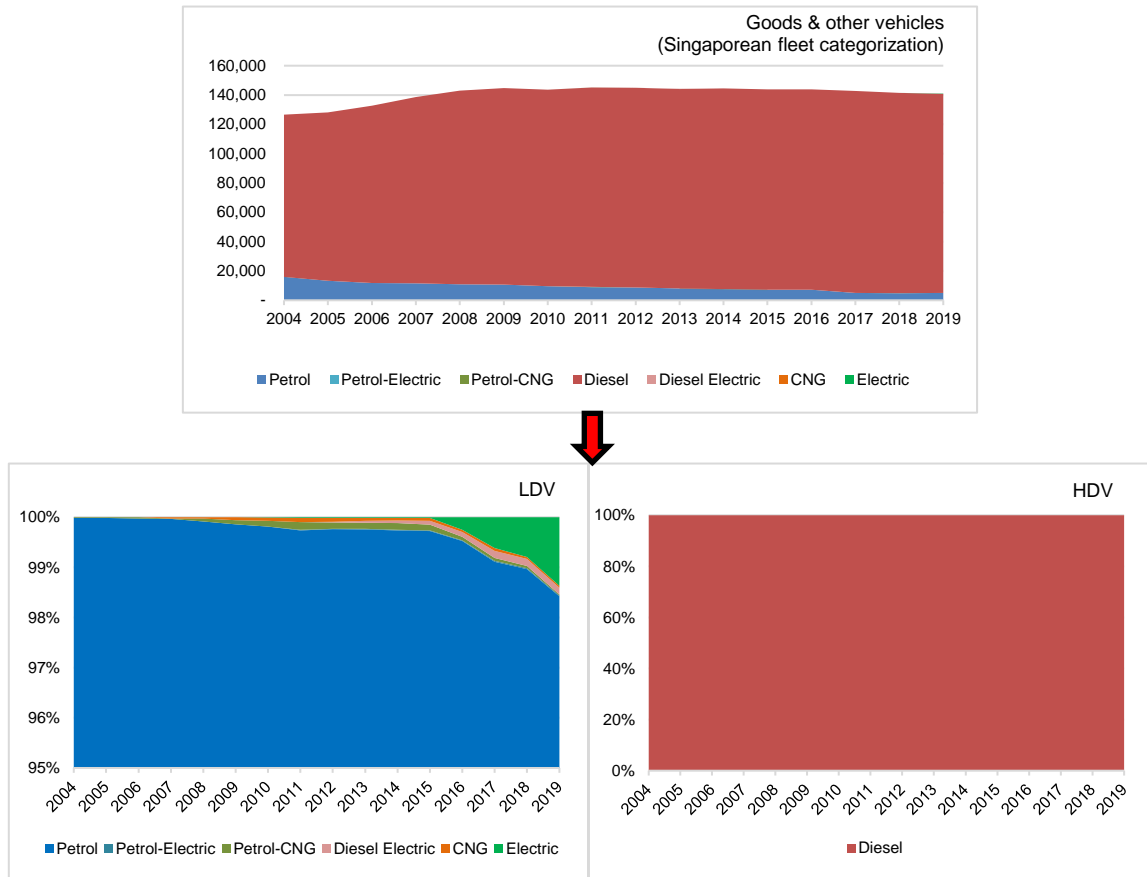

Figure 4-5: LDVs and HDVs share by fuel/technology

According to the LTA (Singaporean fleet), goods and other vehicles are primarily fuelled by diesel (Figure 4-5). A conversion to COPERT fleet classification is needed for LDVs and HDVs. All petrol-fuelled vehicles are assumed as LDVs ($\leq 3,500$ kg). Other alternative fuel/technology (except diesel) that existed in the period are considered in the LDVs category. HDVs (3,501 - $>55,000$ kg) are considered to be running on diesel.

According to LTA statistics, buses include public buses and coaches (school buses, private buses, private hire buses, and excursion buses). Because of its reliability, efficiency, and cost-effectiveness, diesel is the predominant power source for buses. As described in Figure 4-6, a small number of petrol buses were registered, considered as coaches. Simultaneously, other alternative fuel/technology vehicles are assumed for public buses. Hybrid and electric public buses were introduced on the road in the last four years. However, the share remained very low (less than 1% of the total public bus units).

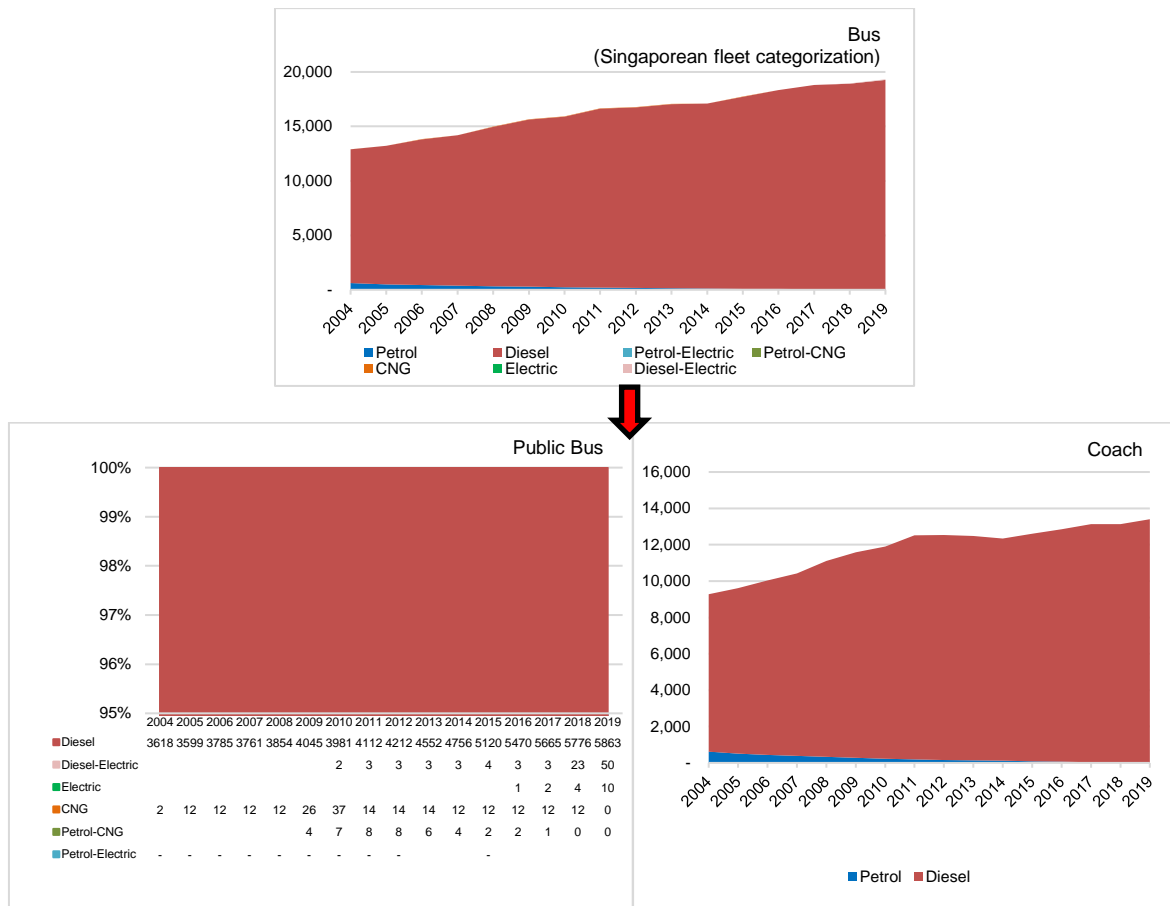

Figure 4-6: Public bus and coach population by fuel/technology

4.4.2 Vehicle fleet by engine capacity/maximum laden weight

Singapore fleet and COPERT fleet categorisation by engine capacity or maximum laden weight are not identical for most vehicle types. Therefore, an adjustment has been made for the Singapore fleet to the COPERT categorisation, as follows:

- PCs categorisation is assumed to encompass PHCs and taxis since only PCs categorisation is available. The categorisation of the PCs engine size is shown in Table 4-4.

Table 4-4: Engine capacity categorisation of PC

(1) <1,000 cc*	<0.8 l (Mini) = 80% x (1)
(2) 1,001–1,600 cc	0.8 - 1.4 l (Small) = (20% x (1)) + (80% x (2))
(3) 1,600–2,000 cc	1.4 - 2.0 l (Medium) = (20% x (2)) + (3)
(4) 2,001–3,000 cc	>2.0 l (Large SUV) = (4) + (5)
(5) 3,001 cc	

* Abbreviation: cc = centimetre cubic

- A similar adjustment was performed for MCs. In Singapore, MCs are categorized into <100 cc, 101–200 cc, 301–400 cc, 401–500 cc, 501–1,000 cc and >1,001 cc. An adjustment to COPERT’s engine size distribution is shown in
- Table 4-5.

Table 4-5: Engine capacity categorisation of MC

(1)	<100 cc	Mopeds 2S* <50 cc = 25% x (1) (*S = stroke) Mopeds 4S <50 cc = 25% x (1) Mopeds 4S >50 cc = 50% x (1)
(2)	101–200 cc	MC 4S < 250 cc = (2) + (50% x (3))
(3)	201–300 cc	
(4)	301–400 cc	MC 4S 251 cc - 750 cc = (50% x (3)) + (4) + (5) + (50% x (6))
(5)	401–500 cc	
(6)	501–1,000 cc	MC > 750 cc = (50% x (6)) + (7)
(7)	1,001 cc & above	

- In Singapore, the classification of goods and other vehicles is based on maximum laden weight, divided into ten categories, starting from <3,500 kg up to >55,000 kg. An adjustment was made for goods and other vehicles to the COPERT methodology, with three main categories: LDVs, HDVs rigid and HDVs articulated (Table 4-6). An overlap of the sub-classification can be seen for the COPERT categorisation of HDVs rigid and HDVs articulated. Since both sub-categorisations have the same range of laden weight, the Singapore fleet is distributed into HDVs rigid, and HDVs articulated based on assumptions.

Table 4-6: Maximum laden weight categorisation of LDV and HDV

Goods and Another Vehicle			
	LDV	HDV Rigid	HDV Articulated
(1) <3,500 kg	<3.5 t	-	-
(2) 35,000–7,000 kg	-	<7.5 t	-
(3) 7,001–11,000 kg	-	7.5–12 t	-
(4) 11,001–16,000 kg	-	12–14 t	-
(5) 16,001–20,000 kg	-	14–20 t	14–20 t
(6) 20,001–26,000 kg	-	20–26 t	20–28 t
(7) 26,001–32,000 kg	-	28–32 t	28–34 t
(8) 32,001–40,000 kg	-	>32 t	34–40 t
(9) 40,001–50,000 kg	-	-	40–50 t
(10) >55,000 kg	-	-	50–60 t

PCs' engine capacity has been evolving over the years (Figure 4-7). A clear trend can be observed toward owning PCs with higher engine capacity (>1,000 cc). From 2004 to 2019, a slight drop was found in the number of smaller-sized cars of 1000 cc and lower. The percentage of PCs share of 1,000 cc and below fell from 3.6% in 2001 to 1.3% in 2019. The engine size of 1,001-1,600 cc dominated the total share of the PCs category, with a steady range of about 53-58%, followed by an engine size of 1,061-2,000 cc by approximately 24-29%. Further development of MCs' engine capacity and goods vehicles' maximum laden weight is illustrated in Figure 4-8 and Figure 4-9.

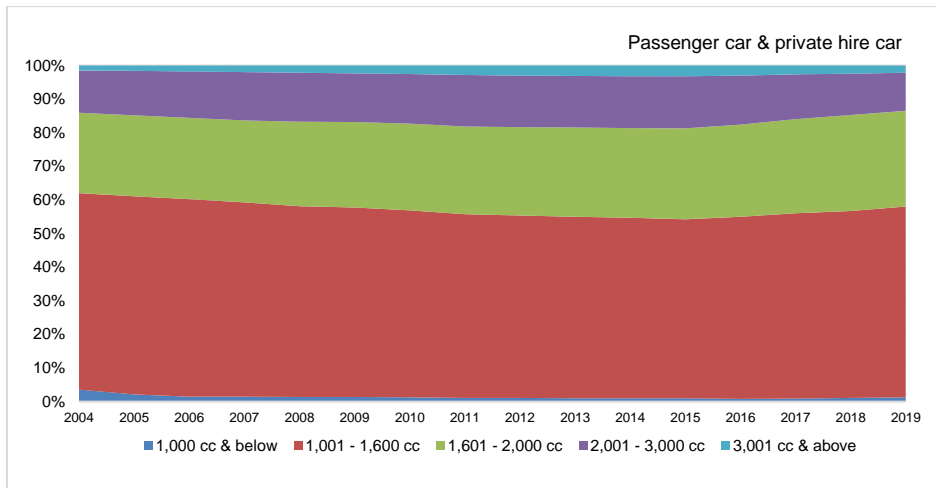

Figure 4-7: PCs share by engine size (Singapore fleet categorisation)

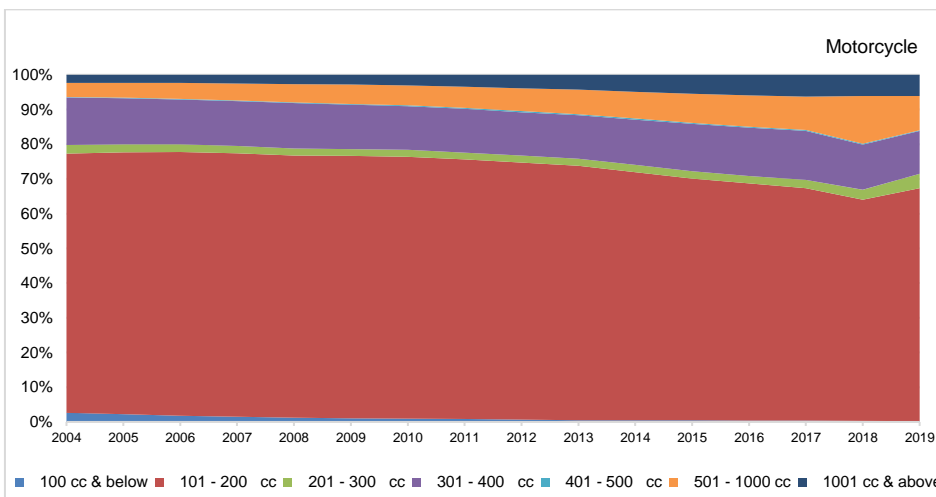

Figure 4-8: MCs share by engine size (Singapore fleet categorisation)

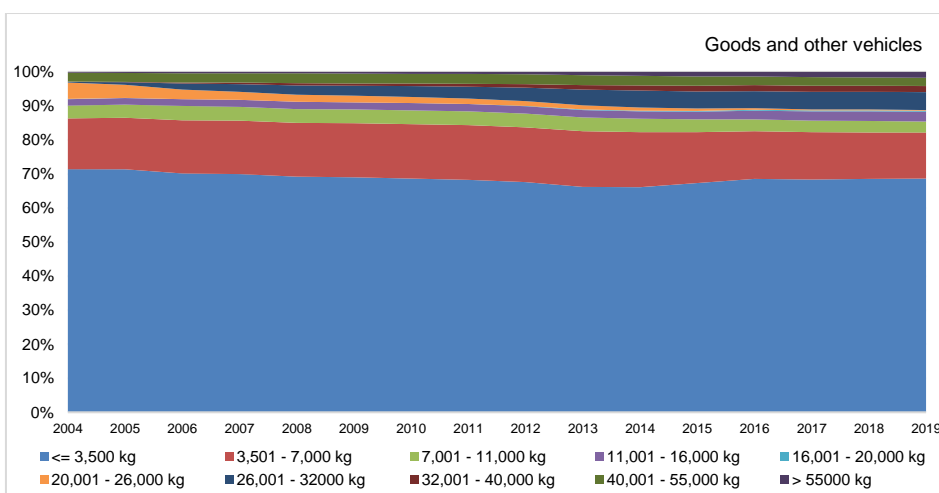

Figure 4-9: Goods and other vehicles share by maximum laden weight (Singapore fleet categorisation)

The annual road tax of registered PCs in Singapore levies progressively according to the engine capacity. A road tax surcharge is charged on top of the vehicle’s original road tax for PCs older

than ten years. The tax reflects the principle of social equity and environmental implications since higher engine capacity and old PCs tend to have higher pollution contributions. The detailed tax structure can be seen in Appendix A.

4.4.3 Vehicle fleet by age

The scrappage policy remarkably influences the vehicle survival rate and annual average vehicle age. A certificate of entitlement (COE) which indicates the right to vehicle ownership, is valid for a vehicle for an initial period of 10 years. However, vehicle owners have the option of renewing their COE for another 5 or 10 years (within the statutory lifespan) by paying the prevailing quota premium for the corresponding year or deregistering their vehicles and having them scrapped or exported. Vehicles that have reached the end of their statutory lifespan can no longer renew their COE. The lifespan of each vehicle category is different; see Table 4-7 below.

Table 4-7: The lifespan of vehicles (OneMonitoring 2021)

Vehicle Category	Statutory lifespan
Passenger car (PC)	No statutory lifespan (except it is ten years for tuition cars registered in the name of companies)
Motorcycle (MC)	No statutory lifespan, except for Vintage vehicles
Public bus (PB)	17 years
Coach (Excursion bus, private bus, private hire bus, school bus)	20 years
Goods vehicle (LDV and HDV)	20 years
Taxi	8 years

The fluctuation of PCs average age and share of PCs age are illustrated in Figure 4-10 and Figure 4-11. By 2019, the average age of PCs in Singapore was 5.47 years. The earliest average PCs age was in 2007, at 3.19 years. Since 2007, the average age increased gradually and peaked in 2014, then declined from 6.58 to 5.47 in 2018 and 2019. This trend is in contrast with other well-developed countries. For instance, the average age of cars in 2018 in Germany is 9.5, 9.0 in France, 8.0 in the UK, 8.6 in Switzerland (ACEA 2019), and in Japan 8.6 (Yamamoto and Mori 2019).

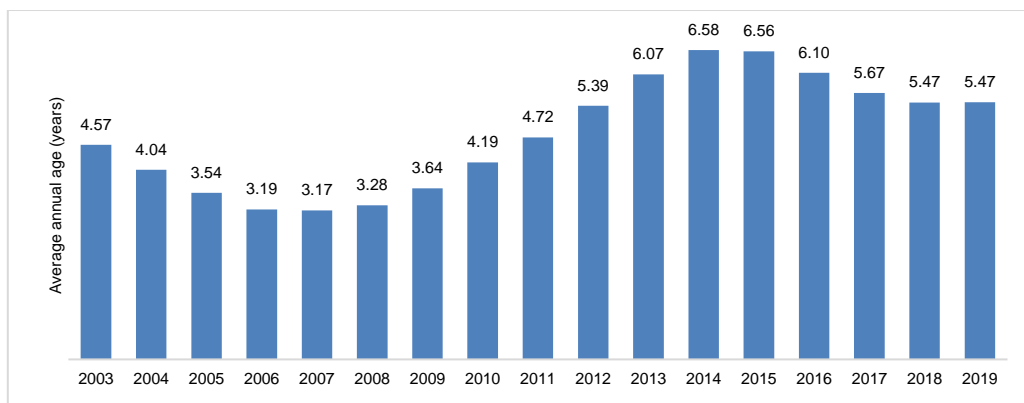

Figure 4-10: Average age of PCs between 2003-2019

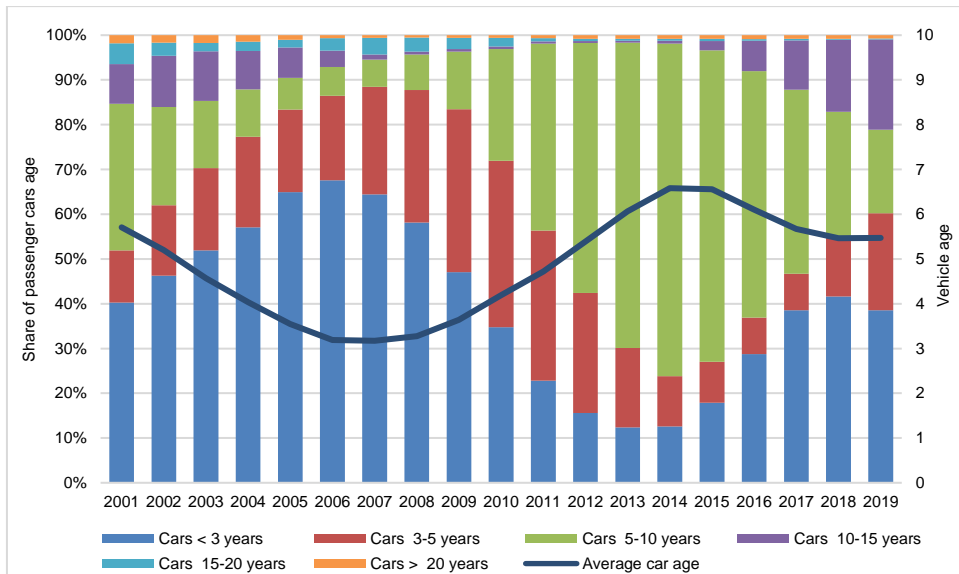

Figure 4-11: PCs age share and average vehicle age 2004-2019 (analysed from LTA data)

The PCs' average age has stagnated from 2004-2012 with a relatively young age of less than 5 years. The average age of older PCs (> 5 years) has increased from 2012 to 2015. Later, the vehicle age went down, and in the last two years, the proportion of PCs below the age of five has been growing at the rate of 60% (Figure 4-11). More younger PCs on the road is a leisure trend. However, the ageing car population is a result of numerous factors. Some of the most significant factors are explained below.

1) Growth rate

The government regularly updated and announced vehicle growth, as informed in Section 4.3. The last update was to cut the VGR from 0.25% to 0% per annum starting in 2018. This means that new PCs should only replace the scrapped ones. If only a few cars are scrapped, only a few new PCs will also be on the road, and the result is an older average PC age.

2) COE price

COE price is a function of many factors such as supply-demand for PCs, growth rate, and citizens' purchasing power (Goletz et al. 2016). If the COE prices rise, the probability of a PC owner scrapping the car at the 10-year mark falls, and potential PC buyers tend to buy a second PC at a lower price. This results in an ageing PC population.

3) PHCs' trend

Ride-hailing companies increased the number of fleets significantly since 2014. This situation requires an additional new rented PC. However, since the most prominent players Uber and Grab merged in 2018, the condition stagnated, with fewer new PCs contributing to the road.

4) Vehicle improvement

The vehicles are built with better performance as technology progresses, which implies a longer vehicle lifespan.

5) Alternative forms of transport and improvement of the public transport system

There is growing attention to alternative transport such as electric car sharing, bike sharing, and personal mobile devices (PMDs). Besides, extending more mass rapid transport (MRT) lines and new bus routes are part of public transport improvement impacting travel choices.

These factors may have a substantial effect on car demand in recent and upcoming years.

Figure 4-12, Figure 4-13, and Figure 4-14 describe the vehicle age and age distribution for motorcycles, LDVs-HDVs and buses (public buses and coaches). Unfortunately, statistical taxi data is not available.

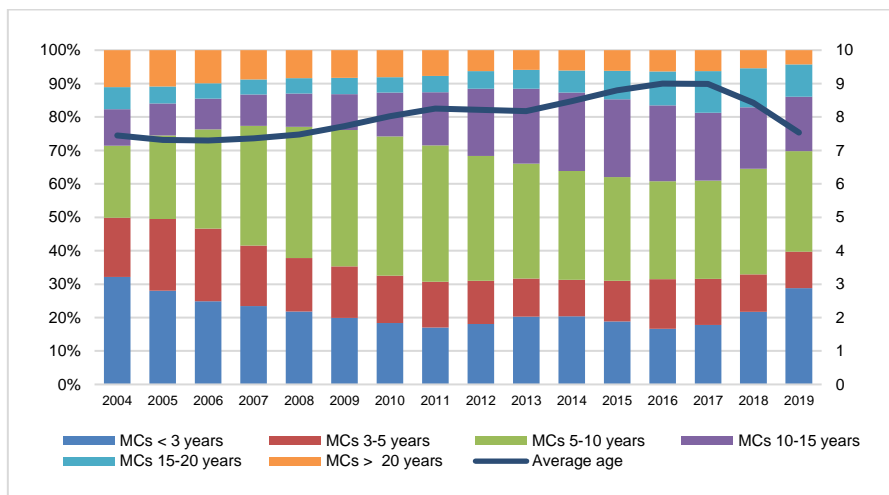

Figure 4-12: MCs age share and average vehicle age 2004-2019 (analysed from LTA data)

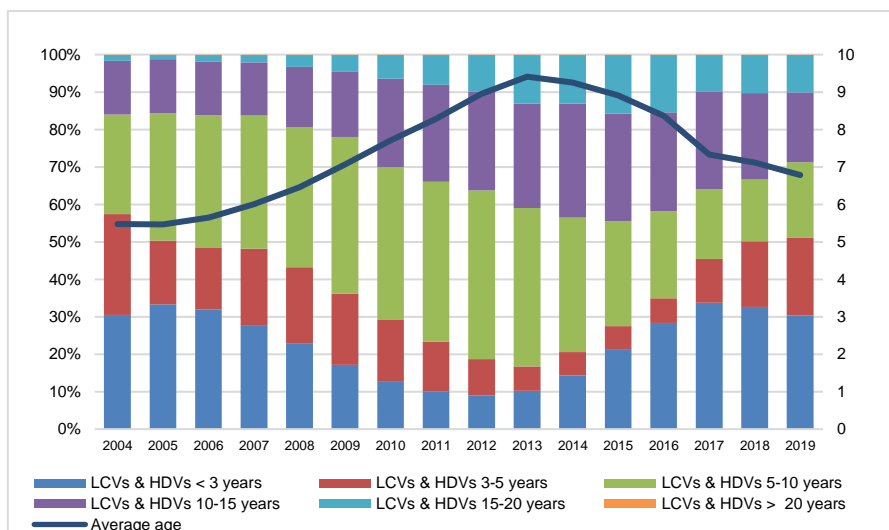

Figure 4-13: LCVs & LDVs age share and average vehicle age 2004-2019 (analysed from LTA data)

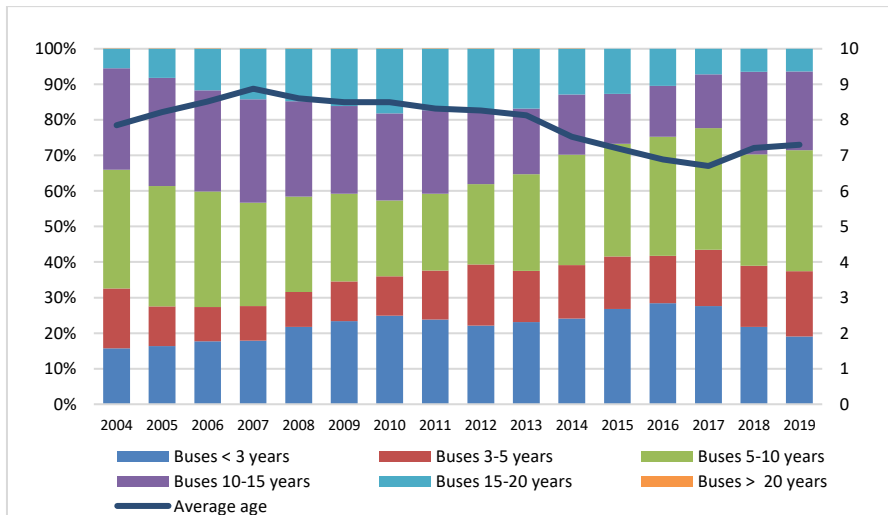

Figure 4-14: Buses age share and average vehicle age 2004-2019 (analysed from LTA data)

4.4.4 Vehicle fleet by Euro emission standards

Like European countries, Singapore follows the Euro standard band to tighten vehicle emission standards for better air quality. Unfortunately, vehicle classification data based on emission control technology is not yet substantiated in the annual statistics. Therefore, it is necessary to determine an appropriate assumption of the emission standard classification. This simulation is based on the assorted information of newly registered vehicles, vehicle age, phasing-out rate and announced dates and implementation of the various emission standards, which the NEA of Singapore pledges on behalf of the government.

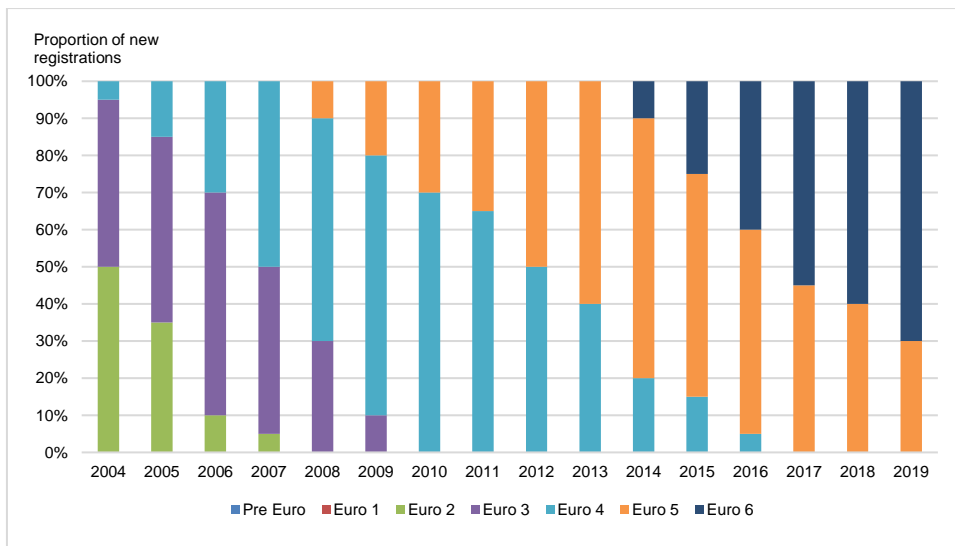

Figure 4-15: Penetration of emission concepts in petrol PC

An example of the emission concept in petrol PCs is shown in Figure 4-15, whereas the transition of emission standards for PC-petrol and PC-diesel are illustrated in Figure 4-16. PCs mainly use gasoline and diesel. The figure below shows the development of fleet composition by year in the period 2004-2019. Each colour represents the transition of Euro emission standards of PCs with respective fuel. For instance, the black rectangle indicates the status of PCs as of 2015. The coloured sections inside the rectangle reflect the vehicle stock composition by emission category in 2015.

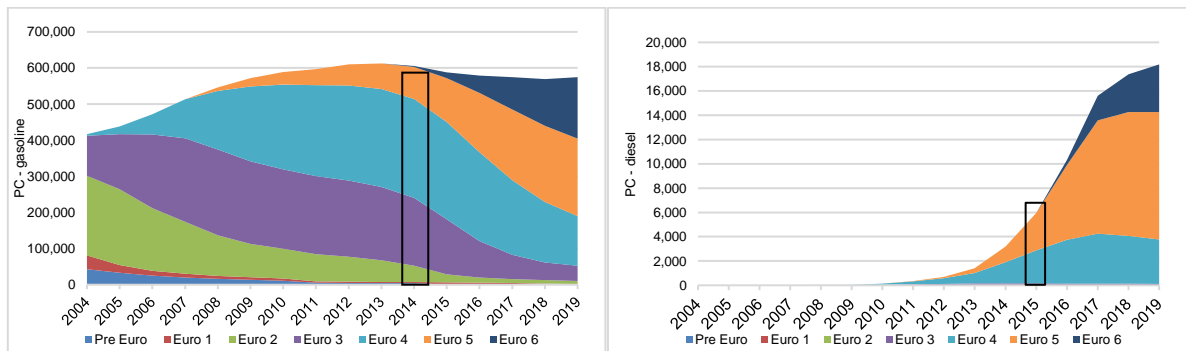

Figure 4-16: Emission standards development for PCs-gasoline and PCs-diesel, 2004-2019

The graphs above explain a sample of emission standards vehicle distribution for the specific vehicle type. This information is essential because each vehicle type represents a specific EFs, which is simulated individually. The graphs for other vehicle types are illustrated in Figure 4-17.

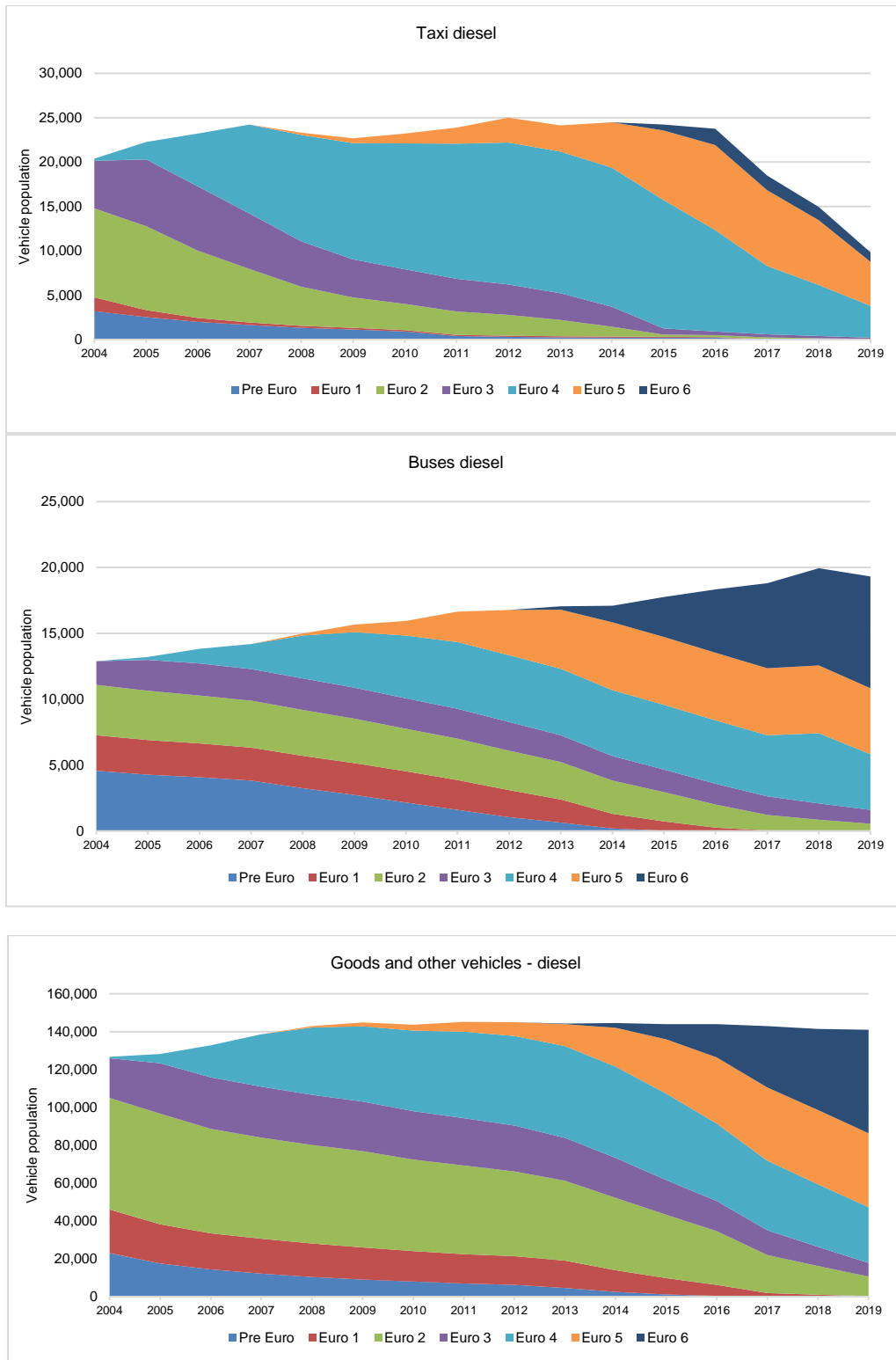

Figure 4-17: Emission standards development for diesel vehicles, 2004-2019

4.4.5 Fleet development per vehicle sub-segment/classification

Figure 4-18 shows the development of petrol-driven PCs according to vehicle size and emission standards. Each specific vehicle type represented by a specific colour is simulated with an individual EF. The yearly share of specific vehicle types can also be seen. From a regulator’s

point of view, the illustration of the specific fleet composition is an essential instrument for monitoring because it represents the PCs market due to historical and existing policies on the road.

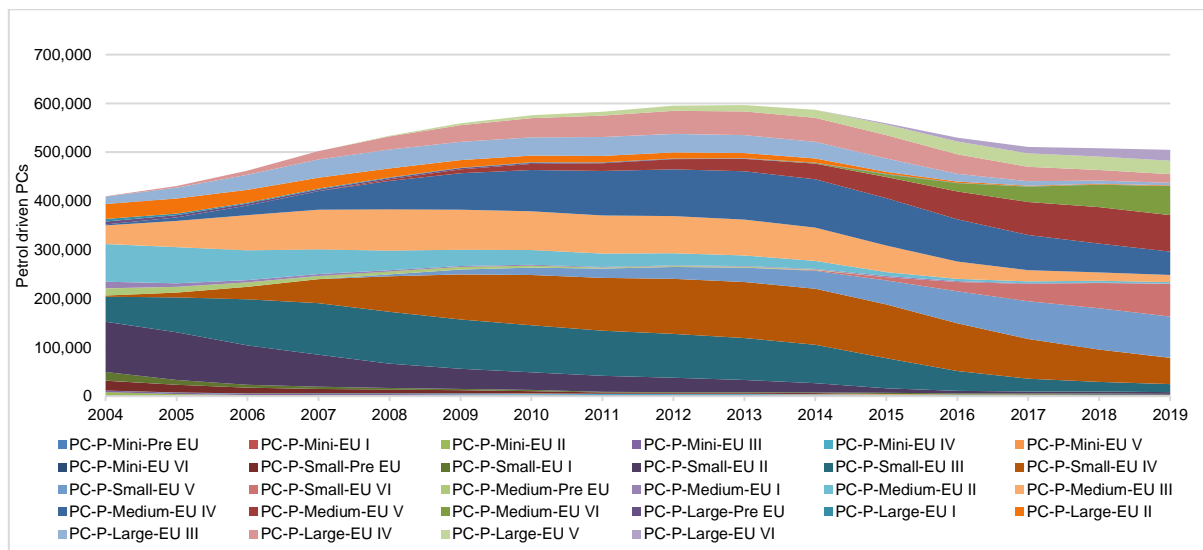

Figure 4-18: Development of PCs-petrol stock per sub-segment

4.5 Local transport characteristics

4.5.1 Vehicle ownership

Vehicle ownership (vehicles/1,000 population) concerns require a multidimensional approach that includes social, political, and economic considerations. The PCs ownership rose from 98/1,000 in 2004 and peaked at 115/1,000 in 2010, representing a 17% increase as illustrated in Figure 4-19. After 2010, motorisation slowed down due to the implementation of stricter control of vehicle growth which significantly reduced the vehicle quota. As an impact, the ownership went down gradually since 2010 to 97/1,000 population in 2019. However, if PCs and PHCs are included in car ownership analyses, the rate was estimated at 114/1,000 in 2019.

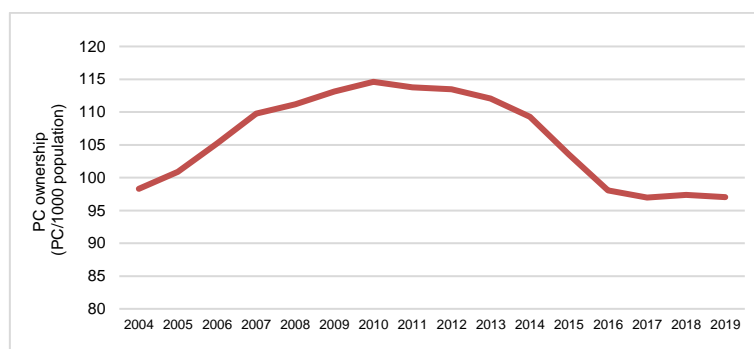

Figure 4-19: PC ownership (analysed from LTA data)

Similar ownership characteristic to Singapore is seen in Hong Kong Figure 4-20, as both countries have similar general statistic (such as small area, population, density, and GDP)

(Boey and Su 2014). These values are considered low compared to other developed countries with similar GDP per capita, as analysed by (IMF 2020). Singapore's low ownership ratio is mainly due to fiscal and regulatory measures, especially the implementation of VQS (limited vehicle quota), COE (limited licence for ten years), high vehicle ownership cost, and a highly efficient and affordable public transport system. Besides, this ratio also proves that the state has proved the importance for urban policymakers to view private car ownership as a target for regulation for successful transport sector management mainly due to the lock-in costs associated with transport sector problems (Boey and Su 2014). Furthermore, environmental benefits are obtained along with economic benefits.

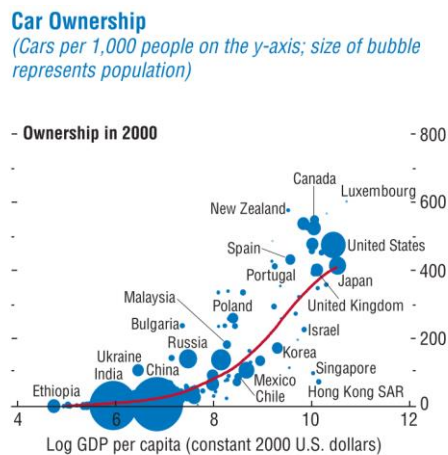

Figure 4-20: Car ownership (Boey and Su 2014)

4.5.2 Vehicle kilometre travelled (VKT)

Vehicle-use intensity is expressed in the annual vehicle kilometre travelled. The average VKT is estimated based on a distance travelled survey of in-use vehicles performed during mandatory periodic vehicle inspections. Through LTA, Singapore officially published the average VKT from 2004-2018 annually but only for limited vehicles; PCs, MCs, coaches, school buses, LDVs and HDVs. The VKT is estimated based on various indicators and other government agencies' related statical data for the rest of vehicle types, such as taxis and public buses. In general, diesel vehicles type has higher VKT than petrol vehicles in the same vehicle type category. For this case, it is assumed that VKT has the same value for each type of engine size and fuel/technology. For example, PCs-gasoline has the same value of VKT with PCs diesel or PCs CNG or PCs petrol-hybrid.

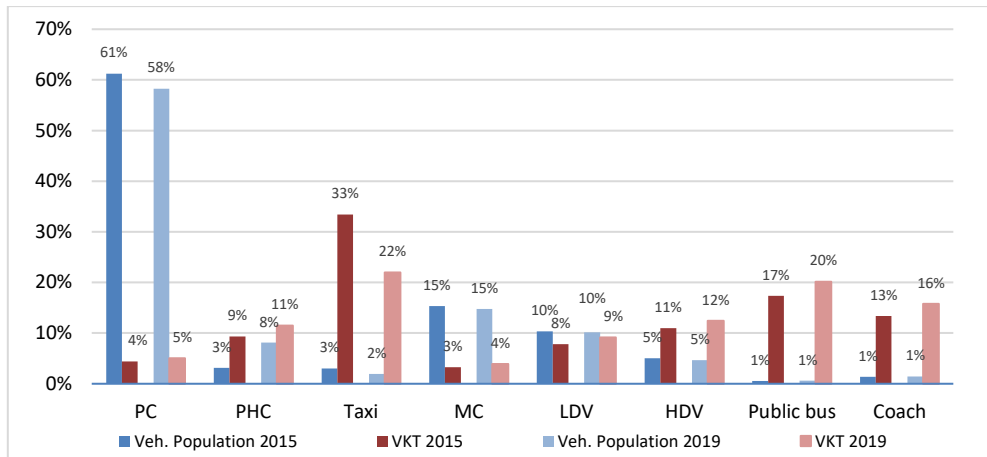

Figure 4-21: Share of vehicle population and VKT in 2015 and 2019 (analysed from LTA data)

As shown in Figure 4-21, the taxi and public bus fleet made up only 2% and 1% of the total vehicle population, but they carried one of the highest annual VKT correspondingly with approximately 22% km and 20% km in 2019 (analysed from LTA data). Therefore, these vehicles offer the highest potential for electrification (see Chapter 7 for the scenario). The VKT trends of public buses and taxis are described in Figure 4-22. A deliberate decline in VKT was found in public buses, even though the number of vehicles increased in the same period.

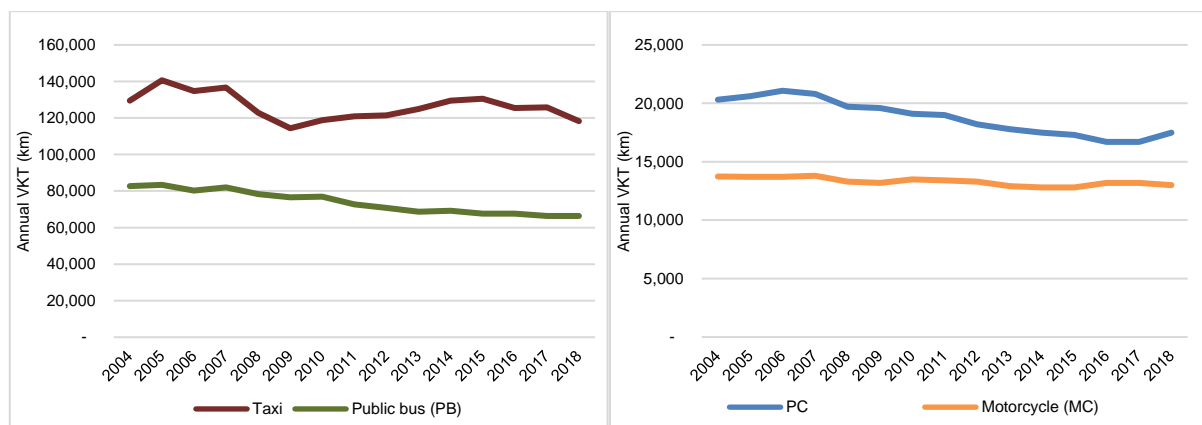

Figure 4-22: Annual average VKT of a taxi, public bus, PC and MC

Taxis are known to cover around 100,000-140,000 km per year (based on TUM CREATE internal data), much higher than regular PCs by 17,700 km. However, taxis' mileage had fallen significantly to 118,250 km in 2018 and is predicted to drop by 60% to 72,364 km in 2020 due to the PHCs' existence. PHCs tend to have higher mileage than PCs, but such figures are kept confidential by Uber and Grab. Still, it is possible to have a conservative estimate of PHCs' annual mileage. For estimation purposes, the VKT of PHCs is assumed up to twice that of PCs.

PCs motorists are driving less, with evidence in the annual average distance travelled falling consecutively for the last 12 years with 17,700 km in 2019. This is a 17% drop from a peak of

21,100 in 2006. MCs have the lowest average annual kilometre compared to other vehicle types. The usage development is considered flat, with an average distance travelled of 13,000 km in 2018 (Figure 4-23).

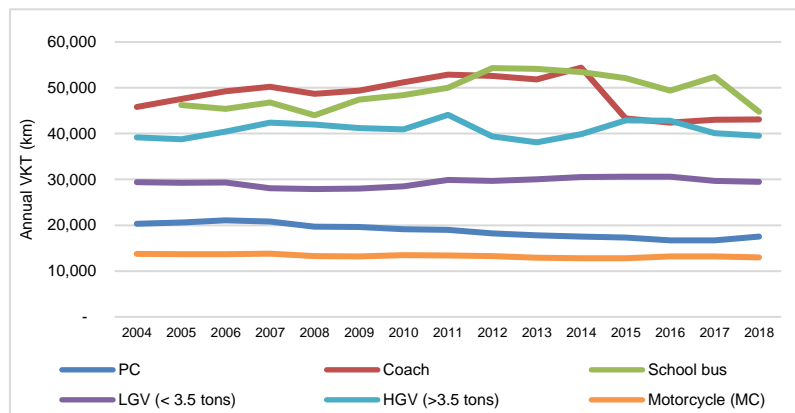

Figure 4-23: Annual average VKT of vehicles

In many cases, the total vehicles’ travel activities in a region or a country are usually characterised and compared by PCs performance characteristics, in this case, VKT. Quite contrary to famous reflection, Singapore experiences two significant trends for PCs:

- (1) Owning a PC in Singapore is an expensive affair considering one of the world’s highest car prices. This is due to the car restriction policies (e.g., COE, Open Market Value-OMV, additional registration fee (ARF), Goods and Service Tax-GST), leading to limited cars available on the road, depending on the vehicle growth rate pledged by the government.
- (2) The high average annual VKT reflects the high utilisation of PCs. For a small urban area of around 650 km² (only mainland Singapore: East-West = 50 km, North-South = 27km), an average annual VKT of 17.700 km (2018) is considered a high value. The result of the extremely high cost of owning PCs is high usage intensity and high fuel consumption. See Figure 4-24 for VKT comparison with the other developed countries.

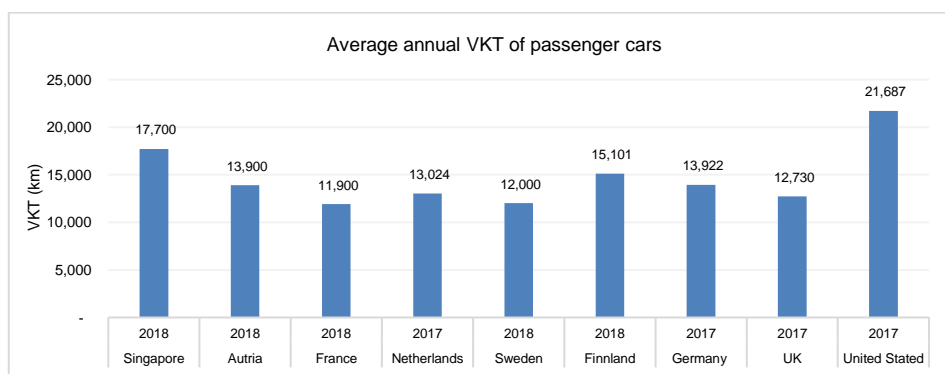

Figure 4-24: Annual VKT in developed countries (ACEA 2019; Odyssee-mure 2021; FHWA 2018)

4.5.3 Average speed

The LTA determines the speed limits. Table 4-8 explains the Singapore speed limits for different types of vehicles. The limit for all vehicle types on roads is 50km/h unless indicated in a particular segment for the specific road types. The following table details the speed limit.

Table 4-8: Speed limit on different road types (AGC 2021)

PC & MC	50km/h	50-80km/h	70-90km/h
Bus, coach & HDV	50km/h	50-60km/h	60km/h
LDV	50km/h	50-70km/h	60-70km/h

Average vehicle speed influences vehicular emissions. The average speed of vehicles is recorded based on peak hours (08.00-09.00 and 18.00-19.00) speed values provided by (LTA 2015b) and the value resulting from the Singapore driving cycle for PCs (Ho et al. 2014). Figure 4-25 explains the development of average vehicle speed in Singapore in correlation with the vehicle population. Results show that the vehicle speed remained stable over the last decade, even though the vehicle population was slowly increasing. The consistent average speed factor during peak hours resulted from implementing and expanding electronic road pricing (ERP) gantry in selected areas.

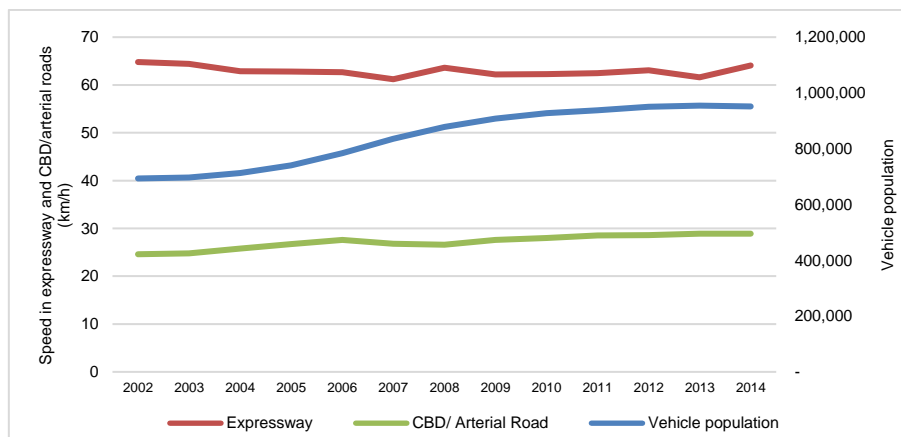

Figure 4-25: Vehicle speed vs vehicle population (adopted from (LTA 2015))

In further emissions estimation using COPERT (Chapter 5), the tool allows for driving distribution between the three road types: highway (hereafter expressway), rural and urban. Since Singapore is a city-state, the estimation considered expressway and urban types only.

Expressways play a significant role as the backbone of Singapore's road network. It is observed that the distance travelled share increased from 1990 to 2005 due to the growing proportion of expressways out of the total road network. In 2005, 44.63% of the total distance travelled by passenger cars was on expressways, although expressways represent only around 4.61% of the total road network (Fwa and Chua 2007). The distance travelled share is expected to

increase from 2019 following the previous pattern, with new expressways, such as Kallang-Paya Lebar Expressway (KPE) and Marina Coastal Expressway (MCE).

In the central business district (CBD), ERP has helped increase the average travel speed during peak hours from 24.8 km/h in 2004 to 28.9 km/h in 2014 (Data.gov.sg 2016). Average journey speeds in the CBD before 1990 were estimated at 20.1 km/h to 25.5 km/h in 2004 (Olszewski et al. 1995), whereas on expressways, the average speed during peak hours increased from 62.9 km/h in 2004 to 64.1 km/h in 2014.

Average speed values for other vehicle types are estimated based on the total average speed of PCs, V_{Total} :

$$V_{Total} = \alpha \cdot V_{Expressway} + (1 - \alpha) \cdot V_{Urban} \quad \text{Equation 4-1}$$

$$V_{Expressway} = \beta \cdot \gamma \cdot V_{Expressway} \quad \text{Equation 4-2}$$

$$V_{Urban} = \beta \cdot \delta \cdot V_{CBD/Urban} \quad \text{Equation 4-3}$$

where V_{Total} is the average speed of PCs in the total area of Singapore and α is the share of vehicle activity on expressways. $V_{Expressway}$ is the measured average speed during peak hours on expressways, and $V_{CBD/Urban}$ is the measured average speed during peak hours on the arterial roads and in the CBD area. β is the conversion factor between peak hour speed and total average speed and is assumed to be 1.05. Since the two published values $V_{Expressway}$ and $V_{CBD/Urban}$ are snapshots of specific streets, acceleration, deceleration, and idling due to the traffic conditions are not considered. To estimate the actual average vehicle speed, two correction factors γ and δ were used for highways and arterial roads, respectively. γ is estimated at 0.85; δ is assumed at 0.5.

Because of vehicle restriction strategies and policies, fleet-average vehicle speed for PCs slightly increased from 32.44 km/h in 2004 to 34.93 km/h in 2014. The average speed for LDVs, HDVs, MCs and coaches is based on these values, with the following correlation:

$$V_{Total,i} = \theta_i \cdot V_{Total} \quad \text{Equation 4-4}$$

where θ_i is the adjustment factor for MCs (1), LDVs (0.93), HDVs and coaches (both 0.9), based on secondary data given by the LTA. Public buses are measured at 18.44 km/h on average (analysed by RRT-TUM CREATE from EZ-Link public transport card 2014) and taxis were found to travel at 31.59 km/h (Moeker 2014).

4.5.4 Road vehicle transport performance

Figure 4-26 illustrates the development of Singapore vehicle transport performance. The figure demonstrates the dominance of PCs due to the highest share of PCs and their utilisation. One of the significant highlights in the last five years is the increasing number of PHCs on the road,

and at the same time, a decreasing vehicle travel activity in taxis and PCs. In other words, there was a significant shift from utilising private motorized transport (PCs) and exceptional public transport service (taxis) to public service vehicles (PHCs).

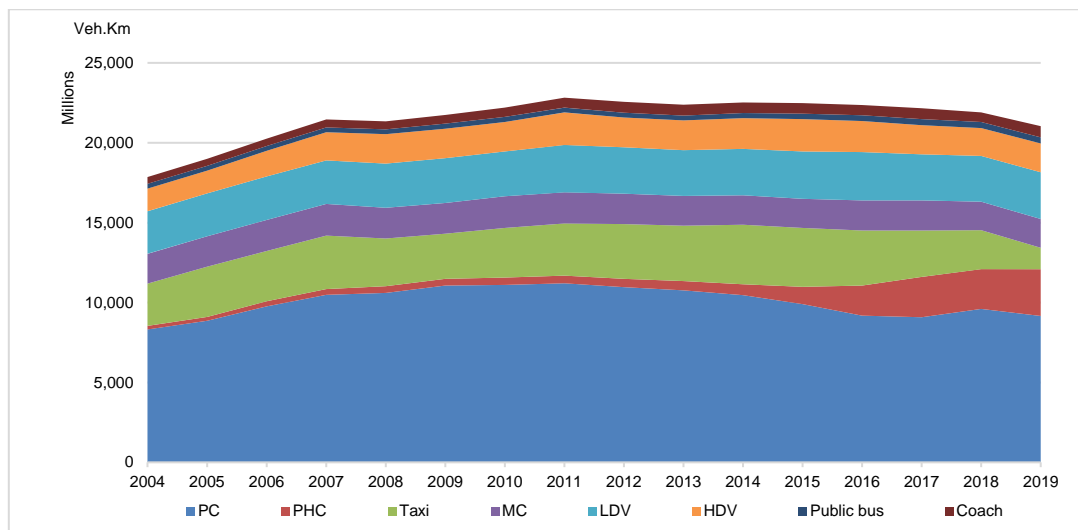

Figure 4-26: Development of fleet mileage proportion in the period of 2004-2019

4.6 Summary

This chapter determines the Singapore road-vehicle fleet and traffic-related data, mainly from 2004-2019. Some critical assumptions were taken and discussed to establish an appropriate fleet model that fits the desired average speed emissions model (Chapter 5). This chapter also discusses data availability and local observations that show the fleet's sensitivity to the local context.

According to the data sources review, the existing vehicle fleet and traffic-related data for the most relevant emissions inventory variables are assessed to be of moderate to good quality. More detailed traffic data may be available. However, these data are scattered instead of sharing through the central data institution portal.

Currently, the fleet model's quality is entirely satisfactory for the preferred emissions model, COPERT. However, there is still some room for improvement.

- The Singapore's total fleet grew by 33% over the last fifteen years, with PCs on the road leading the rose from 409,648 in 2004 to 553,455 in 2019;
- The rapid development of PHCs was one of the highlights in the period from 2014 about 18,847 vehicles to 77,141 vehicles in 2019;
- The average age of PC was 5.47 years old in 2019. Resulting of numerous policies, this age of PC is considered young and efficient.
- Diesel-powered vehicles are dominant on Singapore's roads.

Table 4-9 summarises the key trends regarding vehicle classification and transport activities. These trends are the critical elements for fleet projection, emissions projection and further transport and traffic-related policies. There is a trend of moving on towards cleaner vehicles, EVs, mainly for taxis, PHCs, PCs, and public buses. The same trend for the same vehicle category is also valid for fleet age, with a slow increase in vehicle age. For VKT, a steady movement was found in MCs, LDVs, HDVs and public buses. A clear declining VKT was identified in taxis as part of the mobility disruption phase due to the existence of newcomer PHCs in recent years. The average speed remains constant in Singapore, primarily due to the ERP policies and vehicle growth restrictions.

Table 4-9: Summary of Singapore fleet and its activities

Fleet development	Average vehicles development; annual average 2 % ; average growth 2004-2019 = (9%)							
	2.1%	18.4%	-0.4%	2.5%	3.3%	0.5%	1.4%	0.2%
Fleet technology	A decline in petrol. A slow increase in EV.	A decline in petrol. A slow increase in EV.	A decline in diesel. Increase in EV.	-	More Hybrid buses.	-	-	Still diesel, meagre increase in EV.
Fleet engine	Small (1.0 -1.6l)	Small (1.0 -1.6l)	Small (1.0 -1.6l)	-	-	Stable	3.5 -7.0 ton	100-200 cc
Fleet age	Slowly increase	Slowly increase	Slowly increase	Slowly increase	Slowly increase	Slowly decline	Slowly decline	Decline
VKT	Steady	Increase	Decline	Slowly increase	Steady	Steady	Steady	Steady
Speed	Steady	Steady	Steady	Steady	Steady	Steady	Steady	Steady

A comparison of the quality of vehicle fleet models in Singapore and other countries cannot be performed since each model has a different intention, level of detail, data quality, implementation policies, and timeline. This tool helps the stakeholders, especially the related authorities, optimise ongoing and future policy measures for sustainable mobility. Moreover, this tool is also developed to manage the data and compute the Singaporean vehicle fleet from 2004-2019 as an input of road transport emissions estimation using the average speed emissions model COPERT (Chapter 5) and as a basis for EVs fleet scenarios development (Chapter 7).

5 Application of an emissions model at a city-state scale in Singapore

This chapter focuses on the application of the selected emissions model at a city-state level in Singapore. The chapter starts with developing an emissions inventory in road transport from 2004-2019. The estimation is based on two approaches: (1) a bottom-up approach based on road traffic activities and (2) a top-down approach based on fuel consumption in the road transport sector. A comparison of the bottom-up and top-down results is presented to identify the level of agreement and consistency of the calculation using both approaches.

5.1 Introduction

Mobility in an urban area, especially in a high-density area like Singapore, is complex because of many interrelated human activities and interactions. Singapore has to determine a national inventory of GHG emissions and associated air pollutants from anthropogenic activities, such as transport, to understand the impact of its transport activities. Besides that, the Singapore government has taken a range of measures to improve the public transport system, avoid congestion on the existing road network, and introduce alternative fuels and technologies. These measures and their combinations can help to reduce both, directly and indirectly, the impact of air pollutants and GHG emissions.

5.2 Objective

The main objective of this chapter is to estimate road transport emissions for Singapore from 2004 to 2019. The estimation is based on two approaches:

(1) A bottom-up approach is based on road traffic activities. This approach covers the impact of transport activities on selected air pollutants and emissions (CO, NO_x, VOC, PM_{2.5} and CO₂) from fuel combustion sources. The outcome highlights significant emissions estimation results and identifies the relation to the Singaporean vehicle fleet and its traffic activities.

(2) A top-down approach was based on fuel sales in the road transport sector. In this case, only CO₂ is estimated.

A comparison of CO₂ emissions based on the bottom-up and top-down approaches is performed to check the consistency of different emissions estimation approaches. Besides, the results identify the road transport emission levels, understand the past emissions trends, specify the influencing parameters within the period and determine uncertainties in the emission estimation. These findings serve as an essential reference point for forecasting potential emissions reduction from EVs penetration (Chapter 7).

5.3 Emission calculation steps

5.3.1 Boundary

Since Singapore is an island state, its territorial boundary is clear and suitable for bottom-up emissions estimation. In this situation, the inhabitants' principle is used, meaning that the influence of national transport policies is directly reflected in inhabitants' transport activities, determining the territory's emissions (Duennelbeil et al. 2012). However, inhabitants' transport activities cover the territorial area of Singapore and the territorial area and small parts of transboundary road traffic to and from Malaysia. Additional traffic activities resulting from vehicles registered abroad are not included in this study. The energy sales principle is suited for the top-down approach, where the energy or fuel sales are detected only on Singapore's territory (Duennelbeil et al. 2012).

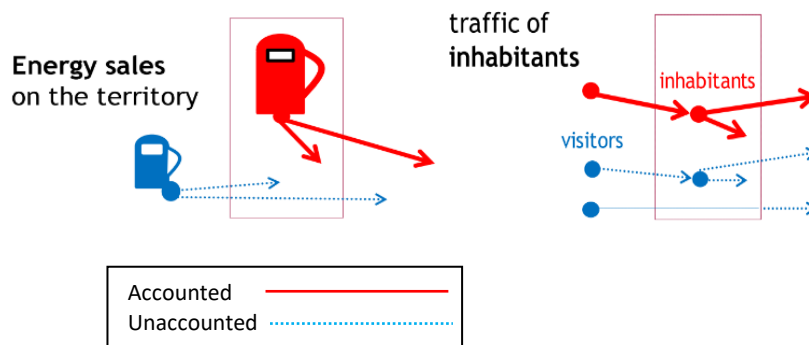

Figure 5-1: System boundaries of emission calculation for Singapore (Duennelbeil et al. 2012).

5.3.2 Methodology

As discussed in Chapter 3.4, the average speed model is an established approach in the road transport emissions inventory. The model is based on the principle that the EFs for specific pollutants and vehicle types vary over a trip according to an average speed for three driving conditions: urban, rural, and highway. Since vehicle emissions depend on the engine operation (i.e. driving situation), exhaust emissions are calculated as a function of average speed.

For this case, a bottom-up approach based on the transport activity using COPERT (version 5.4) is selected as an appropriate emissions model for Singapore. The model is regularly updated, uses the same emission standards as Singapore, is accessible and affordable and has been widely used in the last two decades for emissions quantification in most European countries and other countries. Four emission estimations are generated by the model: hot emissions, cold-start emissions, fuel evaporation emissions and non-exhaust PM emissions (i.e. tyre, brake emissions).

This model is well regarded for medium- and large-scale applications (Atjay 2005). In the last decade, this model has been used at different application scales. (Agyemang-Bonsu et al. 2010) applied it on a city scale of Kumala in Ghana, (Fameli and Assimakopoulos 2015) on a bigger-scale agglomeration area of greater Athens and (Soylu 2007) on nationwide emissions estimation in Turkey. Besides that, in other parts of the world, the COPERT model has been localised into COPERT Australia, reflecting the local EFs and fleet characteristics (Smit and Ntziachristos 2012; Smit and Ntziachristos 2013) (Section 2.6.2).

The top-down approach is typically used for a city or regional area based on total fuel sales. The approach describes total polluting activity in a geographical area of interest, such as total energy sales or fuel consumption. CO₂ emissions can be determined with only partial accuracy based on the total amount of fuel combusted and the fuels' carbon content. Only CO₂ emissions are estimated in this case (Section 2.1.1), while other air pollutants depend on combustion technology and operating conditions, which vary significantly. Using fuel sales data or fuel consumption for air pollutants over time induces reasonable uncertainties because of these factors.

CO₂ emissions are obtained from the total amount of fuel consumed by road transport multiplied by an EF. According to the IPCC, a default average CO₂ EF will be used for all motor vehicles according to the fuel type (petrol and diesel) (Waldron et al. 2006).

A detailed methodology for the bottom-up and top-down approaches is presented in Figure 5-2. In principle, road transport emissions estimation using the bottom-up and top-down approaches is carried out independently. The most reliable information from various data sources (see Table 4-1 and Section 5.3.3) is gathered and shaped for estimation in each case. Uncertain information and parameter sets are then considered with relevant knowledge and realistic assumptions. An average speed model (COPERT 5 methodology) is used with Singapore traffic activities and local characteristics for the bottom-up approach. Input parameters for emission calculations are specific vehicle stocks, emission concepts, traffic activities, EFs and related local contents (see bottom-up inputs 01 to 05 in Figure 5-2). In the top-down approach, the estimation relies on statistical fuel consumption data and the default EFs are given by the IPCC guidelines (see top-down inputs 01 to 02 in Figure 5-2) (Waldron et al. 2006). The calculated CO₂ emissions and fuel consumption of both approaches are compared to identify the results' consistency.

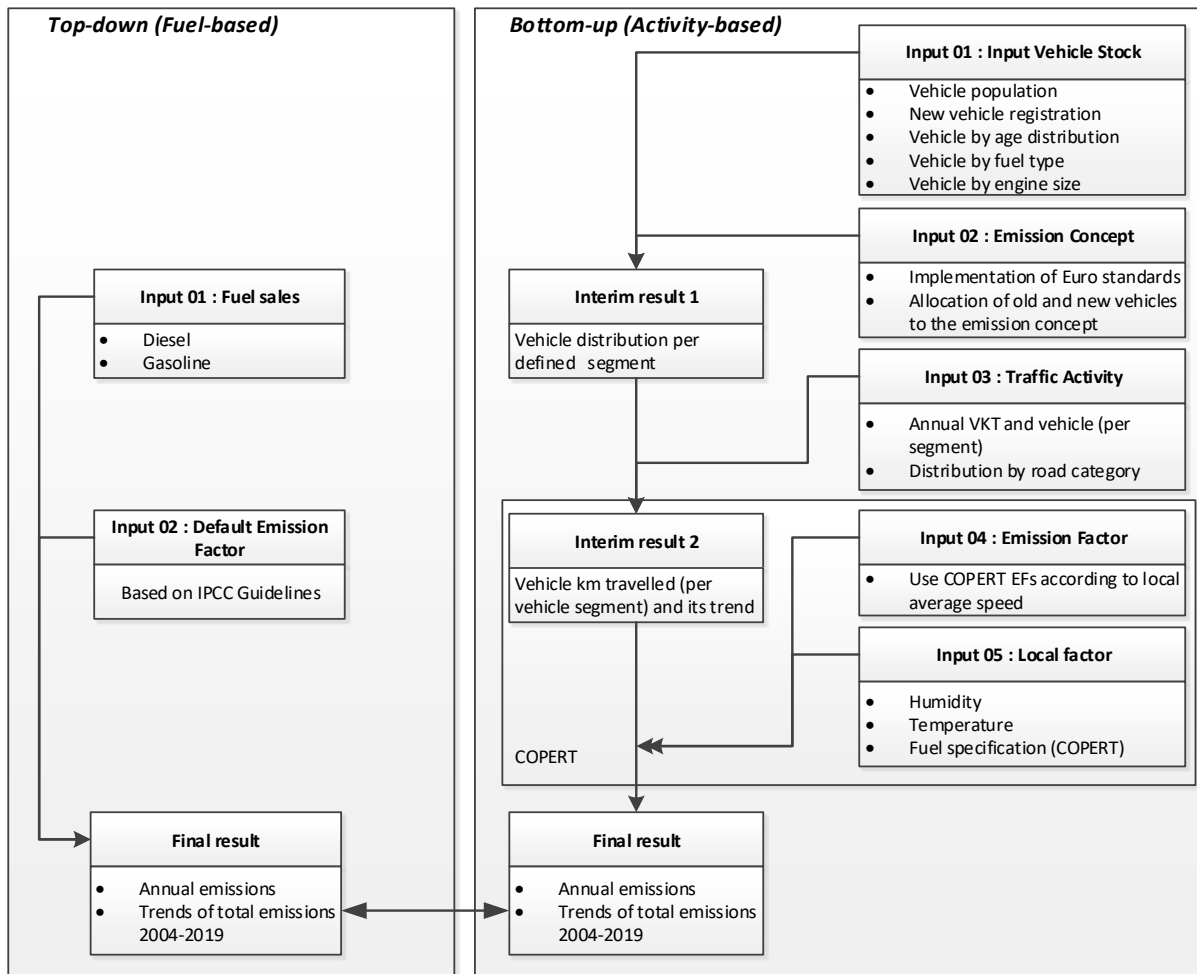

Figure 5-2: Emissions inventory model structure

5.3.3 Data collection and analysis

Bottom-up

Vehicle stock and its classification, emission concepts, and certain traffic activities have been discussed in Section 4.4 and Section 4.5. Other elements are explained below;

Traffic activity

In COPERT, the input of driving share or distribution of road category is divided into urban, rural and highway. However, due to Singapore’s densely populated urban area, the rural share is excluded from the calculation.

In a study assessed by (Fwa and Chua 2007) based on PCs travels survey in 2005, the driving share was estimated as 44.63% in expressways, 29.80% in CBD/town, and 25.56% in others. The expressway was clarified as the pillar of Singapore’s road network system while constituting only 4.61% of the total road length in 2005. Compared to the driving situation in 1990, the trend showed a significant increase in driving share in CBD/town (19,61% in 1990) and a slight

increase in driving share on the expressway (40.67% in 1990). According to the intended year of emissions estimation for all vehicle categories, an interpolation is estimated for driving share based on this information.

Emission Factor (EF)

The EFs used in this calculation were obtained from the COPERT 5 methodology. Practically, this means a specific EF is used according to the specified vehicle category (vehicle type, fuel type, engine size, emission standard) and its activity (VKT, travel activities area, speed) in Singapore's case study.

Local and regional information, such as fuel quality and meteorological conditions, are also needed as input parameters for the COPERT model. Even though EFs follow the COPERT 5 methodology, which is computed by the PHEM model laboratory measurement tests and the typical European driving cycle, local information (such as temperature and humidity) still plays a role in defining proper EFs. A correction factor is used according to the typical local condition of the input parameter.

Local Factor

As Singapore is situated near the equator line, a typical climate is tropical, with high and uniform temperatures and high humidity all year around.

Figure 5-3 illustrates the typical annual minimum and maximum temperatures from 2004-2014. The minimum and maximum temperatures ranges were 23.5°C – 27.1°C and 29.6°C – 33.5°C. For humidity, the range was identified at 73%-89%, with an average humidity of 82%. The typical tropical climate affects evaporation emissions and air conditioning use, leading to higher fuel consumption and an increase in certain air pollutants.

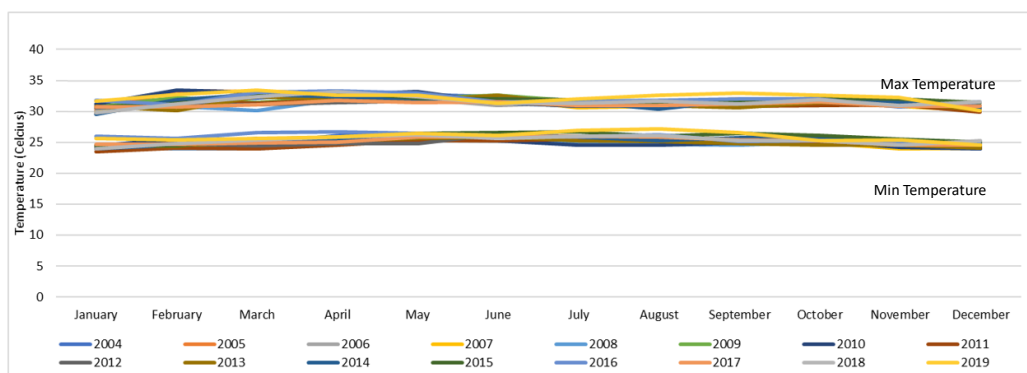

Figure 5-3: Temperature in Singapore

Data on fuel specification is not available in sufficient detail because the specifications vary from grade to grade and brand to brand due to differences in crude oil quality or refinery technology. However, the National Environment Agency (NEA) has announced further tightening of the

petrol and diesel specifications (Stratas Advisors 2018). Based on this regulation, Singapore’s fuel quality is still within the range of the typical fuel quality given in the COPERT model, confirmed by Euro standards.

Top-down

Energy use and CO₂ emissions in road transport can be analysed based on fuel consumption. Diesel and petrol fuel consumption from the road transport sector were regularly reported from 1990 to 2011 (World Bank 2015a, 2015b) (see Figure 5-4 and Table 5-1). The use of petrol and diesel increased considerably between 1990 and 2011. Diesel has dominated the use of road fuel consumption in the last three decades in Singapore with a share of about 65%.

Table 5-1: Road transport sector fuel consumption in Singapore (2004–2011)

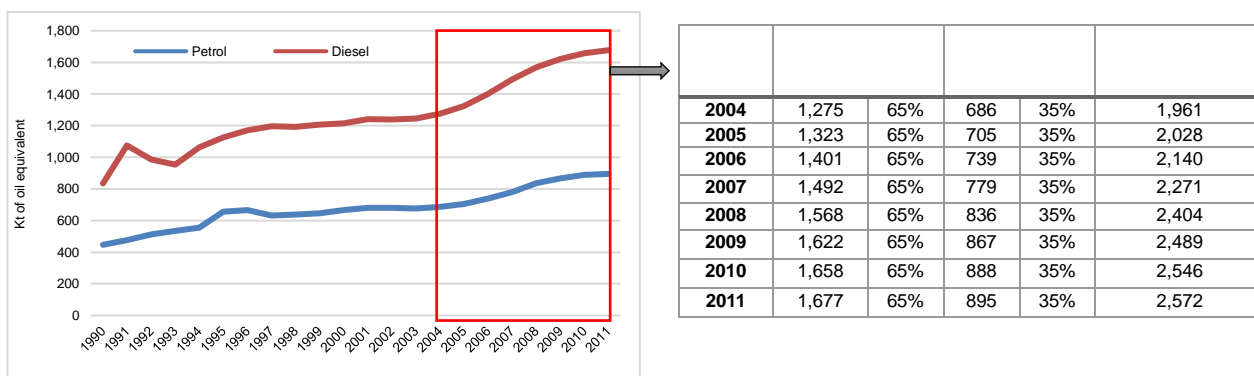

Figure 5-4: Road transport sector fuel consumption in Singapore (1990–2011) (World Bank 2015a, 2015b)

The top-down approach aligns with the CO₂ act for greenhouse gas inventory under the Kyoto Protocol and the IPCC Guidelines (IPCC 1996; Sims et al. 2014; IPCC 2006; Eggleston et al. 2000). In this case, default EFs were used according to the guideline for the specific fuel types consumed. Table 5-2 explains typical conversion factors based on the IPCC Guidelines.

Table 5-2: CO₂ conversion factor adopted from IPCC

Fuel Type	Conversion Factor	Conversion Factor	Conversion Factor
Petrol	0.74	3.14	2.34
Diesel	0.83	3.18	2.65

5.5 Results and discussion

Bottom-up results

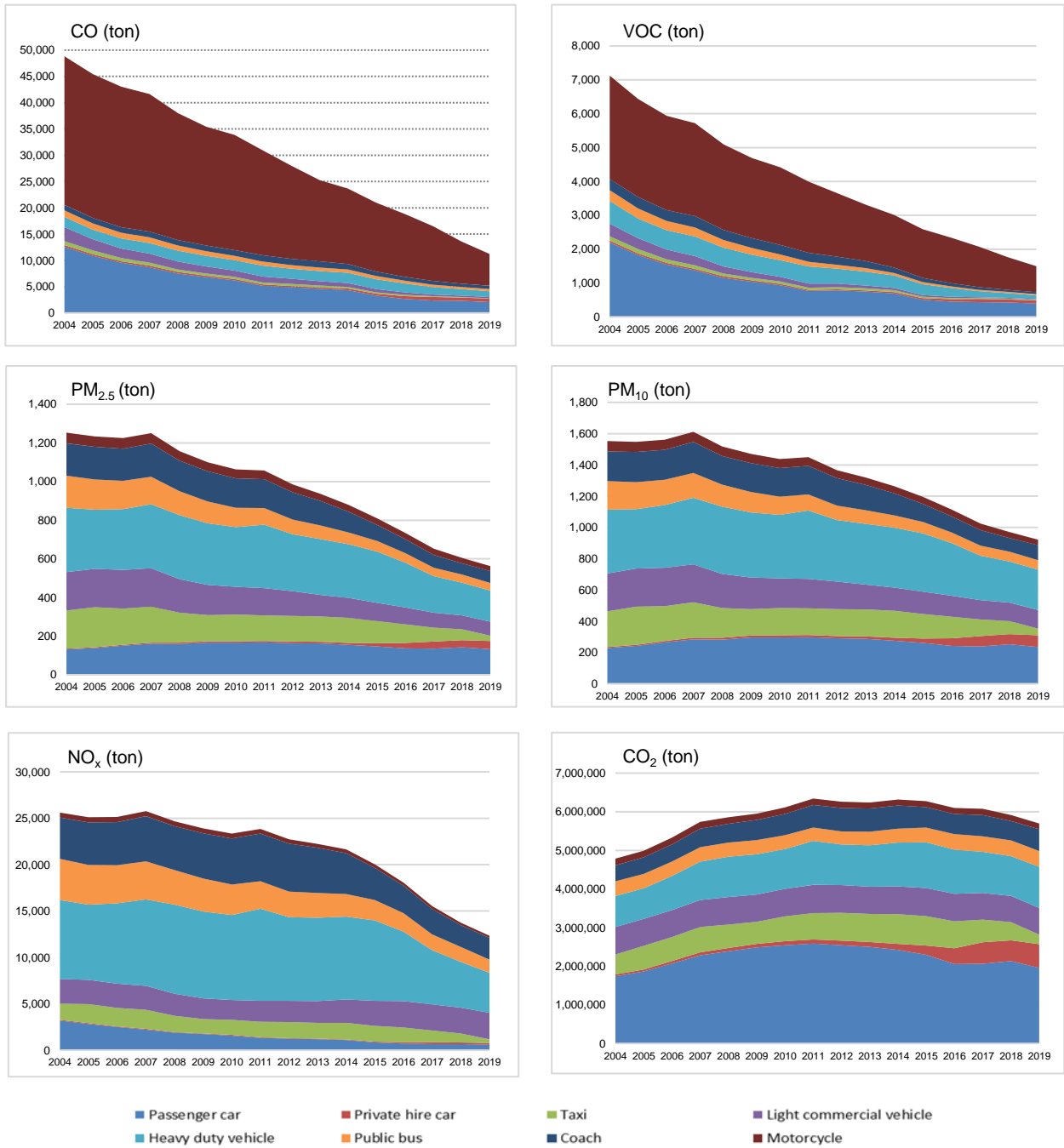

Figure 5-5: Singapore’s emissions trends by vehicle category

Figure 5-5 illustrates the estimation results for the selected emissions simulated, applying the COPERT methodology with a bottom-up approach. The graphs show the CO₂ emissions and the regulated air pollutants trends from the motor vehicles by vehicle category from 2004 to 2019. The trends for CO, VOC, NO_x, VOC, PM_{2.5} and PM₁₀ show that emissions levels declined gradually, even though the vehicle population increased during this period. These trends

occurred due to the improvement of vehicle technologies and some strategic policies in Singapore.

The total CO emissions declined drastically, by about 10% per annum, from 48.8 kt in 2004 to 11.2 kt in 2019. The reduction was about one-fourth in the last sixteen years. The significant decrease in CO is visible and mainly caused by MCs and PCs as the most significant sources. From these estimates, in 2004, MCs were found to emit 58% of the total vehicular CO emissions, although they account for just 19% of Singapore's vehicle population. A CO reduction of one-fifth was noticed sixteen years later, in 2019. The massive reduction was primarily due to the more stringent emission standards adaption (Euro I started in 2000 to Euro IV started in 2018) and improved MC's technology. A Euro I standard vehicles emit up to 11 times more CO than new Euro IV-compliant MCs; older MCs, like classic vehicles, emit even more than Euro I-compliant MCs. A similar reason for the reduction was identified in the PCs: tightening emission standards, higher turnover rate, and less VKT.

Like CO emissions, a significant declining trend was observed for VOC emissions from 2004 to 2019. VOC emissions decreased by approximately 10% on average per annum, from 7.1 kt in 2004 to 1.5 kt in 2019. As seen in Figure 5-5 (VOC graph), petrol-fueled vehicles (PC and MC) are generally dominated by VOC emissions. In the first year of the timeline (2004), MCs contributed the bulk (43%) of VOC emissions among all vehicle categories, followed by PCs (PCs and PHCs) (31%), HDVs (9%), LDVs (5%), coaches (5%), public buses (4%) and taxis (2%). The share remained almost the same for all vehicle types in 2019. The leading cause of reduction was the adoption of a better emissions standard.

Compared to other pollutants (Figure 5-5, NO_x graph), the NO_x emissions trend showed a slightly different declining trend, with a slow reduction curve in 2004-2014 (annual growth -2%) and a significant drop in 2015-2019 (annual growth -11%). About 5% of the annual average decline was identified in NO_x emissions (25.6 kt in 2004 to 12.3 kt in 2019). In 2019, HDVs (35%), LDVs (23%), coaches (19%), and public buses (11%), mostly powered by diesel, were the main contributors to NO_x emissions (89%).

As illustrated in Figure 5-5 (PM_{2.5} graph), PM_{2.5} emissions decreased moderately, from 1.3 kt in 2004 to 0.6 kt in 2019. Emissions of PM_{2.5} and PM₁₀ are closely related to diesel vehicles. PM₁₀ reduction in 2019 was one-third of 2004, dropping from 1.5 kt to 0.9 kt. HDVs, with a share of 5%, were the most significant contributors to PM₁₀ and PM_{2.5}, with a share of 28% and 29% in 2019.

CO₂ emissions increased gradually, with an annual growth of 4% from about 4.7 Mt in 2004 and peaking at 6.3 Mt in 2011. Emissions rose due to the increase of VKT and increased fuel consumption from 2004 to 2011. Between 2012 and 2015, CO₂ emissions remained stable at

around 6.2 Mt. A moderate decline was identified from 2016 to 2019, from 6.1 Mt to 5.7 Mt. A significant reduction was identified due to the combination of several policies, including the carbon emissions-based vehicle scheme (CEVS), the restriction of vehicle growth rate, and other economic instruments. The CEVS is intended to encourage vehicle buyers to buy new low-emission cars and charge or provide a rebate according to average carbon emissions per km (CO₂/km).

PCs contributed the most CO₂ emissions during the entire period. In 2019, PCs had a share of 34% of the total CO₂ emissions, followed by HDVs with 19%, LDVs with 12%, PHCs with 11%, coaches with 10%, public buses with 7%, taxis with 4% and motorcycles with 3%. Another highlight found in taxis in 2014 is that, despite accounting for only 3% of the total population, they caused 12% of total CO₂ emissions due to their highest VKT. However, this trend changed dramatically since 2015 by the growing existence of PHCs (e.g. Uber, Grab) on the road serving a similar taxi function.

With a small share of 2% of the total vehicle population, coaches and buses contributed around 10% and 7% of the total CO₂ emissions. Nevertheless, the CO₂ emissions per person-km from coaches and buses are expected to remain the lowest compared to other passenger vehicles since both coaches and buses provide a high occupancy rate in Singapore's densely urban area.

Regarding the CO₂ EFs, vehicle efficiency has increased mainly for PCs. The effectiveness of vehicles is impacting Singapore's fleet, even though the citizens tended to buy larger engine size PCs in the last decade (see Figure 4-7 for changes in car fleet composition by engine size, 2004–2019). Furthermore, due to vehicle restriction policies, in various fiscal measures (Appendix A), PCs' turnover in Singapore is substantially higher compared to other countries. As shown in Figure 4-11, the average age of cars in 2019 was less than 5.47. The younger average age of vehicles tends to have more efficient EFs due to less degradation in the emission control system. These vehicles also usually have newer vehicle technology and more stringent emission standards, which are likely more efficient and less polluting.

Top-down results

According to the fuel consumption principle, CO₂ emissions were estimated for the top-down approach, using fuel consumption data (published by the World Bank) from road transport for a consistent time series from 2004 to 2011 (see Figure 5-6). However, no natural gas consumption data are available, and national fuel consumption data are only available for a limited period of 2004 – 2011, while 2012-2019 data are missing.

Figure 5-6 describes the estimated CO₂ emissions increased considerably from 5,951 kt in 2004 to 7,806 kt in 2011, with an average annual growth rate of 4%. However, the share of diesel remained the same from 2004 to 2011, at about 67%. In addition, the vehicle fleet data support the argument that the increase in CO₂ emissions primarily comes from diesel. For instance, taxis, public buses, coaches, LDVs, and HDVs, with high annual VKT, mostly consumed diesel, while other vehicles with less annual VKT used petrol.

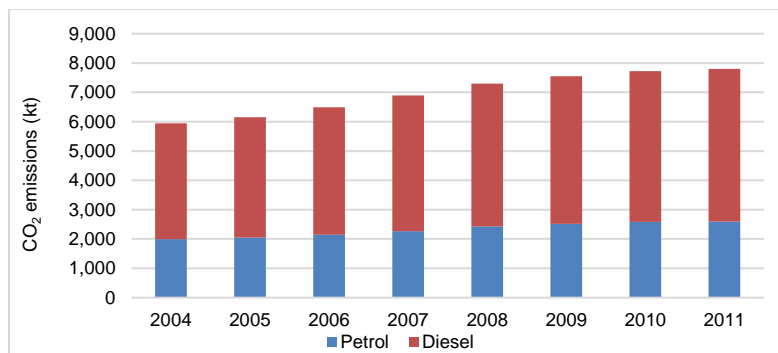

Figure 5-6: Singapore's road transport CO₂ emissions based on a top-down approach (2004–2011)

Comparison of bottom-up and top-down results

The comparison of CO₂ emissions for 2004-2011 using top-down and bottom-up estimation is shown in Table 5-3, Table 5-4 and Figure 5-7. The quantitative analysis revealed a remarkable difference over the period, as each approach is subject to different data sources, data quality and methods. CO₂ emissions calculated on the fuel sales principle are higher than estimated based on inhabitants' traffic activity using COPERT. An average annual absolute difference value of 20% corresponds to the calculated CO₂ emission from the World Bank's fuel consumption data. However, both approaches are consistent in showing the increasing CO₂ emission trend with an annual average growth of 4%.

Table 5-3: Top-down vs bottom-up CO₂ emissions estimation

Year	Top-down (kt)	Bottom-up (kt)	Absolute Difference (%)
2004	5,950.52	4,787.05	20%
2005	6,154.72	4,994.36	19%
2006	6,495.62	5,327.24	18%
2007	6,894.31	5,741.31	17%
2008	7,295.78	5,859.49	20%
2009	7,553.45	5,953.30	22%
2010	7,726.20	6,112.16	21%
2011	7,805.52	6,341.55	19%
Average or (annual average growth)	- (4%)	- (4%)	20%

Further review of Singapore's past studies is used to validate the bottom-up CO₂ emissions estimation, as listed in Table 5-4. The result shows a slight value in the NEA estimation with an absolute difference of 6-7%, whereas (Frost & Sullivan 2011) indicate a higher difference with about 16%. Unfortunately, the detailed methodology of CO₂ estimation was not identified in

either of the sources. However, the comparison validates that the bottom-up approach results are within acceptable result.

Table 5-4: Bottom-up vs another CO₂ emissions estimation

2010	6,112.16	7,100.00	(Frost & Sullivan 2011)	16%
2011	6,341.55	-	-	-
2012	6,261.78	6,706.19	(NEA 2016)	7%
2013	6,237.38	-	-	-
2014	6,313.69	6,662.98	(NEA 2018)	6%
2015	6,277.87	-	-	-
2016	6,100.64	-	-	-
2017	6,075.87	-	-	-
2018	5,913.69	-	-	-
2019	5,694.47	-	-	-

Additional estimated CO₂ emissions in 2010 per vehicle category is estimated by (Frost & Sullivan 2011) with the following assumptions: (1) fuel efficiency (a diesel engine is 20% more efficient than a petrol engine, a petrol hybrid is 80% more efficient than a petrol engine, petrol CNG is 25% more efficient than gasoline engine); (2) fuel CO₂ emission conversion factor (2.3 kg/l for gasoline and 2.6 kg/l for diesel engines).

A comparison of CO₂ emissions in 2010 per vehicle type is illustrated in Figure 5-7. The main difference estimation was found in PCs, taxis and LCVs categories; the estimated emissions completed by (Frost & Sullivan 2011) were slightly higher than those estimated by COPERT methodology. However, the total share of each vehicle category did not differ significantly in both estimated CO₂ estimations.

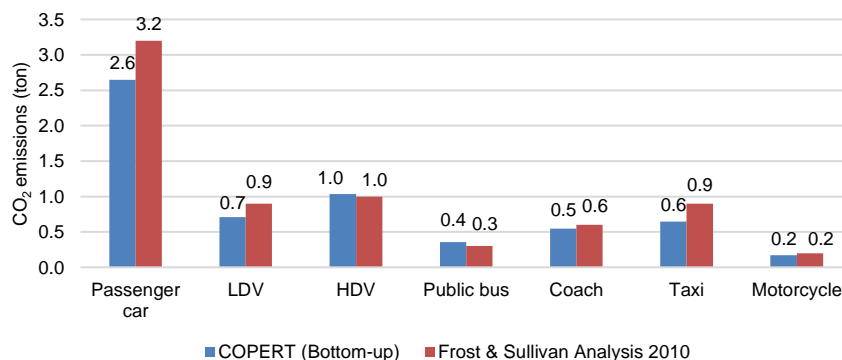

Figure 5-7: Studies comparison of road transport CO₂ emissions by vehicle type in 2010

5.6 Limitations

There are certain limitations related to the standard data and methodology adopted in this study. The bottom-up calculation does not cover tax-exempted vehicles for goods and other vehicles, including those for all off-road use. The vehicles in this category also consume fuel and cause emissions, although their number on the road is small.

Another limitation is found in vehicle fleet configuration. The detailed level of vehicle segment classification is sufficient, except that the emissions standards category is missing. Information about the correlation between the fleet's sub-segments is needed.

Several assumptions are taken to estimate the annual VKT, i.e. the same annual VKT is used for the general vehicle type (e.g., PC, MC, LDV, public bus), without any VKT's influence on vehicle age, fuel type and engine size. Further reliable data is needed to represent the real VKT to determine the dropping functions of annual mileage with vehicle age. Fuel quality was assumed to be the same for all years simulated. Therefore, certain aspects of this study may need revision in the future, such as the detailed fleet model (a coherent vehicle breakdown) with vehicle activities, driving cycle and EFs, should the local Singapore conditions become available and accessible.

COPERT, as the average speed model approach, has some drawbacks, especially in a typical urban area like Singapore, where a range of traffic situations (for example, free flow, steady flow, and unsteady flow) occur periodically. Therefore, a better methodology, such as applying a traffic situation approach (e.g. HEBFA emissions model), could be further investigated once the detailed data requirement is accessible.

In analysing the emissions using COPERT, it was not possible to add a user-defined vehicle category since the configuration reflects most vehicle stocks in European countries. In the example of Singapore, PCs, PHCs and taxis are under the same vehicle category and vehicle sub-segments but have different vehicle activities (e.g., VKT). However, the PHCs and taxis must be simulated independently since they have different VKT than PCs. Besides, the current version of COPERT 5.4 has limited EFs for alternative new technology vehicles such as BEV.

In addition, there are uncertainties identified in EFs, as used in COPERT. Such EFs can vary noticeably and consequently lead to poor results as EFs depend on several local conditions such as typical driving cycle (e.g. driving style and condition), fleet composition, fuel quality, fleet age, and regular inspection and maintenance of vehicles.

In order to improve the data quality using the top-down approach, different data sources should be cross-checked. For instance, fuel sales statistics can be compared with fuel production data from refineries and import statistics. Also, the statistics on CNG consumption need to be identified and used in this approach.

Apart from the source's statistical fuel sales uncertainties, other possible estimation difference between top-down and bottom-up approaches is attributable to transport activity to and from neighbouring Malaysia, especially for logistical and regular commuter purposes. In addition, the fuel price and fuel quality have always been lower in Malaysia compared to Singapore. Besides,

the off-road vehicle activities (e.g. construction machines, vehicles for industrial use) should be included in the estimation, as they are linked closely with diesel consumption.

5.7 Conclusion

The modelled fleet and activity were applied using the average speed model COPERT to annually estimate road transport emissions (CO, NO_x, PM_{2.5}, PM₁₀, VOC and CO₂) from 2004 to 2019 in Singapore. At the same time, CO₂ emission was estimated based on fuel sales data multiplied by default EFs.

The results show that the emissions in the year 2019 and the trend of average annual growth from 2004 to 2019 was about 11.2 kt for CO (-9%), 12.3 kt for NO_x (-5%), 0.6 kt for PM_{2.5} (-5%), 0.9 kt for PM₁₀ (-3%), 1.5 kt for VOC (-10%), and 5.7 kt for CO₂ (1%). The emissions loads for all pollutants showed a decreasing trend in the period studied. A clear dramatic reduction trend was found for pollutants CO and VOC, with PCs and MCs as the ultimate primary sources. NO_x, PM₁₀ and PM_{2.5} emissions, mainly released by diesel vehicles, slowly decreased due to the increase in the vehicle population using diesel and VKT. A different trend was found in CO₂ emissions with an annual growth of 4% from 2004-2011, a stable trend from 2012-2016, and a significant decrease from 2017-2019.

From a global perspective, the progressively tighter emission limits (e.g., Euro emission standards) have pushed the automobile industries to improve new vehicle technologies, and at the same time, have accordingly contributed to a significant reduction in vehicle emissions worldwide. Although the Euro emission regulations are not updated regularly, motor vehicle emissions in Singapore are likely to continue to decline significantly. This is mainly a result of the series of transportation policies such as vehicle growth control, VQS, COE (which impacted the higher turnover rate of vehicles) and the combination of other fiscal measures (e.g., vehicle taxes).

The CO₂ emissions estimation from the activity data (bottom-up approach) is compared with the CO₂ emissions from the fuel sales data (top-down approach) to address the reliability of the results. There is less agreement, with a difference of 20%. Top-down and bottom-up approaches could have a narrower difference when other users of fuels are considered (e.g., vehicles from the neighbouring country Malaysia, off-road and non-road sectors should also be included).

This emission estimation consists of limitations and provides only historical emissions estimation and its past trend, but the result and methodology are a good foundation for analysing future developments and scenarios to support environmentally-friendly mobility. Furthermore, these results stimulate the stakeholders to evaluate sustainable development

benefits and continue implementing sustainable transport policies and mitigation actions (e.g. ERP and VQS).

One of the crucial points in the emissions inventory is the reliability of data. Therefore, the data must be updated and evaluated regularly. EFs should also be reviewed as they contain uncertainties and leave room for validation using real-world measurement on the road (Chapter 6).

An option to further decrease the air pollutants and CO₂ emissions could be introduced by providing more significant incentives and policy supports for the penetration of new vehicle technology, such as EVs in Chapter 7), primarily since electricity is mainly produced from natural gas. Furthermore, emissions reduction from different scenarios provides information supporting transport policies' effectiveness and environmental co-benefits to achieve the government's sustainability goals.

6 Determination of Average Emission Factor based on the Tunnel and Open Road Measurements

Road transport emissions estimation in Singapore's context can be estimated using an overseas emissions model, as explained in Chapter 4. However, uncertainties arise from specific factors, such as vehicle-fleet characteristics, fuel used, emission factor (EF), and traffic characteristics (Section 2.2). One of the significant uncertainties of emissions estimation is EFs (in g/veh-km), i.e. emitted mass (g) per vehicle travel distance (km) and vehicle. An accurate EF is essential to recognise the vehicle's emissions contribution to the air. There are various ways to estimate fleet average or aggregated EFs from mobile sources (traffic), including remote sensing, mobile laboratory, open road, and tunnel study (Section 2.4).

This chapter aims to determine the real-world vehicle EFs in actual conditions in Singapore. Besides, the determined aggregated EFs are used to validate the EFs estimated by COPERT emissions model. In this case, the real-world measurements are conducted at the link level, in this case, the selected urban tunnel and open roads. According to the researcher's knowledge, this study is the first study that reports selected pollutants EFs derived from a tunnel study in the country and South-East Asia.

The following sections cover the Kallang-Paya Lebar Expressway (KPE) tunnel measurements and the selected open roads. Characteristics, methodology, field experiments, results, discussion and conclusions are covered. A comparison of EFs results between KPE and other tunnel experiments in overseas countries is also presented.

Open road measurements are conducted within a limited timeframe as an extension of the tunnel analysis to determine EFs under different traffic conditions. Lessons learned are gathered and summarised while considering data reliability and results in constraints.

6.1 Tunnel measurement

6.1.1 Tunnel and its characteristics

From an environmental perspective, a road tunnel is a space where traffic emissions are derived from a link and section of the road. The air pollutants and emissions are typically concentrated at one or a few points through the ventilation system before the air is released into the atmosphere. Air pollutants emitted in the tunnel air depend on several factors: (1) the traffic flow (density) inside the tunnel and (2) the intensity and characteristics of vehicle emissions (Meng et al. 2011).

Road users experience the air quality differently, especially motorcyclists since this user has more direct exposure inside the tunnel than other road users. In-tunnel air quality monitoring, such as CO and NO_x, is commonly measured and monitored along with the visibility to ensure

that the air quality is acceptable to the motorist (tunnel users). In a given time frame, a certain mass of pollutants inside the tunnel can be influenced by several factors such as traffic flow, speed while the vehicle is moving, the mix of vehicle types, the EF per vehicle, and the fuel used. However, the influencing factors can also be affected by meteorological conditions and vehicle mix related to activities near the tunnel area.

Also, in-tunnel measurement has been used for different purposes in the last few decades. Some of the purposes are to test the effectiveness of ventilation design and control the effectiveness of air pollutants regulation (Staehelin et al. 1994), to determine the real-world fleet mix EF and validate the EF with other models (Hausberger et al. 2003b). Tunnel studies have proven to be a robust and economically friendly approach to obtain aggregated real-world EFs compared to other real-world measurement methods (as confirmed later in Table 6-6)

6.1.1.1 Tunnel studies for EFs development

Different approaches have been established to determine the EFs. Chassis dynamometer or testbeds measurements in the laboratories using the acknowledged driving cycle can represent the actual situation. However, there is limited information about EF or EFs models' validity in a real-world situation on the road. In this case, a road tunnel study can also be considered an extensive laboratory test due to its particular circumstances while at the same time representing the real-world situation. The validation will provide corrected information on the EFs model. Likewise other alternative studies, tunnel studies have some advantages and disadvantages, as summarised in Table 6-1.

Table 6-1: Advantages and disadvantages of traffic tunnel studies (Corsmeier et al. 2005)

Traffic	<ul style="list-style-type: none"> ▪ Able to capture on-road vehicle fleet and represent the different real-world operation ▪ Under controlled conditions: <ul style="list-style-type: none"> ○ Typically, the smooth uncongested traffic situation ○ High speed ○ Classical flow conserving bottlenecks (entrances and exits) 	<ul style="list-style-type: none"> ▪ May not reflect the whole urban situation (limited range of operating conditions) ▪ Unrecognised vehicle loading ▪ The assumption of the proportion of cold-start vehicles is zero
Meteorological	<ul style="list-style-type: none"> ▪ Wind directions are defined in a one-way tunnel 	<ul style="list-style-type: none"> ▪ The temperature might be different as ambient temperature depends on traffic flow
Air pollutants	<ul style="list-style-type: none"> ▪ The source of air pollutants is clearly the traffic sector ▪ The average absolute level of pollutants can be measured 	<ul style="list-style-type: none"> ▪ May include bias in uphill and downhill gradients ▪ For PM, an additional problem originates from the contribution of both exhaust and non-exhaust sources to total concentrations ▪ Rely on direct measurement rather than exhaust measurement
Operational	<ul style="list-style-type: none"> ▪ Well-defined volumes of air 	<ul style="list-style-type: none"> ▪ Difficult to get a permit for the installation of air quality equipment ▪ Time-consuming and costly
Other	<ul style="list-style-type: none"> ▪ The relevant issue for ventilation design 	<ul style="list-style-type: none"> ▪ Consider the type of tunnel

6.1.1.2 KPE tunnel

In Singapore, an underground road such as an urban tunnel is often seen as a mobility solution to keep the people and logistic mobility moving from an origin to a destination. The scarcity of open land, the high price of open land and increasing environmental issues are some factors that drive more underground transport infrastructure such as underground MRT and expressway tunnels to meet the accessibility challenges.

An urban road tunnel in Singapore is considered a complex design due to high traffic volume and many road interchanges within relatively short distances. KPE is a 12 km long expressway that comprises a 9 km underground section (Figure 6-1). KPE tunnel is considered the longest urban tunnel in South-East Asia, with an estimated traffic volume of 400 million vehicle kilometres per year (Wong et al. 2010).

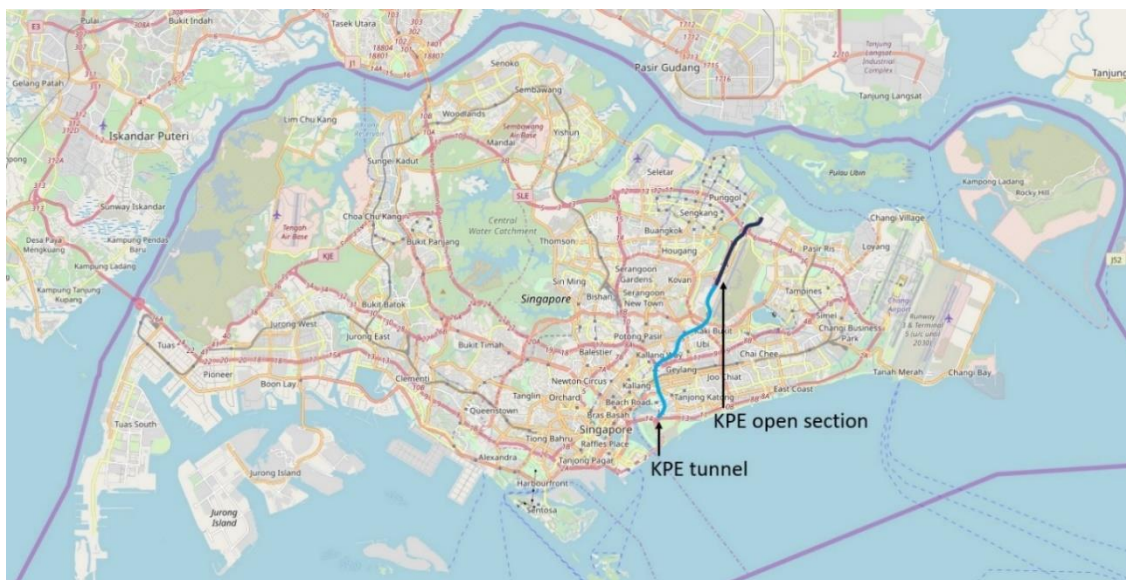

Figure 6-1: Map of Expressways in Singapore (OpenStreetMap, 2018)

The KPE tunnel connects the Northeast part area to the CBD. The first 3 km to the north is an open road section of the expressway. The remaining 9 km section to the South is underground and further connected to the Marina Coastal Expressway (MCE) tunnel. In the Southern part of the KPE tunnel, which is considered part of the CBD, the traffic flow is relatively high during peak hours. Therefore, ERP is implemented during high traffic volume in the busy section. From the end of 2013, traffic law limits the vehicle speed in the KPE tunnel to a maximum of 80 km/h, which is in line with MCE (LTA 2013b). The KPE speed limit was set at 70km/h in 2008 due to the tight bends along the KPE. Other characteristics of the KPE tunnel are explained in Table 6-2.

The tunnel has two bores separated by a concrete wall, where each bore represents an opposite direction with three lanes. On the left-hand of each bore, there is a short side

emergency walk. Emergency exits are available at every 100-meter interval. This urban tunnel is located near the business area and a residential neighbourhood.

Table 6-2: KPE tunnel characteristics (Jiangxun 2010; Yang 2014; Ming 2009; Meng et al. 2011; LTA 2014a))

1	Uniqueness	<ul style="list-style-type: none"> Urban highway Urban road tunnel (due to the high density and the scarcity of land) Attached to another main tunnel (MCE) in the Southern part High traffic flow, especially during the peak hours in the Central Business District (CBD) part Many conjunctions (exit ways and entrances or slip roads) with a comparatively short distance → 19 slip roads along a 9 km tunnel Linked to the other major roads and expressways (multiple exit ways and entrances) KPE tunnel can be divided into several sections due to its geometric and traffic flow characteristics Non-homogeneous urban road tunnel A form of notice is required to be submitted to LTA before an HDV enters the KPE tunnel
2	Traffic	<ul style="list-style-type: none"> The speed limit at 80km/h (since Dec 2013, in line with the MCE speed limit) Three lanes in each direction, plus an additional lane near the entrance and exit way Traffic volume varies from 1,000 – 1,800 vehicles/hour/lane Expected daily road users: 48,900 road users/day Expected travel time reduction by 20-30% KPE reduces island-wide travelling by up to 6% HDV range 5-30%
3	Physical	<ul style="list-style-type: none"> Two tubes, each tube consists of three lanes 9 km of cut and cover underground tunnels Six ventilation buildings (distance between 1,390 – 2,180 meters) The tunnel is not accessible to vehicle dimensions exceeding 4.5m in height, 2.5m in width or 13m in length
4	Operational	<ul style="list-style-type: none"> The tunnel is monitored 24/7 by the operation control centre, with 2-4 cameras every 200 meters A Closed-Circuit Television (CCTV) records real-time and traffic information Jet fan (guide the airflow longitudinally in the same direction as a vehicle) Six ventilation buildings are in operation (Ventilation Building A to F) → for operation and air quality control
5	Others	<ul style="list-style-type: none"> Serving the growing demand for traffic and linking the South (CBD) and North area of Singapore Vehicles carrying hazardous loads such as petrol and natural gas are also prohibited from entering the tunnel to ensure safety within the tunnel

Air quality within the tunnels is controlled by a ventilation system that enables the number of jet fans to be adjusted to the various rate of airflow through the tunnels according to traffic volumes at the time or measured pollutants concentrations at a specific temperature. The fans are operated in the same direction as the traffic flow. Additionally, the jet fans are controlled based on sensor readings in the tunnel. Once a particular parameter has reached a certain threshold level, the fans would be turned on immediately. For instance, if CO levels exceed 30 ppm, then the sensor will trigger the fan to run and if the temperature reaches 35°C, then the fans will switch on. Moreover, if the CO level reached exceeds 85 ppm or if the temperature increases to 40.5°C, the fan is activated in a fully triggered mode (see the following table for more detailed jet fans operation conditions).

Table 6-3: Jet fans operation conditions (adopted from LTA-NTU study)

30	0.27	35	Partial on
60	0.54	38	Partial on
85	0.77	40.5	Partial on
100	0.9	42	Fully triggered

The tunnel is also equipped with several ventilation buildings to move fresh air and remove stale air. The ventilation buildings have an average distance of 1.3 – 2.1 km between each other. The tunnel air velocity under natural ventilation is 3-4 m/s, and forced ventilation is 10-15 m/s (Meng and Qu 2010; Ma et al. 2011).

6.1.2 Experimental tunnel measurement

6.1.2.1 Principle and methodology

The principle of pollutant mass balances from tunnel experiments is described in Figure 6-2. An example of an ideal rectangular cross-section and length is shown. Tunnel air is moving in at the tunnel entry with a specific volume flow and background pollutant concentration. The tunnel air is leaving at the tunnel exit with a volume flow that should be identical to the tunnel entry and with a pollutant concentration that should be considerably higher than at the entrance because of the pollutant mass flow emitted by vehicles passing the tunnel (Fredrich and Reis 2014).

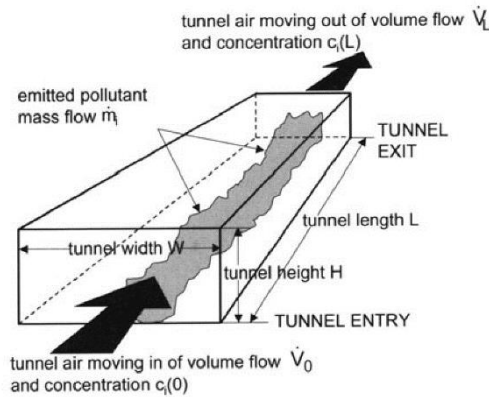

Figure 6-2: Pollutant mass balances principle from tunnel experiments (Fredrich and Reis 2014)

Tunnel studies can be used to derive aggregated real-world EFs. These may be either distance- or fuel-specific (if a carbon balance can be assumed). The EFs from tunnel measurements may be calculated according to the method of Pierson (Pierson and Brachaczek, 1983; Pierson et al., 1996);

$$EF_{veh} = \frac{C_{out} - C_{in}}{N \cdot L} A \cdot U$$

Equation 6-1

where;

- EF_{veh} : average EF, [mg/km] per vehicle travelled
- C_{in} : pollutant mass concentrations [mg/m³] at the entrance of the tunnel
- C_{out} : pollutant mass concentrations [mg/m³] at the exit of the tunnel
- A : tunnel cross-sectional area [m²]
- U : velocity of air in the tunnel [m/s]

- t : sampling duration [seconds]
N : the total number of vehicles during the sampling period
L : the distance between two monitoring stations [km].

When using this equation, one assumes that the movement of air and vehicles cause uniform mixing and distribution of the pollutants throughout the tunnel (El-Fadel and Hashisho, 2001). This equation is widely adopted in evaluating several tunnels for a similar purpose, such as Wuzushan and Kuixinghou tunnels in China (Cui et al. 2016); Grand Mare tunnel in France (Ameur-Bouddabbous et al. 2012); Chung-Liao tunnel in Taiwan (Chiang et al. 2007); Fu Guishan tunnel in China (Chen et al. 2013) and many other tunnel cases. Most of the cases are used for determining the EFs for CO, NO_x and PM for worldwide applications related to EF determination. Nevertheless, no tunnel study has established EFs for South-East Asia.

Since the tunnel is an expressway, vehicles operate under free-flow conditions. In this situation, it is also assumed that vehicles are functioning under hot-stabilised conditions. Therefore, only free flow or steady speed and hot-stabilised conditions predicted by the emissions model are compared later with the EFs derived from the EFs model.

6.1.2.2 Measurement program

The tunnel measurement program was initially a research collaboration between LTA Singapore and NTU under the “Sustainable Ventilation System for Underground System” project in 2014-2016. The main project goals were (1) monitoring the air quality inside the tunnel and (2) understanding how the traffic, ventilation system and other appearances affect the tunnel environment quality and user comfort levels. However, other possibilities, such as validation of EFs from tunnel measurement data, were possible under the supervision and permission of LTA and NTU.

The air concentrations measurements inside the KPE tunnel were conducted in two periods in November-December 2014 for the South-North direction and a year later in the same period of November 16th – December 7th, 2015, for the opposite direction. However, only the second phase data can be used to validate EFs purpose due to the unexpected data quality concerns from NTU devices (some devices did not work properly). Therefore, hereafter, only the second phase of air quality measurement is discussed.

The measurement consists of the following considerations (only related to the research proposes):

- Measurement inside the KPE tunnel is aimed to provide an aggregated Singapore fleet EFs addressing the local traffic conditions
- Tunnel measurement data provides information on the following parameters:

- Traffic flow data: number of vehicles in a time horizon;
- Fleet distribution: traffic flow and its distribution in general; passenger cars (including taxis), MCs, LDVs and HDVs;
- Traffic speed;
- Air quality concentrations data, temperature and humidity;
- Additional video traffic data recording is situated near the selected exit and tunnel entrance: average fleet distribution per Singapore vehicles category: PCs, taxis, MCs, buses, LDVs and HDVs (see Chapter 4). It is necessary to differentiate PCs and taxis into the different relevant groups for emissions calculation due to predominantly different fuel types;
- Traffic conditions video recording: drive-through tunnel video recording was automatically taken along the KPE tunnel with the CCTVs managed by the LTA's Operation Control Centre.

All the air concentrations, traffic data and other parameters are recorded and monitored in different time intervals due to the different equipment capabilities but then aggregated to the 1-hour interval for further calculations. Further measured parameters and equipment are explained in Table 6-4.

Table 6-4: Measurements of KPE tunnel study, case area: the Southbound bore of the KPE tunnel

<i>Primary data</i>				
Parameters: ○ PM ○ Temperature (T) ○ RH (relative humidity)	Particle counter ○ Lighthouse, 3016-IAQ ○ TSI, AeroTrack 9306V		On-site measurement by NTU	<ul style="list-style-type: none"> • continuously measured from Nov 16th – Dec 7th, 2015 • location 5.35 and 6.65 km (N-S)
Air pollutants: ○ CO ○ VOC ○ NOx	Multi-gas detector ○ Multi RAE, Lite	5 min (in ppm)	On-site measurement by NTU	<ul style="list-style-type: none"> • continuously measured from Nov 16th – Dec 7th, 2015 • location 5.35 and 6.65 km (N-S)
CO ₂	CO ₂ meter, CM018		On-site measurement by NTU	<ul style="list-style-type: none"> • continuously measured from Nov 16th – Dec 7th, 2015 • location 5.35 and 6.65 km (N-S)
Traffic volume	CCTV footages	60 min	LTA	
Averaged vehicle speed ○ a sample of a selected PC	OBDII	Second		<ul style="list-style-type: none"> • measured along KPE and MCE tunnel at the selected time
Classification and distribution of vehicles ○ LDV and HDV ○ PC, MC, Bus LDV, HDV	CCTV footages Regular video with the visual fleet classification	5 min 60 min	<ul style="list-style-type: none"> • LTA • Video survey on-site (near the tunnel entrance) 	<ul style="list-style-type: none"> • Traffic flow was continuously recorded from Nov 16th – Dec 7th, 2015 • Traffic video was recorded on the weekend and selected weekdays (Nov 21st, 22nd, 24th, 25th 2015 (2 hours sampling during morning and afternoon peak hours, off-peak hours)
<i>Secondary data</i>				
Classification and distribution of vehicles: PC, MC, Bus, LDV, HDV	Statistical Data	Yearly vehicle distribution trends (up to specific sub-categories)	LTA statistics, developed fleet model	

6.1.2.3 Location and equipment

The air quality concentrations measurement inside the KPE tunnel is conducted for location II at 6.65 km and location III at 5.35 km. These two locations were selected for having the highest

traffic volumes compared to other sections. The average daily traffic flow is estimated to reach around 40,000 vehicles/hour (calculated data). Besides, along that section, no slip-road is available. In this case, it is crucial to choose a section where the airflow can run smoothly in the same direction as traffic flow without any interruption of ventilation building or slip roads. A homogeneous mixture of air and pollutants concentrations was assumed inside the tunnel. The measurement was performed in the Southbound tube, which is assumed to have an approximate gradient of 1.5%. An illustration of the measurement location and the tunnel layout is presented in Figure 6-3 and Figure 6-4.

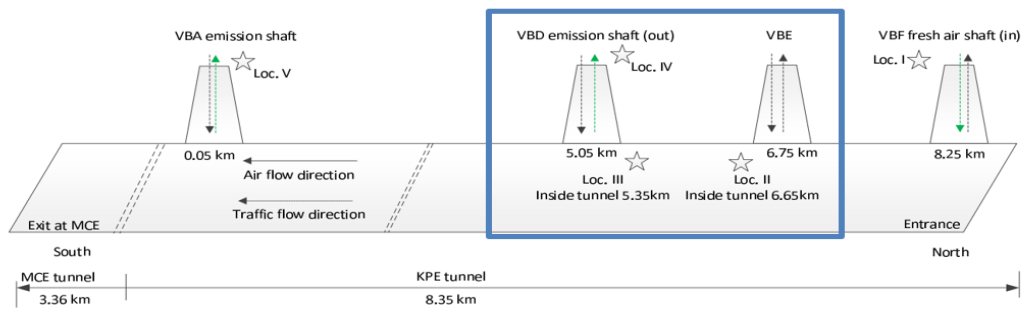

Figure 6-3: Location of the measurement (adopted from LTA-NTU study)

Air concentrations sampling was carried out continuously over 21 consecutive days from November 16th – December 7th, 2015, using two sets of harmonised instruments (Lighthouse 3016 and TSI Aero Track 9606V) at two designated locations. A complete set of instrument is placed behind the cladding on the wall's left side to avoid drivers' suspicious attention in the tunnel. Before the on-site measurement, all instruments were tested and calibrated per recommendations from the manufacturer.

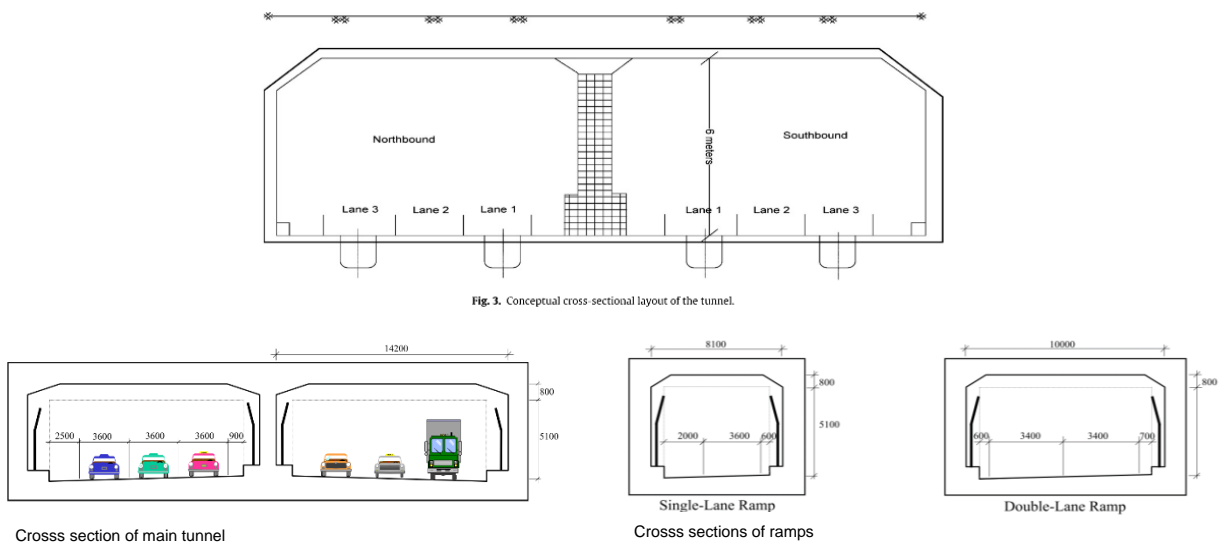

Figure 6-4: Tunnel layout (Kwa 2010)

The traffic flow was continuously recorded over 14 days within the same time interval as air concentration measurements using CCTVs installed in the tunnel for the traffic monitoring operated by KPE Operation Control Centre LTA. Additional traffic data surveys were conducted near the measurement location. Measurements were carried out for secondary data near the entrance and exit way at the KPE tunnel to identify a more detailed fleet distribution representing the local mix fleet at the KPE tunnel. Detailed measurement characteristics of the fieldwork are summarised above in Table 6-4.

6.1.2.4 Sampling and data analysis

Only valid air concentration measurements, recorded traffic flow and vehicle distribution data in both locations are used for further analysis. The weekend and weekday data were differentiated due to travel behaviours' different characteristics. Because of the particle counter's technical problem at location II during continuous measurement, only selected air pollutants of CO and NO_x are analysed in detail.

The values of traffic flow and vehicle distribution were obtained from CCTVs data operated 24 hours by LTA. However, a limitation was found in the vehicle distribution in generating hourly traffic count and vehicle composition. The taxis were included as part of PCs in the vehicle distribution. In Singapore's local context, taxis and PCs need to be differentiated because they use different fuel types that produce different air pollutants. As informed in Section 4.2.1, around 85% of taxis in 2015 were using diesel engines, whereas 97% of PCs were using gasoline to run the engine. An adjustment of vehicle distribution was taken based on secondary data from several hours of video sampling at the selected entrance and exit near the measurement spot. The vehicle distribution of video sampling was counted manually on 5 minutes basis for every 10 minutes of the recorded video.

EFs (g/veh-km travelled) for aggregated vehicles were calculated for every parameter. Each time segment interval was calculated using Equation 6-1 with the following constant parameters: $A = 83.78 \text{ m}^2$, $U = 8\text{m/s}$ (assumed) at the normal working condition, $t = 3600$ seconds, and $L = 1.3 \text{ km}$. Others dynamic parameters were pollutant concentrations (C_{in} , C_{out}), and the number of vehicles (N) was based on the field measurement.

6.1.3 Preliminary results

6.1.3.1 Observed traffic data

The hourly vehicle counts were recorded automatically by computer-analysed CCTV footage alongside the air quality measurements. A few weeks later, the traffic data was shared by LTA, consisting of automatic vehicle counts and vehicle distribution. The quality of data was checked to ensure data reliability. Unfortunately, there were unrecorded data for some hours within the

time frame. Therefore, only valid data (86% weekdays and 40% weekends data) is used for this calculation to avoid a biased result.

The traffic flow pattern in the tunnel was differentiated into weekday and weekend patterns. Only Tuesday, Wednesday, and Thursday data were selected as a typical weekday pattern. For the weekend pattern, mainly Saturday data was used since the quality of Sunday's data was insufficient for analysis (no complete 24 hours Sunday data was available).

The overall average daily traffic volume for the weekend was around 4% higher than the weekday, most likely due to additional off-peak cars³ (especially weekend cars) on the road. The traffic flow profile during the weekday demonstrated a daily traffic flow trend with two different peak hours; morning peak hour (07.00–09.00) and evening peak hour (17.00–20.00), as shown in Figure 6-5. However, another small peak during the afternoon (13.00–15.00) was also found. Unlike the weekday trend, weekend traffic flow behaviour showed a different pattern. The motorists' travel activities started a bit late in the morning, but the flow remained stable from 09.00–13.00, slowed down in the afternoon for some hours (13.00–16.00), slowly increased, and peaked at 18.00. The average hourly traffic flow during the morning peak (07.00–08.00) on a weekday was 5,205 vehicles/hour, while at the weekend, the peak shifted to the afternoon (18.00–19.00) with 3,200 vehicles/hour.

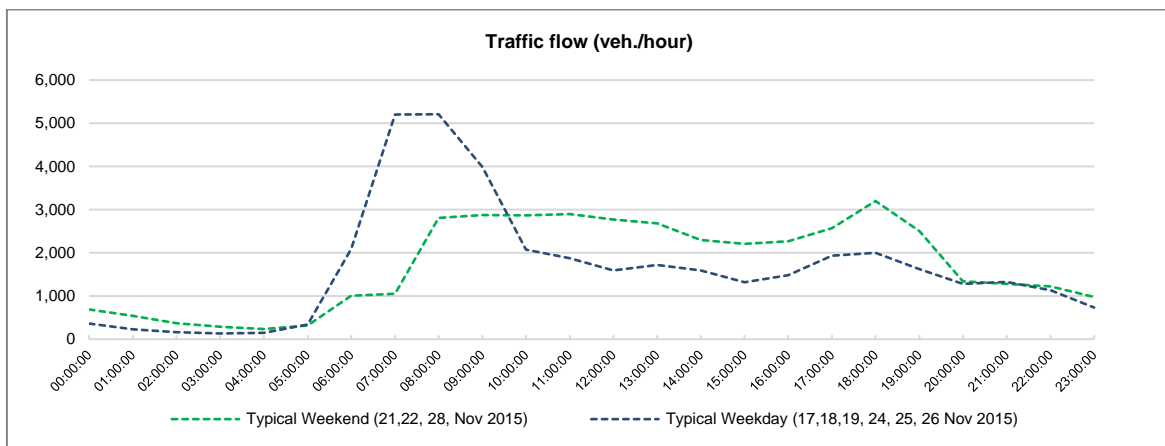

Figure 6-5: Typical traffic flow between 5.35 and 6.6 km at the KPE tunnel

As mentioned in 6.1.2.2 and 6.1.2.3, vehicle distribution was gathered from two different sources; (1) computer-analysed CCTV footage operated 24 hours by LTA and (2) manual traffic video collection at the nearest entrance and exit way to the measurement spot. Manual data collection was expected to get a better fleet description.

³ Off-peak cars or red plates are cars under the following schemes: Weekend Car (WEC), Off-Peak Car (OPC) and Revised Off-Peak Car (ROPC). There are different restrictions on the usage hours for cars under the different off-peak car schemes ([One Monitoring](#)).

Figure 6-6 shows the trend of vehicle distribution and traffic flow inside the tunnel captured by CCTV footage for daily average weekday and weekend traffic patterns. The vehicle categorisation was too general, differentiating only between MCs, PCs, LDVs and HDVs. The PCs category contributed the most significant share, with an average percentage of 78% on weekdays and 80% on weekends. LDVs followed with an average share of 18% on weekdays and 16% on weekends. MCs contributed a small percentage of around 3% for both weekdays and weekends. Unpredictably, HDVs' share was meagre, with a value of almost 0%.

Some uncertainties were found in the traffic flow data and vehicle distribution derived from LTA. One of the issues was that the PCs had to be differentiated into actual PCs and taxis due to predominantly different fuel types. Another issue is the underestimated share of HDVs. Therefore, another vehicle distribution was generated manually as backup data based on video recording at the entrance and exit way of the KPE tunnel. This additional data is to be used as an adjustment factor to improve the reliability of vehicle distribution data generated by CCTV footage.

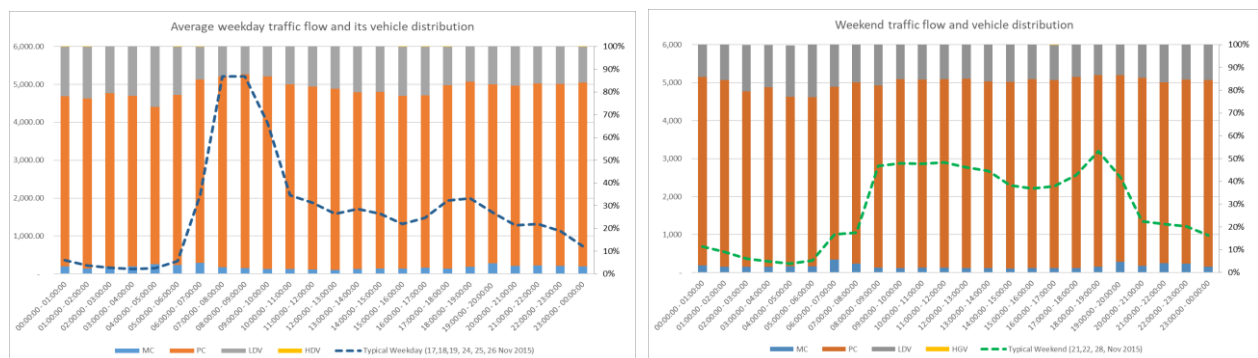

Figure 6-6: Weekday and weekend traffic flow and its vehicle distribution based on CCTV footage inside the KPE tunnel

Figure 6-7 and Figure 6-8 explain the traffic flow and its vehicle distribution based on video recordings near the tunnel exit and entrance. The distribution is divided into PCs, MCs, taxis, LDVs, HDVs, public buses, private buses and minibuses. The vehicle distribution of two typical weekdays proves a similar trend in each hourly slot. In this case, the behaviour of vehicle distribution during both weekdays was likely the same. PCs (around 58%) were predominated by PCs, followed by LDVs, MCs, taxis, HDVs and minibuses, whereas both bus types contributed a less significant share.

For the weekend trend in Figure 6-8, the vehicle distribution presented a different behaviour on Saturday and Sunday, especially during the morning hours. On Saturday morning, the trend displayed a significant movement of LDVs with up to 29%, whereas the distribution of LDVs was double that of the situation on Sunday morning. During morning time on the weekend, passenger cars' distribution was 1/3 of the average working days.

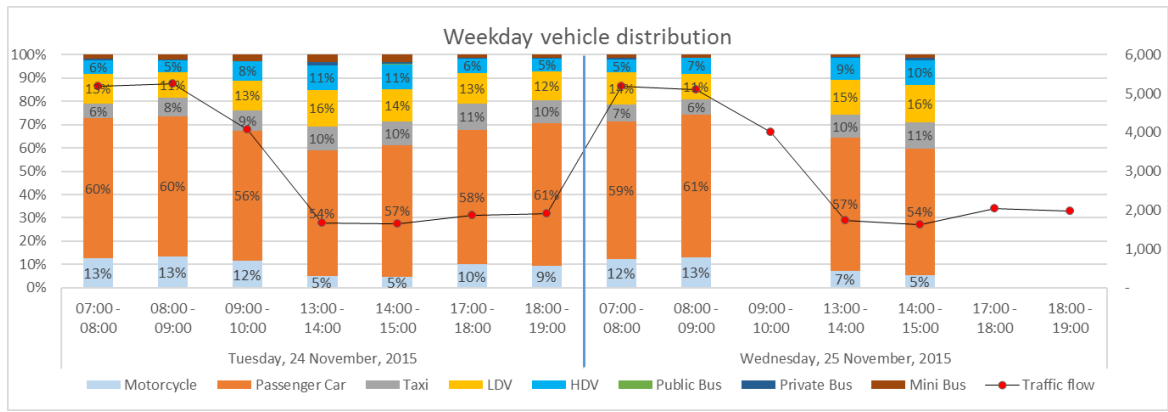

Figure 6-7: Weekday traffic flow and its vehicle distribution based on video recording near the KPE tunnel exit and entrance

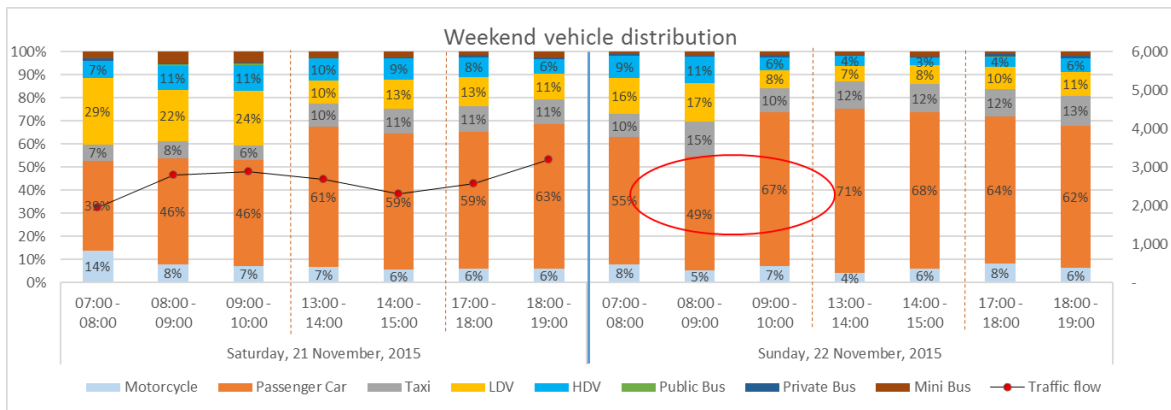

Figure 6-8: Weekend traffic flow and its vehicle distribution based on video recording near the KPE tunnel exit and entrance

There were some differences regarding vehicle distribution results among two different approaches, as shown in Figure 6-6, Figure 6-7 and Figure 6-8. The average share of PCs, MCs, LDVs, and HDVs, differed between approaches, as shown in Figure 6-9. A significant highlight was found in the high contribution of HDVs based on the video recording (manual counting) with around 10% higher contribution than measured in the CCTV footage. Besides, the share of MC was also underestimated by CCTV footage. This fact may be due to the MCs being hidden by other motor vehicles inside the tunnel so that CCTVs could not capture them adequately.

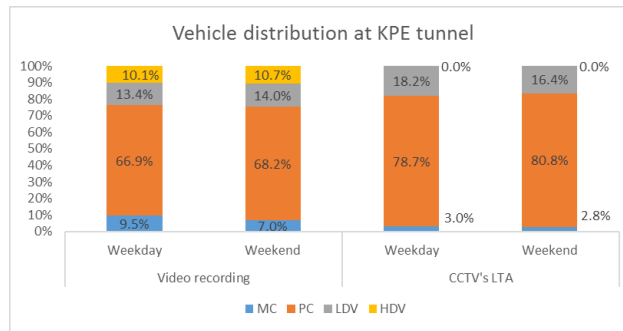

Figure 6-9: Comparison of vehicle distribution using two different approaches (CCTV and video recording)

Based on this result, the automatic processing of vehicle distribution did not work well, especially for the research purpose. However, the vehicle counts data were still valid and helpful for further analysis. For this reason, the vehicle distribution data generated from LTA's CCTVs needs to be adjusted to the vehicle distribution data captured by secondary video recording.

Figure 6-10 describes the different share of vehicle distribution of the national population and the percentage of vehicles driving at the KPE tunnel. Vehicle share distribution at the KPE tunnel corresponded to the real travel activity, with the highest share of the taxis driving through the tunnel.

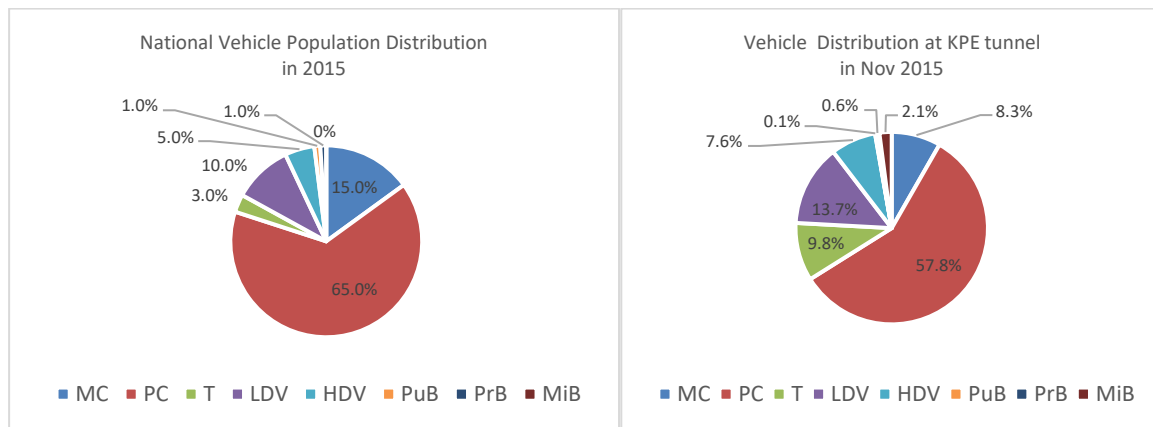

Figure 6-10: Comparison of the national population and KPE tunnel vehicle distribution

According to a study conducted by NTU-LTA, the average speed of the KPE tunnel is usually between 70-80 km/hour (speed limit of 80 km/hour). However, during the morning rush hour, the vehicle speed decreased to 45-60 km/hour. The real-time vehicle speed was not recorded during the measurement. However, the average vehicle speed is predicted using the speed-flow relationship of Singapore tunnels (source: NTU) with a result of 78km/h.

6.1.3.2 Tunnel environment conditions and pollutants concentrations

(1) Temperature

The average temperature inside the KPE tunnel was around 30-37°C. Generally, the temperature inside the tunnel was higher by about 1-8°C compared to the ambient temperature outside the tunnel.

(2) Relative humidity

The relative humidity inside the tunnel was about 50-70%. It was lower than outside ambient conditions with a range of 60-100%.

(3) Carbon monoxide

CO is emitted from motor vehicles under incomplete combustion conditions. Therefore, CO is often used as an indicator for assessing the ventilation system performance in a long tunnel. Figure 6-11 below shows that the CO concentrations during weekday morning peak hours were 10.27 - 13.15 ppm, while during weekend peak hours were 4.50 - 6.25 ppm. However, during the weekend, the CO concentrations were relatively constant during the day due to different weekend travel behaviour. The concentrations inside the tunnel at 5.35 km were visibly higher than at 6.65 km, with an average ratio of 1.26 - 1.30 during weekdays and weekends. The piston effect (the forced air flow generated by moving vehicles within a tunnel or shaft) impacted the CO concentrations along the tunnel.

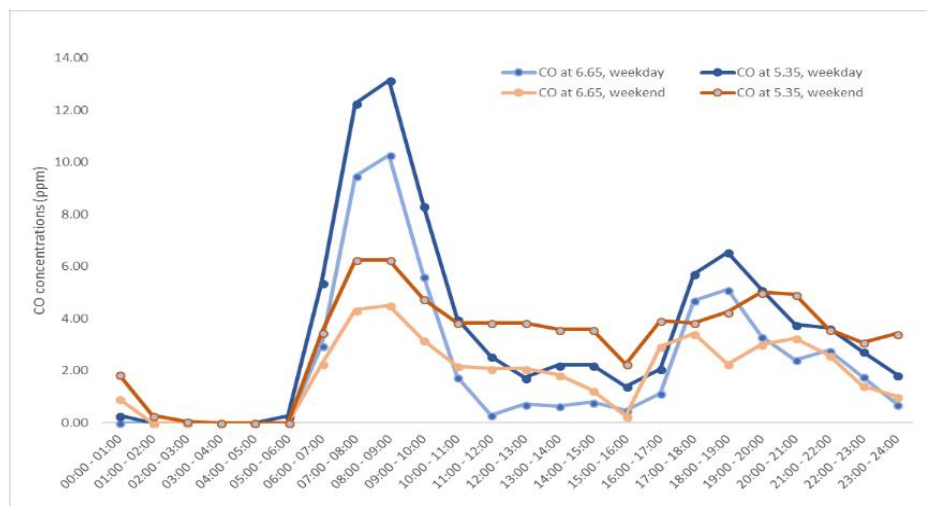

Figure 6-11: The diurnal variation of CO concentrations during weekday and weekend

(4) Nitrogen oxides (NO_x)

NO_x (NO and NO₂) is an essential air pollutant from mobile sources, especially from diesel engine exhaust. Generally, NO_x emissions typically consist of 85-95% NO and 5-15% NO₂ (Soltic and Weilenmann 2003). While (Ma et al. 2011) did a similar study at Hsueh-shan Tunnel in Taiwan, they found that the NO_x composition is dominated by NO, which

constitutes 96-99% of the NO_x . Another tunnel study conducted by (Cheng et al. 2006) in Hong Kong identified that NO represented around 70-80% of total NO_x .

As shown in Figure 6-12, the NO concentrations were higher at 5.35 km than the concentrations at 6.65 km. These concentrations were affected by the traffic flow direction and piston effect inside the tunnel. During peak hours on weekdays and weekends at 5.35 km, maximum NO concentrations were 1.89 ppm and 1.50 ppm, respectively.

For NO_2 concentrations, the resolution of the equipment is 0.1 ppm. According to the recorded NTU data at 5.35 km and 6.65 km, the concentrations were primarily recorded at level 0 ppm. Zero values mean the concentrations of NO_2 were below 0.1 ppm. Only a few data were recorded at level 0.1 ppm. The share of NO_2 at the KPE tunnel is about 3-5% based on data analysis. Hereafter, NO is discussed in more detail, while the total NO_x is adjusted according to the minor share of NO_2 and a significant share of NO.

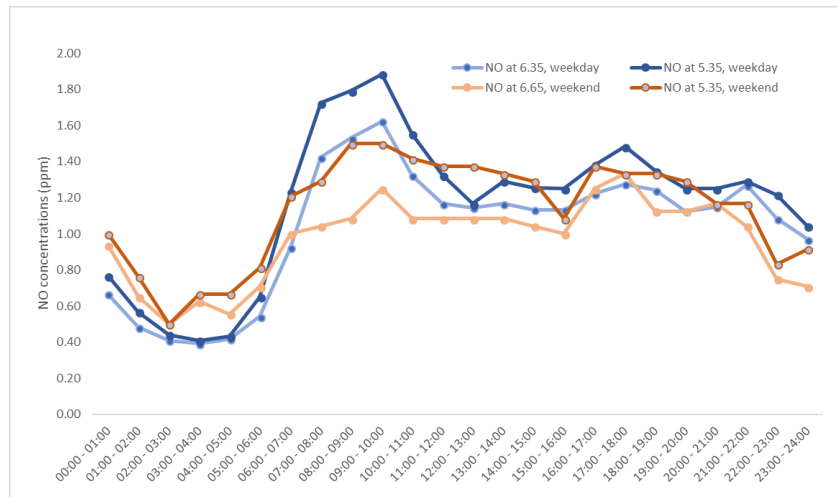

Figure 6-12: The diurnal variation of NO concentrations during weekday and weekend

6.1.3.3 The relationship between traffic flow and pollutants concentration

The concentrations increment of CO and NO present an approximately linear relationship with traffic flow, as shown in Figure 6-13 and

Figure 6-14. The R-square value, square of the relative coefficient, of the relationships between CO and NO concentrations and traffic flow, were about 0.57-0.82 and about 0.54-0.64. Weekday measurements showed higher traffic flows with higher CO and NO concentrations.

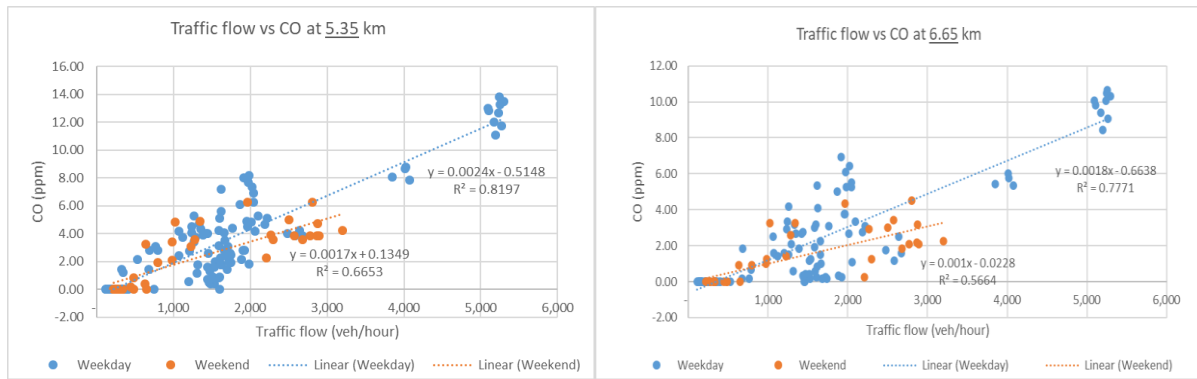

Figure 6-13: The relationship between CO concentrations and traffic flows on the weekend and weekdays

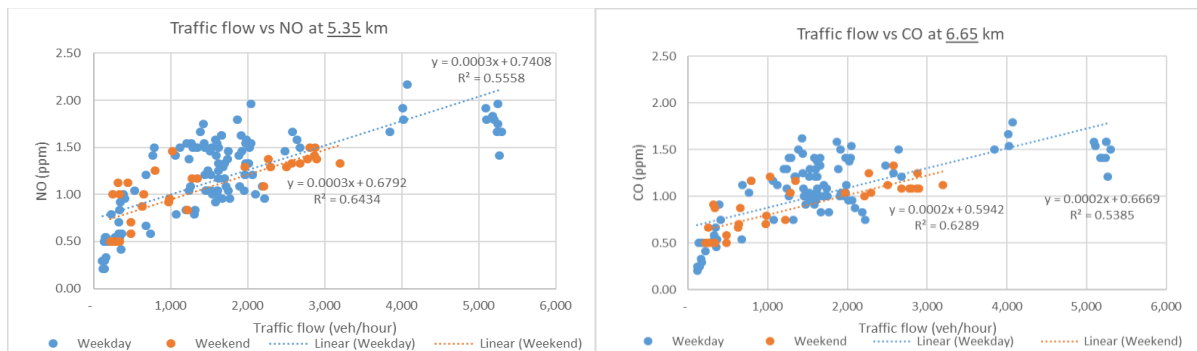

Figure 6-14: The relationship between NO concentrations and traffic flows on the weekend and weekdays

6.1.4 EFs estimation

6.1.4.1 Dependence of EFs on speed

There was no accurate measurement of actual speed on-site during air concentrations and traffic data collection. Still, the average speed estimation can be gathered from a speed-flow relationship from the KPE tunnel recorded in recent years as developed by NTU researchers. Based on the speed-flow relationship for the KPE tunnel, the average speed is around 78 km/h, and it varies through the day according to vehicle flow in a lane which is represented in the vehicles/hour lane. Various speeds were used in the calculation based on the respective traffic flow.

6.1.4.2 Calculated EFs of CO and NO

The average CO and NO concentrations and calculated EFs are listed in Table 6-5. The EFs of CO averaged 1.46 g/veh.-km and NO 0.27 g/veh.-km. The average EFs are considered the small fraction of diesel vehicles at about 10%. In total, 143 sampling hours were collected for measurement. 60% of the total collected hours were selected as acceptable data.

Table 6-5: Concentrations and calculated EFs of CO and NO in the KPE tunnel

			CO	NO	CO	NO	CO	NO
Weekdays	108	78	2.32	1.03	3.59	1.17	1.41	0.27
Weekend	35	79	1.94	0.97	3.16	1.13	1.49	0.26
Total sampling hours	143				Average EFs		1.46	0.27

The motorised emissions in the KPE tunnel also represent the level of emission standards implementation and strict inspection and maintenance procedures in Singapore. However, the calculated EFs included errors in concentration measurement (instruments, technical installation), automatic vehicle number counting, vehicle distribution, and airflow. According to the screening quality of measurement data, the estimated maximum range of errors of EFs for CO and NO_x was about 5-10% (according to the screening quality of measurement data). The suspected major factors of errors were instruments and airflow.

6.1.4.3 EFs comparison with previous tunnel studies

The EFs in this study are compared with previous tunnel studies on different sides of the world by considering the LDVs (gross weight ≤ 3.5 tons) or gasoline fraction listed in Table 6-6. The comparison also considered the following characteristics; operating conditions (free flow, congestion, bound flow), year of the experiment, average speed, and typical fleet (Gertler and Pierson 1996). It also indicates that tunnel measurements have been proven consistently over time as a method that is still valid to confirm the emissions models as part of a real-world measurement.

The EFs trends determined in this study were consistent with other studies in Asia, Europe and the US. The EFs gathered from the KPE tunnel were one of the lowest compared to other tunnel studies because the applied year is 2015 when Singapore applied for Euro 6 for gasoline and Euro 5 for diesel for LDVs and HDVs (see Chapter 3). Another important consideration for the KPE tunnel case is the fraction of LDVs in the tunnel with a 90% share of LDVs, and among them, 10% comprising diesel (taxis). Furthermore, the government implemented several strong policies such as CEVS, a 10-year vehicle scrapping policy (average fleet age in 2015 was about 6-7 years for PCs), one of the highest motor vehicle taxes globally, an early turnover scheme, and a strict motor vehicle inspection and maintenance.

It is not possible to compare the derived EFs case by case since every tunnel has its local characteristics (such as the country's specific policies, test year, experimental methods, fleet composition, and speed limits). Besides, other technical factors reflecting the difference of EFs in the tunnels are traffic flow and the share of HDVs. As blue highlights in Table 6-6, repeated

tunnel cases were found in Switzerland's Gubrist tunnel. According to (Colberg et al. 2005), the measurements were started for this tunnel in 1990, with the long-term comparison between derived EFs and the EFs based on the HBEFA emissions model. A long-term EFs' tunnel comparison is also used to document the successful introduction of a policy such as controlled catalysts in the Swiss (European) fleet.

Table 6-6: Comparison of pollutants EFs in g/km-veh. with other tunnel studies

KPE Tunnel - SG (this study)	Gasoline 80% or LDV ^a 90% ($\pm 10\%$ taxi)	2015	222,399	70-80		1.46	0.28	
East Yan'an Road Tunnel - CN (Huang et al. 2017)	LDV 94%	2016				1.84 \pm 0.90	0.40 \pm 0.25	
Loma Larga Tunnel - MX (Mancilla et al. 2012)	LDV 97%	2009	108,567	48-59	3.59%	4.83 \pm 2.90	0.11 \pm 0.07	
Hsuehshan Tunnel - TW (Chang et al. 2009)	LDV 100%	2006		50-70	1.23%	0.91 \pm 0.47 1.47 \pm 0.63	0.14 \pm 0.67 0.33 \pm 0.17	Downslope Upslope
Chung Liaou Tunnel - TW (Chiang et al. 2007)		2005				1.89 \pm 0.56	0.73 \pm 0.15	Motorway, max speed 110 km/h
Bidirectional Bus Tunnel in Brisbane - AU (Lechowicz et al. 2008)	Bus 100%: 66% diesel, 34% CNG	2005				8.10 \pm 1.40	15.90 \pm 3.70	
Shing Mun Tunnel - HK (Cheng et al. 2006) - Diesel veh. - Non-diesel veh.	Diesel 30-60%	2003/ 2004		60-70		1.85 \pm 0.43	0.88 \pm 0.31 1.93 \pm 0.31 0.08 \pm 0.28	Mean
Gubrist Tunnel - CH (Colberg et al. 2005)	100% LDV (88% passenger cars + 12% delivery vans) 100% HDV	2002		90	1.3%	1.4 n.a	0.35 10.8	
Taipei Tunnel - TW (Hwa et al. 2002)		2000				3.64 \pm 0.26	0.90 \pm 0.18	
Chung-Cheng Tunnel - HK (Hsu et al. 2001)		1999			6%	6.25	1.02	
Gubrist Tunnel - CH (Stahelin et al. 1994)	LDV 76-99% HDV 100%	1993		90	1.3%	3.9 n.a	1.1 15.3	
Tuscarora Tunnel - US (Pierson et al. 1996)	LDV 82%	1992	5,928	88-69	0.00%	3.04 \pm 0.30	0.24 \pm 0.16	
Ford McHenry Tunnel - US (Pierson et al. 1996)	LDV 90%	1992	26,665	60-85	3.30%	3.95 \pm 0.34	0.50 \pm 0.06	
Van Nuys Tunnel - US (Pierson et al. 1990)		1987		21 66		25.47 13.05	0.78 0.99	
Allegheny tunnel (Pierson et al. 1990)	LDV 100%	1981 ^b 1979 ^b		88 88		10.37 8.88	1.18 -	

Note ^aLDV gross weight \leq 3.5 ton; ^bSummer.

6.1.4.4 Comparison of determined EFs with EFs models

The following Table 6-7 summarises a comparison of this KPE tunnel study with COPERT EFs that have been used in Chapter 5 for emissions inventory purposes. COPERT's EFs for typical conditions are based on detailed measurements clustered for typical highway and speed driving conditions (such as measured by a dynamometer test at a laboratory for a specific vehicle type and done for legislative driving cycles like NEDC, using an average speed approach in a given fleet year).

As listed in Table 6-7, COPERT's EFs have higher values than the estimated EFs performed in the case of the KPE tunnel. The KPE fleet appears to be cleaner than supposed by COPERT for the European fleet. However, verification is needed due to uncertainties found, such as accurate fleet distribution and air flow velocity inside the tunnel. The available fleet distribution (vehicle type) in the tunnel is based on video camera data collected at several peaks and non-peak hours. Furthermore, according to the calculated EFs derivation from COPERT, the vehicle distribution obtained from the national transport statistical data (vehicle type, fuel type, segment type, and Euro emission standards) was assumed to be specific.

Table 6-7: Comparison of determined EFs with EFs from COPERT model

KPE tunnel	Singapore	2015	1.46	0.27	0.28	Urban LDV (PC+MC+T+LDV) 90%
COPERT (Chapter 5): specific for EF in highway	Singapore	2015	1.83	-	0.64	Urban LDV (PC+MC+T+LDV) 90%
EF difference (KPE tunnel/COPERT)			0.79		0.43	

Note: Share number of NO₂ at KPE tunnel: 3-5%, for the calculation, NO₂ is assumed 5%

Based on the result, the EFs difference can be used as a correction factor for NO_x and CO emissions estimation in other tunnel cases due to the same specific traffic condition. However, it is too early to agree that the EFs difference can be used as a correction factor in a larger-scale emissions estimation (e.g. emissions inventory). More real-world measurements are needed using various methods by conducting measurements at different road types and traffic situations.

6.2 Open road measurement

6.2.1 Open road measurement and its characteristics

Unlike tunnel studies that have been implemented since the 1980s with around 60 tunnel cases as a proven method to assess the EFs, the open road studies have only limited applications due to the complex circumstances, especially the uncontrolled conditions such as meteorological situations and the possibility of dilution and dispersion of air pollutant concentrations. Table 6-8 explains the advantages and disadvantages of open road studies.

Table 6-8: Advantages and disadvantages of EFs assessment at open road study

Traffic	<ul style="list-style-type: none"> ▪ Captures of on-road vehicle fleet representing different real-world scenarios ▪ Captures different road types and traffic conditions 	<ul style="list-style-type: none"> ▪ Need automated video counts (continuous measurement) (Ketzel et al. 2003) ▪ Depending on the road type (e.g. expressway), vehicle engines are usually conditioned at a steady temperature mode
Meteorological	<ul style="list-style-type: none"> ▪ (n/a) 	<ul style="list-style-type: none"> ▪ Uncontrolled meteorological parameters (e.g. wind speed, wind direction)
Air pollutants	<ul style="list-style-type: none"> ▪ (n/a) 	<ul style="list-style-type: none"> ▪ Measuring pollutant concentrations for upwind and downwind (Sucharov and Brebbia 2000) ▪ Depending on where the air quality monitoring is positioned, it is difficult to separate the contribution of the local traffic sources and the variation in the ambient. (Ketzel et al. 2003) ▪ Dilution and dispersion of air concentration issues
Operational	<ul style="list-style-type: none"> ▪ Low-cost methods when the monitoring is conducted in cooperation with related institutions using high-performance air quality monitoring stations and wind stations. Such studies have been conducted by (Ketzel et al. 2003) 	<ul style="list-style-type: none"> ▪ Continued monitoring in mid-long period (3-12 months) for better data statistics ▪ Ambient stations should be located in a clean environment (remote from other pollutants sources), at several distances (rural ambient stations) up to 30 km (Ketzel et al. 2003)
Other	<ul style="list-style-type: none"> ▪ Easier to get a measurement permit compared to tunnel cases 	<ul style="list-style-type: none"> ▪ Scarce literature compared to tunnel cases

6.2.2 Principle and methodology

The mass balances theory is illustrated for open roads in Figure 6-15. The road section on the ground and the complete exhaust plume are enclosed in an imaginative box. Two vertical measuring lines are positioned at the roadside, one upwind and one downwind of the road. It is necessary to determine the pollutant mass flows entering at one side (X_1) and leaving at the opposite side (X_2). Vertical wind and pollutants concentration profiles must be measured because the wind speed is perpendicular to the road and pollutants concentrations are not expected to be homogenous with height z (Fredrich and Reis 2014).

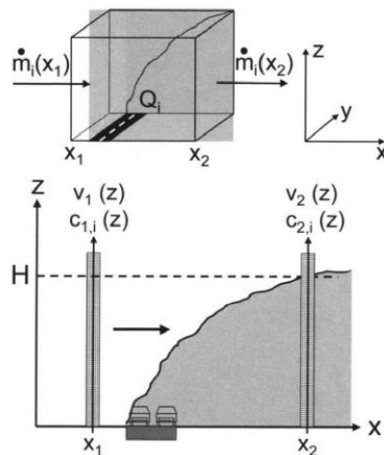

Figure 6-15: Principle of pollutant mass balances from an open road experiment (Fredrich and Reis 2014)

The mathematical description (Fredrich and Reis 2014) for the input of measurement data to obtain the EFs is provided in Equation 6-2.

$$EF_i = \frac{\int_0^H v_2(z) \cdot c_{2,i}(z) dz - \int_0^H v_1(z) \cdot c_{1,i}(z) dz}{n} \quad \text{----- Equation 6-2}$$

where:

- EF_i : mean emission factor per vehicle and pollutant i [g/m]
- $v_1(z)$: upwind wind speed at height z [m/s]
- $v_2(z)$: downwind wind speed at height z [m/s]
- $c_{1,i}(z)$: upwind concentration of pollutant i at height z [g/m^3]
- $c_{2,i}(z)$: downwind concentration of pollutant i at height z [g/m^3]
- H : height of exhaust plume [m]
- n : traffic flow [l/s]

For comparisons of real-world EFs with EFs model derived from laboratory measurement, additional input data are needed, such as manual counts of disaggregating total vehicle flow into different vehicle categories.

6.2.3 Experimental open road measurement

6.2.3.1 Field experiment

Short-term simultaneous air quality monitoring and traffic survey were conducted at selected times representing rush and non-rush hours. Continuous measurements were not possible due to the limited equipment power time range and human resources. Contamination from other sources (such as industry) near the receptor (air quality monitoring points) is assumed negligible.

6.2.3.2 Monitoring the air quality and traffic condition

Equipment

Monitoring equipment consisted of air quality, traffic survey and meteorology devices (Table 6-9). All equipment was tested before conducting the measurement in the field. Air quality monitoring equipment required a proper set-up, collocation and a full charge before moving to the field. A video camera was installed in the field to record the traffic situation. The recorded traffic video was counted manually on-site in selected five minutes intervals, and then hourly traffic volume and traffic distribution were extrapolated and estimated. Meteorological parameters are positioned near air quality monitoring equipment 40 – 80 cm higher than air quality monitoring equipment, depending on the location. All equipment was placed in a safe and secure place at the location.

Table 6-9: Air quality monitoring, meteorological and traffic survey equipment

Optical particle counter (OPC)	<ul style="list-style-type: none"> Lighthouse, 3016-IAQ TSI, Aero Track 9306-V 	PM, temperature, relative humidity
MultiRae gas detector (MR)	MultiRAE, Lite	CO, VOC, NOx
Pocket weather tracker (WT)	Kestrel 4500	Wind speed, wind direction, temperature, humidity
Camera recorder + SD card	SONY HDR – CX 240	Vehicle distribution and traffic flow
Battery (AC - Power) and power inverter to support particle counter and multi-gas detector		

Three boxes were located on-site at every designated location. Each box (38 cm x 25 cm x 35 cm) consisted of the equipment listed in Table 6-10. The two boxes were positioned at each side of the roadside to monitor the air quality. Either result box 1 or box 2 was used depending on the reliability of wind direction and pollutant concentrations.

Table 6-10: Equipment boxes

Aim: To record the air quality data and traffic flow Equipment: <ul style="list-style-type: none"> Optical Particle Counter (OPC) Multi-gas detector (MR) Weather tracker (WT) Video camera Tripod Traffic form Battery Power inverter 	Aim: To record the air quality data and traffic flow Equipment: <ul style="list-style-type: none"> OPC MR Video camera Tripod Traffic form Battery Power inverter 	Aim: To record the ambient air quality data without traffic activity intervention. Equipment: <ul style="list-style-type: none"> OPC MR WT Battery Power inverter
---	---	---

Sampling location

The air quality monitoring and traffic survey were conducted at different locations (see Figure 6-16 and Figure 6-17 for the detailed location):

- (1) Ayer Rajah Expressway (AYE) - Clementi (expressway, non-central business district area); 1.306412, 103.767666
- (2) AYE – Pandan Garden (expressway, non-central business district area); 1.306412, 103.767666
- (3) Nicoll Highway (major arterial road); 1.301568, 103.864859
- (4) Bukit Batok East Avenue 5 (minor arterial road); 1.355322, 103.753204

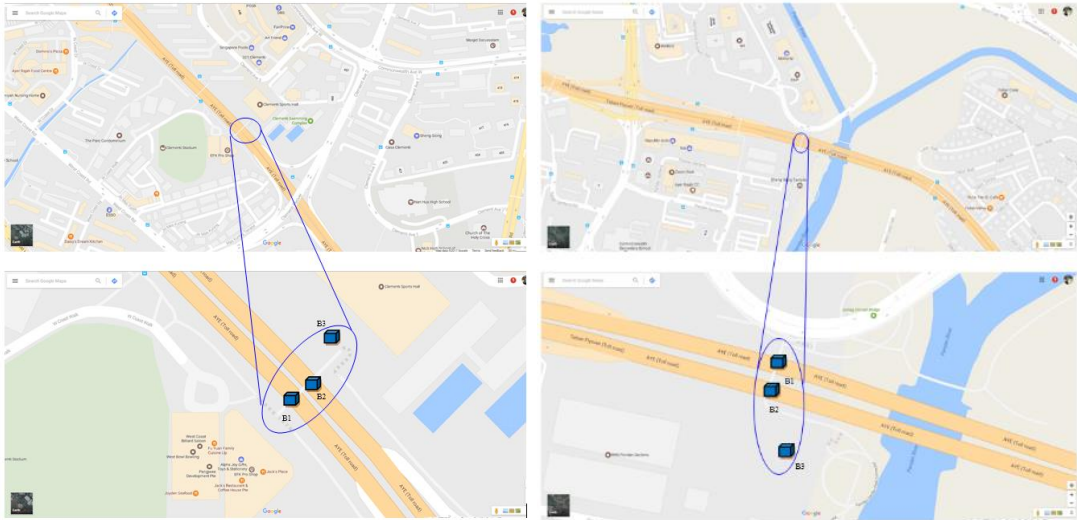

Figure 6-16: Location of open road measurement at AYE – Clementi Sports Hall, at the pedestrian bridge (left) and AYE – Pandan Garden, at non-motorised transport (NMT) bridge

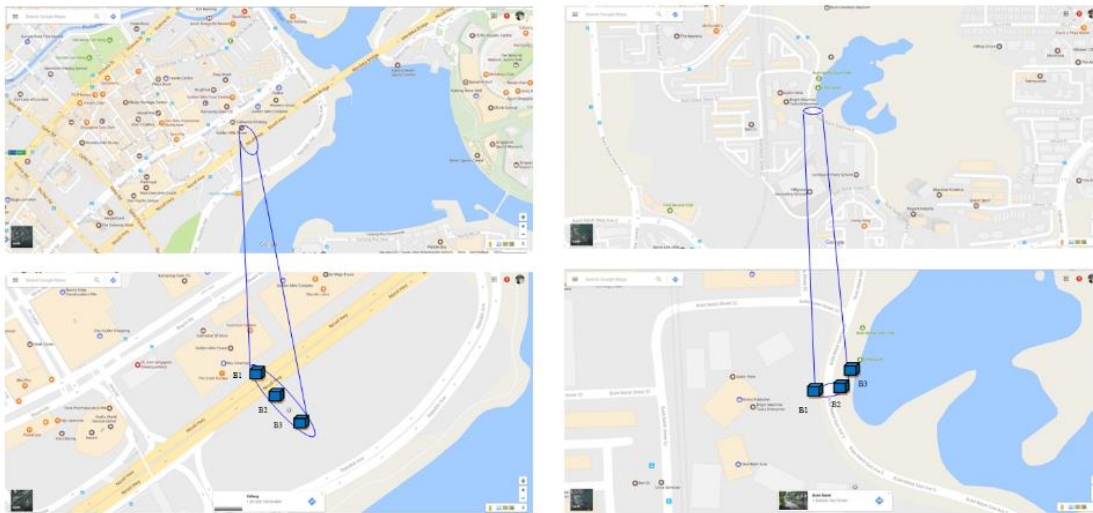

Figure 6-17: Location of the experiment at Nicoll Highway, at the roadside, green area near footpath (left) and Bt Batok East Ave 5, at the roadside, green area near footpath (right)

Equipment setting at Bukit Batok East Avenue 5 is described in Figure 6-18, Figure 6-19 and Figure 6-20.



Figure 6-18: Location (4), box 1: air quality monitoring instrument (wind tracker, particle counters, and multi-gas detector)



Figure 6-19: Location (4), box 1 (left) and box 2 (right)



Figure 6-20: Location (4), box 3 (left), video recording at box 3 (right)

Time

Air quality measurement covered rush hours and off-peak hours on three weekdays and weekends from mid-January to mid-February 2017. Measurements were conducted several times to introduce different varieties of vehicle composition and traffic flow characteristics. Tuesday, Thursday, Saturday, and Sunday were the proposed days for conducting a measurement. However, due to the restricted availability of air quality monitoring equipment and weather conditions, measurements were also conducted on other days.

Not all equipment was always in operation due to several factors, such as occasional equipment misreading and unexpected rain and wind conditions. Therefore, the time slot duration recorded

by the equipment varies per measurement. A data set of 12 complete measurements from the four data points was obtained over nine days, with around 24 total sampling hours (Table 6-11). This complete subset of the available data is listed here. The recorded data was checked to ensure reliability before being used in further analysis.

Table 6-11: Selected air quality monitoring and traffic data points in the field

No.	Date	Time slot	Location
1	Wed/ 18.01.17	18.30 – 19.30	E – AYE – NUS HS
2	Thu/ 26.01.17	17.30 – 20.30	E – AYE – NUS HS
3	Wed/ 01.02.17	16.15 – 18.15	E – AYE - Clementi
4	Fri/ 03.02.17	17.20 – 18.40	E – AYE - Clementi
5	Sat/ 04.02.17	09.30 – 12.15	E – AYE P. Garden
6	Thu/ 09.02.17	07.15 – 09.15	E – AYE - Clementi
7	Thu/ 09.02.17	10.15 – 12.30	E – AYE P. Garden
8	Thu/ 09.02.17	17.30 – 18.20	E – AYE - Clementi
9	Sat/ 11.02.17	11.00 – 15.00	Min. art. Bt. Batok East Ave 5
10	Tue/ 14.02.17	15.15 – 18.15	Maj. Art Nichol H.
11	Wed/ 15.02.17	09.00 – 11.30	Min. art. Bt. Batok East Ave 5
12	Wed/ 15.02.17	15.00 – 19.00	Min. art. Bt. Batok East Ave 5

Note: Road types: E- expressway, Maj. Art – major arterial road, Min. Art – minor arterial road.

6.2.4 Results

Raw data from different open road measurements are screened and analysed. Not all equipment provided reliable data quality for further analyses. As a result, only 4 among 12 data points can be used in the analysis, and this is also limited to particular time slots and pollutant types.

However, only selected air quality measurements are taken and discussed next to get the lessons learned for the methodology used. The measurement sample was taken at Bukit Batok St. 52 (minor arterial road, two directions, one lane for each direction) on Wed, February 15, 2017, during non-peak morning hours from 9.00-11.30. Air quality monitoring stations were taken from three locations represented by instrument boxes (Figure 6-18, Figure 6-19 and Figure 6-20); two boxes were located at each roadside, and one box was located at around 7 meters in the green area to measure the ambient concentrations. The instrument receptors' were positioned at a height of 0.4 m from the ground.

Traffic data

A video recorded the vehicle counts, and then for analysis, five-minute traffic flow intervals were counted every 30 minutes for interpolation into hourly traffic flow data. The traffic condition at the location was observed as a free flow condition with an estimated hourly traffic flow of 624 and 573 vehicles/hour during morning off-peak hours (09.00-10.00 and 10.00-11.00).

Meteorological conditions and pollutant concentrations

(1) Temperature and humidity

Several types of equipment simultaneously recorded the temperature and humidity in one-minute intervals with varying results. The average temperature rose slowly from 24°C to 28°C within the period, and the weather was cloudy. The measured relative humidity was about 82-94%.

(2) Wind speed and direction

The wind speed range was monitored using wind trackers 1 and 2 at (0.0 -1.5 m/s) and (0.0 - 3.1 m/s). Both boxes were located on different roadsides with an estimated distance of 9 meters. Both wind trackers showed a different wind direction with an average direction of 40°North-northeast) and 54° (Northeast) for wind trackers 1 and 2.

(3) CO

CO concentrations are described in Figure 6-21, showing that the CO trend of the maximum value is significantly different compared to the real CO value. However, the CO concentrations recorded were either 0 or 1 mg/m³ for both maximum and real values. The MR2 and MR3 (ambient) maximum values were used in the analysis due to the wind direction analysis.

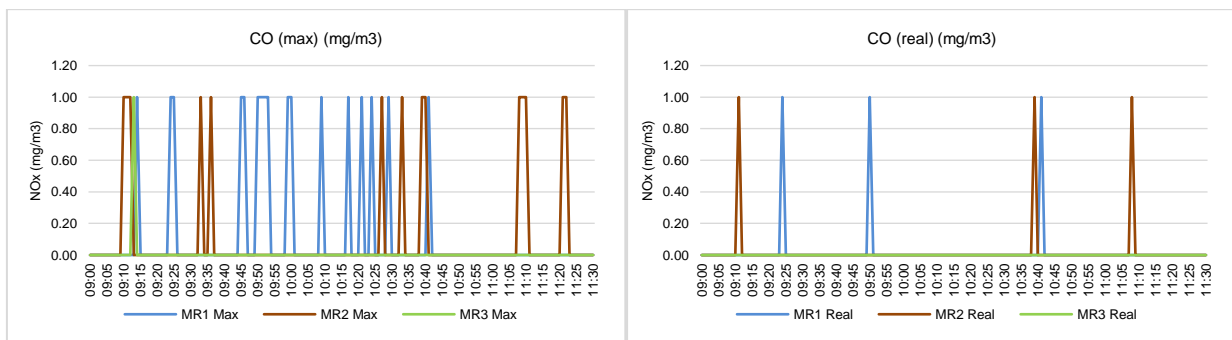

Figure 6-21: Measured CO concentrations at Bukit Batok Str. 52

(4) NO_x

As described in Figure 6-22, NO_x and CO were measured at three different locations: MR1 (East-West), MR2 (West-East) and MR3 (ambient). NO_x concentrations were recorded at maximum and real values, with a minute time interval. The maximum value represents the maximum value within a minute, whereas the real value counts the exact value at that minute. Overall, the real value is considered too low for such traffic flow (around 600 veh./hour in both directions). Therefore, the maximum value is taken for further analysis. The NO_x in the ambient environment (MR3) was recorded as stable at 0 mg/m³, whereas the concentration value at MR1 is neglected due to the wind direction. The NO_x value reached the peak at around 09.50 - 10.10 with a maximum value of 0.90 mg/m³.

Figure 6-22: Measured NO_x concentrations at Bukit Batok Str.52(5) PM_{2.5} and PM₁₀

As described in Figure 6-23, PM_{2.5} and PM₁₀ were measured at three different locations: OPC1 (East-West), OPC2 (West-East) and OPC3 (ambient). Automatic turn-off and manual start of the instrument during the period resulted in incomplete data for OPC2. Similar occurred at most other measurement locations due to equipment malfunction. Both PM concentrations indicate that the value recorded by OPC2 is significantly higher than OPC1 due to the wind direction. Unexpectedly, OPC1 showed a similar trend and value compared to OPC3 (ambient). Consequently, only OPC2 and OPC 3 values were used for further EF_s assessment. Still, these values were considered too low (unrealistic) for the analysis, as confirmed later in the next paragraph.

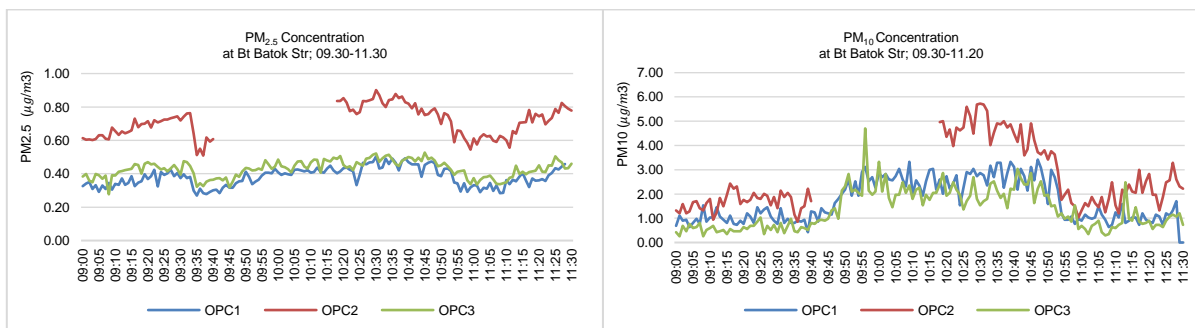
Figure 6-23: Measured PM_{2.5} and PM₁₀ concentrations at Bukit Batok Str.52

EFs are estimated using the methodology presented in Section 6.2.2, with the following results: CO = 1.86 – 2.30 g/veh.-km, NO_x = 3.24 – 3.60 g/veh.-km, PM_{2.5} = 5.21x10⁻⁶ – 7.95x10⁻⁶ g/veh.-km and PM₁₀ = 1.37x10⁻⁵ – 4.60x10⁻⁵ g/veh.-km. Only CO EF are considered within an acceptable range. NO_x EF tends to be overestimated by about a factor of 10, whereas PM_{2.5} and PM₁₀ the EFs value are too low (considered an unacceptable result, due to the malfunction of the equipment).

It is difficult to interpret the EF results because the sample time collected is limited, and it is too early to conclude that those EFs, which represent the selected road category, are within the acceptable range.

It is difficult to interpret the EF results because the sample time collected is limited, and it is too early to conclude that those EFs, which represent the selected road category, are within the acceptable range.

Table 6-12 summarises the determined aggregated EFs based on screened reliable data collected at two locations, with a total acceptable sampling of 7 out of 24 total measurement hours. Only EFs for CO and NO_x were estimated after considering the acceptable quality of data. It is difficult to interpret the EF results because the sample time collected is limited, and it is too early to conclude that those EFs, which represent the selected road category, are within the acceptable range.

Table 6-12: Determined EFs based on open road measurements

No.	Date	Time slot	Traffic flow (veh/h)	EFs CO (g/veh-km)	EFs NO _x (g/veh-km)
Expressway – AYE – Clementi Sports Hall (2 directions, 4 lanes each direction)					
1	Thu/ 09.02.17	08.00 – 09.00	7,231	20.30	7.14
		09.00 – 10.00	6,452	23.12	7.97
2	Thu/ 09.02.17	18.30 – 19.30	6,785	14.93	3.38
Min. art. Bt. Batok East Ave 5 (2 directions, 1 lane each direction)					
3	Wed/ 15.02.17	09.00 – 10.00	624	2.30	3.24
		10.00 – 11.00	786	1.86	3.60
4	Wed/ 15.02.17	15.00 – 16.00	682	1.70	n/a
		16.00 – 17.00	786	6.34	0.81
Total sampling hours		7			

More data measurements and analysis are needed to conclude this method is successful in estimating the real-world EFs. Only a few locations and collected data could be used due to data reliability. However, particular measurement concerns were revealed, such as (1) equipment differences as a highly qualified instrument is needed for outdoor purposes; (2) the wind direction changes quickly even at short distances (< 20 meters), making identification of potential upstream and downstream flows more difficult; (3) the location of ambient air quality measurement in a neutral location (without the intervention of pollutants from different sectors) should be considered carefully with a distance more than 10 km if possible.

6.2.5 Lessons learned

Open road measurements need carefully good quality portable equipment to ensure accurate EFs determination. Continuous air quality monitoring is needed due to quickly changing meteorological, traffic conditions and dispersion of air pollutants. More collected data can be gathered by continuous air quality monitoring. Consequently, more good quality data can be screened, clustered and analysed, which means more data samples. Previously limited research supports the findings for this method in worldwide applications. Determination of EFs

using continuous measurements at open roads should be conducted in cooperation with related government agencies using good air quality stations.

Air quality monitoring on open roads should be done over a long-term (continuous) period (minimum of three months) for more comprehensive traffic conditions, and concentration differences under upwind and downwind conditions. Better experiment preparation is needed for improved results such as getting a formal permit from related institutions to conduct field measurements, analysis of wind direction, better knowledge of equipment operation and early engagement of related institutions and government agencies.

Open road air quality monitoring studies conducted over a short period with portable equipment are more beneficial for estimating the pollutants concentrations to which commuters are exposed. For instance, particles exposure studies conducted by (Tan et al. 2017; Velasco and Tan 2016) at Orchard boulevard and the bus stop in Singapore (Tan et al. 2017) found that trip sections close to accelerating and idling vehicles such as bus stops, traffic junctions, and taxi stands represent hotspots of particles. Similarly, (Velasco and Tan 2016) indicated that the particle number concentrations at the bus stop were on average 3.5 times higher than the ambient concentrations.

The following points are suggestions for future open road measurements in determining the aggregated EFs:

- Air quality monitoring on open roads should be done over a long-term (continuous) period (minimum of three months) to get more comprehensive concentrations differences under upwind and downwind conditions.
- It is better to cooperate with the NEA for continuous measurement since NEA regularly monitors the ambient air quality for several pollutants (NO₂, CO, PM_{2.5}, PM₁₀, and SO₂) through a fully automated telemetric air quality monitoring and management system (TAQMMS). Three among sixteen stations are located at the roadside to assess the effectiveness of Singapore's vehicular emission control programmes. Moreover, dedicated stations to measure the ambient concentrations are also available.

6.3 Limitation

A critical point to consider is that tunnel studies serve only limited average fleets emissions under certain driving conditions. Limitations for this measurement are as follows;

- Getting permission to enter the tunnel was difficult due to several safety issues. During the measurement, it was not possible to check daily whether the equipment is fully functioning or not. Therefore, it is essential to prepare the equipment set in advance before entering the

tunnel. Otherwise, the low quality of data may arise. For this case, only CO and NO data were reliable;

- Reliable data was only 60% of the collected measurement data. Better air quality monitoring equipment could be prepared for the subsequent measurement;
- Limited driving conditions and speed: only limited for a typical urban tunnel expressway with a free-flow condition;
- Limited operating condition: only hot stabilised emissions;
- Vehicle distribution: the vehicle type captured by LTA's CCTV was not detailed enough, especially for HDVs. The share of HDVs was too low.
- Real grade and airflow data: the real tunnel grade and airflow data at that section need to be confirmed with LTA;
- More specific EFs: It was not possible to plot the EFs and LDV fraction into a regression model due to the low quality of vehicle distribution data.
- Overall, it was challenging to compare with other tunnel cases;

For open roadway measurements, equipment issues are; (1) the air quality monitoring equipment is mainly intended for indoor measurements; (2) The accuracy quality of each piece of equipment was different since collocation (calibration by manufacturer) time also different time (3) The storage capacity of each piece of equipment is different; therefore, long term measurement was not possible to conduct. (4) Several types of equipment have a different time set if the equipment is suddenly turned off and restarted.

6.4 Conclusion

The determination of EFs was performed in real-world conditions at the KPE tunnel and on selected open roads. The tunnel measurement quality was generally satisfying, and obtained results were acceptable, but some aspects should be improved. The aggregated EF results showed CO=1.46 g/veh-km and NO_x=0.28 g/veh-km. However, when comparing the results obtained from previous tunnel studies performed in different parts of the world (Section 6.1.4.4), it was evident that both EFs are in the low-level range.

The vehicle EFs are expected to change over time visibly due to some stringent transport environment policies, as confirmed by the case of Gubrist tunnel in Switzerland (Colberg et al. 2005; Staehelin et al. 1994). Therefore, it is essential to conduct these measurements at the same tunnel and section at recommended time intervals (10 years) to evaluate and assess vehicle technology improvements, fuel composition proportion development, the changes in fleet characteristics, and the effectiveness of inspection and maintenance programmes in a real-world setting.

Results from the open road experiment are premature to determine whether the EFs are within the acceptable range (Section 6.2.4). This is due to several limitations, particularly the equipment quality and application methods in the field. Still, lessons learned can be gathered for future experiments.

Both tunnel and open roads studies can be an excellent foundation for validating EFs from the emissions model and setting up a typical Singapore emissions model. Therefore, other tunnels or open road setting experiments need to be conducted further under various traffic situations (e.g. non-expressway, non-free-flow traffic). Besides, better air quality monitoring techniques and equipment and a traffic survey method are needed to obtain better air concentrations and traffic survey data.

Both measurements demonstrate the real-world Singapore EFs obtained with less cost and complexity (except for the related institutions' permission) compared to the dynamometer test method (Section 2.4.1). Still, combining both methods (real-world and under controlled conditions) in a local condition is the most suitable approach to obtain complete information on traffic emissions. Correct estimation of traffic emissions is also essential to predict mitigation scenarios (e.g. EVs), as will be discussed in Chapter 7.

7 Potential Emissions Reduction by Introduction of Electric Vehicles

In a highly populated urban area, the road transport sector is often the primary source of air quality problems and impacts CO₂ emissions globally. Still, this sector also offers the most significant opportunities for change. Several West European cities and other developed cities worldwide have been actively introducing essential technologies, such as electric vehicles (EVs) and renewable energy. However, the penetration rate of EVs and renewable energy is different in each country.

Singapore is keen on introducing EVs but not entirely renewable energy due to its constrained geographical area (Section 7.2.3). Factors affecting EVs implementation can be categorised into three dimensions: technology, policy, and environmental factors (Yong and Park 2017). This chapter focuses on EVs' environmental effects, and whether EVs offer great potential for air pollutants and CO₂ emissions reduction. This chapter also provides an overview of EVs status, explains existing policies, and summarises the results of the relevant air pollutants and CO₂ emissions impact of EVs' introduction under four scenarios in Singapore. Furthermore, recommendations for the most promising scenario to support future environmentally-friendly mobility are presented.

7.1 Introduction

Singapore's transport characteristics differ from other well-developed countries (as assessed in Chapters 4 and 5). The significant differences are (1) high-density urban population, (2) small size area as an island-city-country, (3) warm temperature and high humidity, (4) well-integrated urban, land use and transport planning, (5) and success in implementing sustainable urban transport policies. The above-mentioned significant differences in Singapore transport characteristics present considerable challenges in implementing EVs.

In Singapore, the current motor vehicle age is considerably younger (Section 4.4.3) than in other parts of the world due to comprehensive fiscal measures (Appendix A) in the transport sector. Therefore, a dedicated fleet model is required for an accurate and comprehensive analysis of vehicle stock flow for future fleet estimation and its influence on emissions. The forecasting of fleet development is based on Singapore's vehicle fleet historical statistics (2004-2019), as determined in Chapter 4.

EVs are considered the most promising alternative towards a cleaner transport sector, particularly in the road transport sector. As in this study, EVs are defined as full Battery EVs (BEVs), Hybrid EVs (HEVs) and Plug-in Hybrid EVs (PHEVs). HEVs and PHEVs include petrol

electrics and diesel electrics. They are often regarded as an essential means to reduce fossil fuels, CO₂ emissions and ameliorate air quality.

This chapter consists of several objectives: (1) Identify the current energy outlook, EVs, mobility and environment policies; (2) Outline EVs future mobility scenarios in reducing local air pollutants and CO₂ emissions; (3) Provide policy advice for decision-making and policy planning in the context of potential emissions reduction.

The scope of analysis covers:

- Potential emissions reduction impact without representing fuel cycle emissions nor including emissions from the electricity generation. This estimation is ordinarily consistent with national inventory reporting, where these emissions are captured elsewhere (e.g. under the power generation sector);
- Area: Singapore (only considering future registered vehicles in Singapore);
- The base year is 2019 ;
- The simulation period is 2025-2050 with five years sequence: 2025, 2030, 2035, 2040, 2045 and 2050;
- Assumptions:
 - EVs penetration in the field is integrated with other innovative mobility trends like ridesharing (such as Grab) and car-sharing. Their vehicle type classification is private hire vehicles (PHCs);
 - Priorities are set to BEVs as future potential EVs.
Over time, battery technology is expected to improve, resulting in a broader driving range and less charging time. At the same time, the price of the battery is decreasing.
- Charging station infrastructure, detailed battery type and economic incentives are not included in this analysis.

The study of future EVs using scenario research and modelling has been getting more attention recently. Objectives and focus of research vary, including implications or impact on electricity generation and grids and traffic safety. Several studies have investigated the impact of transport emissions reduction, but few looked at Singapore. In a GHGs lifecycle analysis for taxis in Singapore with an expected lifetime mileage of 1.1 million km, battery-electric taxis showed lower emissions than compressed natural gas (CNG) vehicles (Reuter et al. 2013). Moreover, another study by (Teoh et al. 2018) confirmed that selected BEV scenarios in freight transport lead to a potential reduction of CO₂ emissions by 23%-39%.

EVs penetration in Singapore offers several advantages from different perspectives. A restricted geographical area with a clear boundary of traffic activities within the island and the dense urban physical setting makes the establishment of charging infrastructures feasible. The existing infrastructures are highly developed, including the current power grid. Besides, travel activity is considered short for the average daily vehicle trip (30 – 50 km daily), except for taxis, buses,

and duty vehicles. The constant warm temperature condition (23°–31°Celsius) is suitable for battery performance and lifetime. Moreover, the primary energy source of electricity is natural gas which is considered cleaner energy. Also, a very effective regulatory environment in Singapore is complemented by a strong and stable government.

However, there are also some limitations related to specific conditions of Singapore. The city-state has a low CO₂ emissions profile (0.11% of global emissions) and less significant transport activities contributing to poor air quality. Because most electricity is generated from natural gas (not renewable sources), EVs are less environmentally friendly than they would be under other circumstances. Also, charging infrastructures are expanded but still limited.

Moreover, EVs are considered a less attractive business model for the private sector due to the lack of sizeable automobile industry and the limited size of the EVs market (as an impact of vehicle growth policy). The purchase cost of EVs is high with a limited lifetime due to COE and scrappage policies. With the higher cost of EVs, more incentives should be given to the environmentally-friendly mode. Future electricity demand would increase (energy-dependent on natural gas import). All those unique attributes may lead to different attitudes towards EVs in comparison with other countries.

7.2 The Singapore EVs, energy and policies outlook

As the main objective is to conduct a scenario analysis of the current state and future potential of EVs, a methodological procedure is applied by assessing the status of EVs development supported by existing policies that have been implemented for EVs penetration. This section also investigates energy outlook and related previous works that support the analysis in this research.

7.2.1 EVs in Singapore

Like other developed countries, EVs are seen in Singapore as the fundamental way to achieve cleaner transport. Initiatives to adopt EVs began in 2009 when LTA and EMA launched the EVs testbed program. The program aims to assess technical feasibility and establish the presence of EVs in Singapore. Since then, some progress has been made over a decade to support EVs' penetration, as summarised in Table 7-1. Furthermore, in February 2020, the government declared a great ambition to phase out the ICE vehicles by 2040 for public health and climate change reasons. To achieve the goal, more attractive policies on EVs are expected from 2021.

Table 7-1: Singapore's policies that support the penetration of EVs (summarised from literature (APEC 2017; LTA 2010))

1	2001, 2013	Promotion policy purchasing support and tax policy	The Green Vehicle Rebate (GVR) programme provide an offset on the registration fees for green vehicles. In 2013, the GVR programme was upgraded to include a rebate
2	2010	Promotion policy purchasing support	Singapore launched an initiative in June 2010 to invest \$20 million in the establishment of a comprehensive network of recharging stations and to provide incentives for the purchase of EVs. The local government's main objective is to attract the electric vehicle industry to Singapore.
3	2010	Research and Development support (R&D)	Joint research cooperation between NTU and TUM was established under TUM CREATE, focusing on electromobility.
4	2011	Promotion policy – institutional	LTA founded the Electric Vehicle Task Force (EVTP) to promote the introduction of EVs and the development of charging technology.
5	2011	R&D	The introduction of Singapore's electric car testbed is announced.
6	2012	Promotion policy purchasing support	The Fuel Economy Labelling system (FELS) is introduced.
7	2013	Tax policy	Carbon Emissions-Based Vehicle Schema (CEVS) is introduced.
8	2013	R&D	NTU has carried out initial tests with a driverless vehicle in Singapore. The EV named NAVIA had eight passengers and served the routes between NTU and the industrial park, with a driving speed of 20km/h.
9	2014	Promotion policy- a master plan	Car-lite Singapore was introduced as part of Sustainable Blueprint 2015 and Clean & Green Transport to support the use of public transport and car-sharing to reduce emissions.
10	2014	Promotion policy	Plans to trial an EV car-sharing programme that will introduce up to 1,000 EVs and the charging infrastructure to support their use are announced.
11	2016	Promotion policy	Approximately 2,000 charging stations will be installed on the island as part of an electric vehicle car-sharing programme.
12	2017	Promotion policy Commercial fleet users	BlueSG Pte Ltd, a Bolloré Group subsidiary, signed an agreement with the NTU and Economic Development Board (EDB) to operate BlueSG, an economy-wide car-sharing programme.
13	2018	Trial-implementation	Conducting trials with 50 diesel HEV buses since December 2018.
14	2019	Land Transport Master Plan (LTMP) 2019 up to 2040 Policy target	Commitment to having <ul style="list-style-type: none"> • 100% cleaner energy public bus fleet by 2040, such as electric or HEVs; • 100% cleaner energy taxi vehicles by 2040, such as HEVs, electric or a mixture of both; • Some private hire car booking providers and car rental companies to make their entire fleet run on cleaner energy by 2040.
15	2020	Private sector commitment	The taxi companies have gone even further by committing to having 90% of their fleet run on cleaner energy by 2025.
16	2021	Tax policy	Revision of road tax to support EV owners New EV purchases will receive rebates for three years from January 2021.

Recent years have seen a rapid growth of EVs and smart cities' popularity, including in Singapore. The growth of EVs for passenger cars (including PHCs) and taxis is available in Figure 7-1 and Figure 7-2. Significant growth is evident in the development share of HEVs, mainly for taxis. Unfortunately, the penetration of BEVs remains very slow and limited until recently due to certain limitations such as long charging time, installation of charging infrastructure, and higher upfront cost. However, BEVs' penetration is expected to progress rapidly in the future, together with technology and energy improvement.

7.2.2 Number of electric cars in Singapore

In 2019, the share of electric cars in Singapore remained small, around 8% of total cars (PCs, PHCs and taxis) or 54,715 vehicles. The slow development of EVs is observed from 2004-2014, starting to gain popularity in 2014, especially for hybrid-petrol and petrol-PHEV types. The amount of BEVs is still too low. It started with 1 to 12 BEVs in 2014-2016, increasing rapidly to 1,253 BEVs in 2019.

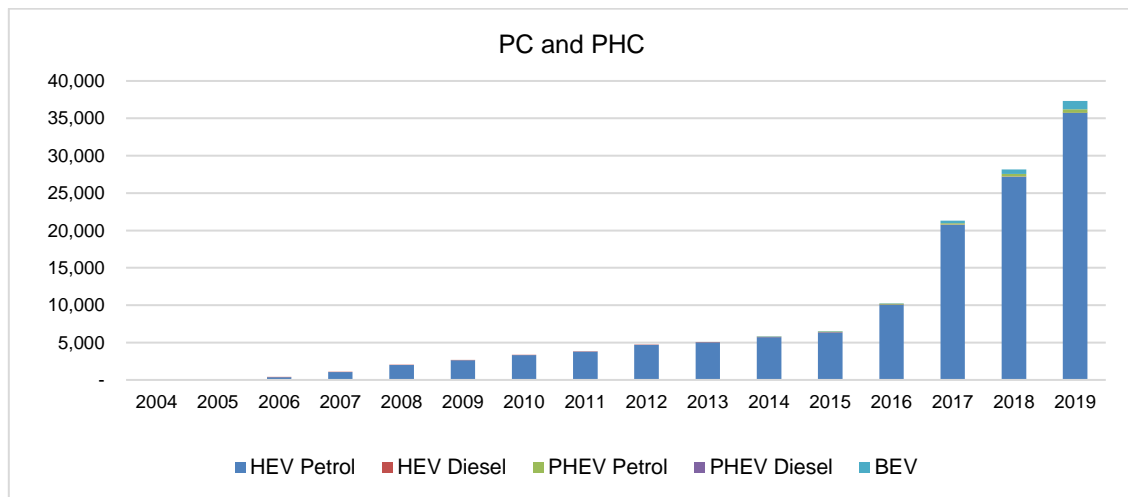

Figure 7-1: Electric PCs and PHCs development in Singapore

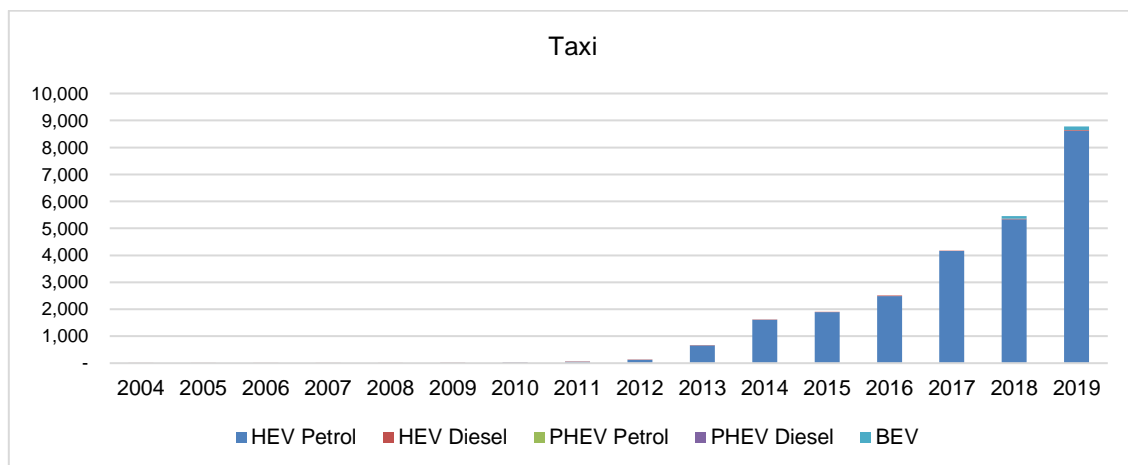

Figure 7-2: Electric taxis development in Singapore

7.2.3 Singapore's energy outlook, transport outlook and related policies

Emissions from EVs greatly vary depending on the electricity mix used in a country. Over time, Singapore's electricity generation industry moved away from petroleum products (mainly diesel and fuel oil) to the better environmental option of natural gas, as shown in Figure 7-3. Natural gas (around 95%) is a crucial energy generator in Singapore. However, the natural gas supply relies upon four offshore pipelines connected to Malaysia and Indonesia.

Due to Singapore’s limited geographical area, renewable energy options are limited. According to Singapore EMA, there are no hydro resources, wind speeds and mean tidal range are low, and geothermal energy is economically not viable (Energy Market Authority 2017a). Solar energy remains the most feasible renewable energy option due to its location in the tropical sunbelt. Singapore is exploring ways to increase the use of solar energy.

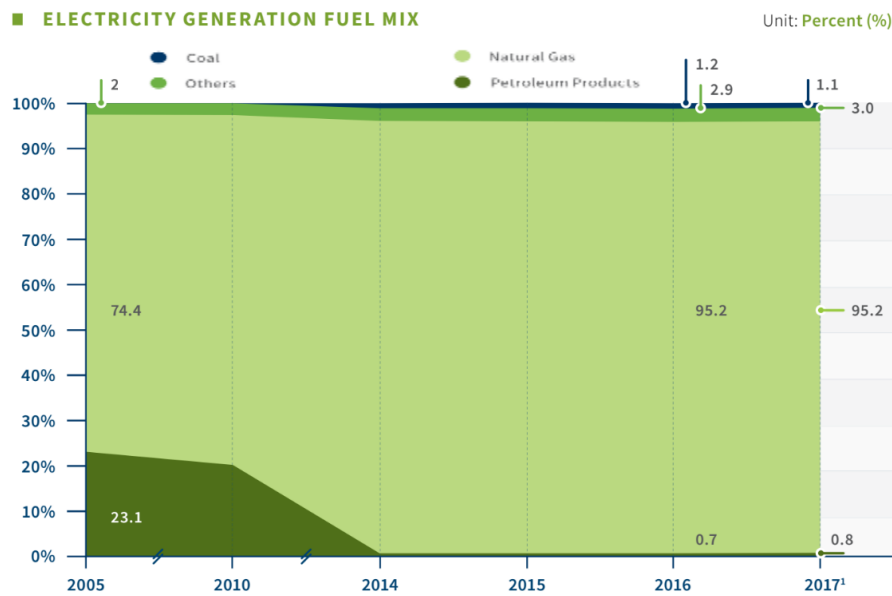

Figure 7-3: Limited electricity generation in Singapore (Energy Market Authority 2017a)

According to EMA, Singapore’s Grid Emission Factor (GEF), which measures emissions per unit of electricity generated, remained relatively consistent at 0.4085 kg CO₂ /kWh in 2019 (Energy Market Authority 2017b).

Singapore has committed to sustainable development addressing urban issues of congestion and pollution, among others. To ensure sustainable development, the government controls its vehicle population tightly by setting an annual growth rate and bidding for the right to own and use a vehicle for a limited number of years (see annual growth rate in Section 4.3).

7.3 Framework development

The EVs scenario is developed using the vehicle fleet model; a similar procedure was done for vehicle projection as described in Chapter 4 to assess the impact of electrification on air pollutants and CO₂ emissions. Moreover, the emissions calculation of combustion engine vehicles, HEVs and PHEVs vehicles is based on COPERT, a road transport emissions inventory software the same as the one addressed in Chapter 5. CO₂ emissions and exhaust air pollutants have been set to zero emissions, or emissions are compensated in the energy sector for BEVs type.

7.3.1 Background fleet and emission information

Due to unique transport characteristics in Singapore, a dedicated vehicle fleet model with a comprehensive analysis of the vehicle stock flow and its distribution has been developed (Chapter 4), addressing motor vehicles and their activities on emissions (Chapter 5). The historical information on Singapore vehicle fleet development from 2004-2019 is used as a starting point for future fleet model development.

7.3.2 Scenario, variables and responses

Due to several uncertainties in Singapore's policy and its target beyond 2020, four scenarios are designed to assess how EVs can impact air pollutants and CO₂ emissions. The scenarios cover business as usual (BaU), low, medium, and high electrification with the reference year of 2019.

- BaU assumes that future development trends follow those in the past (2004-2019) without changing policy directions. This scenario is used as the only emissions trajectory reference, making it possible to assess air pollutants' reduction potential and CO₂ emissions under scenarios.
- Scenario 1: Low (L) scenario considers substantially lower electrification considering the essential recently implemented or planned policies
- Scenario 2: Medium (M) scenario suggests medium-scale electrification under particular conditions.
- Scenario 3: High (H) scenario proposes the most ambitious scenario applying high penetration EVs rate and specific policy support ranges as assumptions.

The scenario is predicted until 2050, with a sequence of five-year scenario projection estimations starting from 2025, 2030, 2035, 2040, 2045, and up to 2050. Each scenario distinguishes between the existing vehicle types: PCs, PHCs, taxis, LCVs, HDVs, public buses, coaches, and MCs. The following dynamic performance data were defined for each vehicle type for annual growth rate and the different adoption rates of EVs (HEVs, PHEVs, and BEVs) per vehicle type. While for annual VKT, the same projections are valid for all scenarios. The main assumptions for the four scenarios are discussed in the next section.

BaU

The BaU scenario is aimed to offer the most realistic outlook of EV developments. It is based on state-of-the-art evidence gathered in the previous chapter (Chapters 4 and 5). The critical assumptions of the scenario are explained as follows:

- EVs incentives from the government are assumed to continue in the current situation.

- Most consumers still hesitate to shift to EVs as the total vehicle ownership is higher and charging stations are limited.
- Vehicle lifetime is the same as the current situation.
- Energy prices (diesel, petrol, and electricity) are assumed the same as today.
- The annual growth rate is assumed based on historical trend
- The government has announced a significant vehicle growth rate since 1990 (Section 4.3). However, according to the historical statistical data analysis, the real growth rate is higher than that stipulated. Therefore, each vehicle type’s future annual growth rate is based on historical average annual growth rate in 2004-2019; PCs (2.1%), taxis (-0.4%), LDVs (0.5%), HDVs (1.4%), public buses (3.3%), coaches (2.5%), and MCs (0.2%). An exception is given to PHCs (18.4%), where the average growth is considered too high for Singapore's limited area; therefore, 5% growth is taken as a reliable assumption.

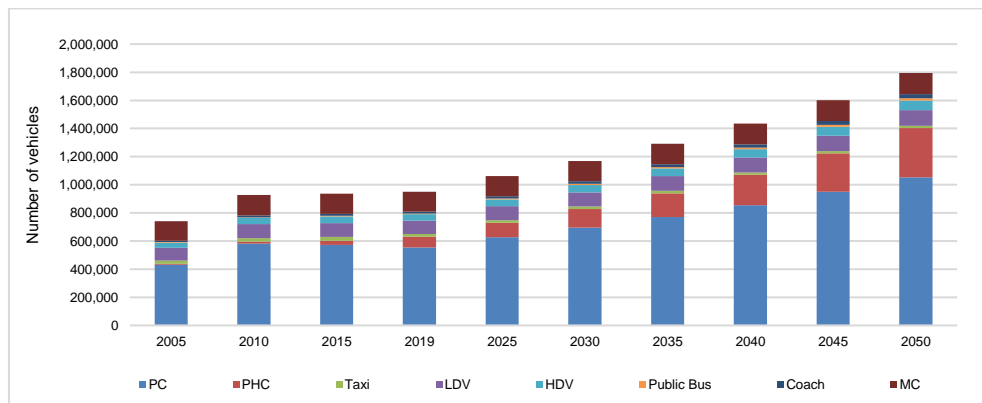

Figure 7-4: Historical and projected vehicle population - BaU scenario

- Average VKT
VKT of each vehicle type is also based on the historical trendline from 2004-2019, as shown in Figure 7-5.

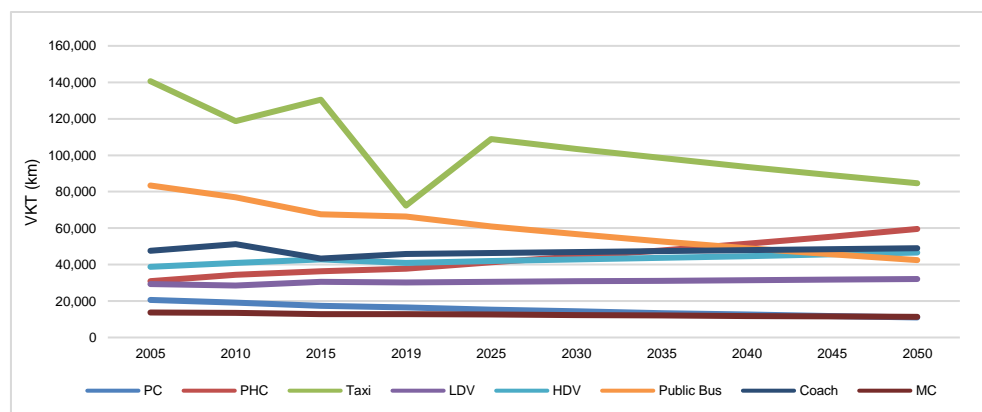

Figure 7-5: Historical and projected VKT – BaU scenario

- Penetration of EVs is determined differently in each vehicle type, except for PHCs and PCs. The following figure describes the penetration rate of PCs and PHCs. Detailed penetration

of EVs per vehicle is described below. In 2045, HEVs' share is predicted to decrease as significant technology improvement is expected for PHEVs and BEVs.

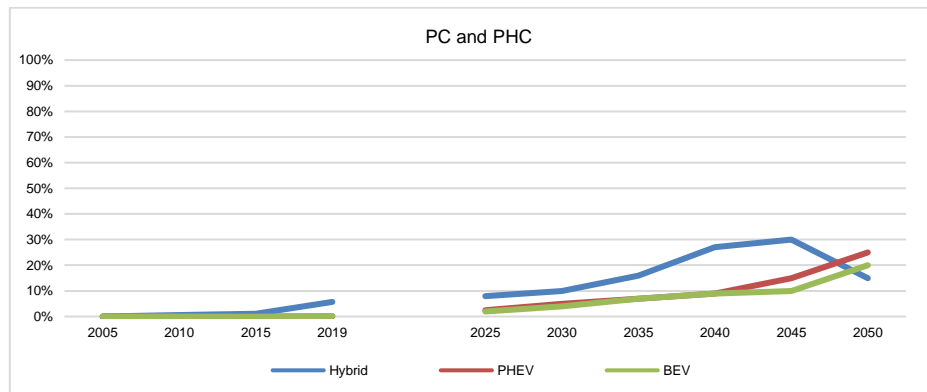

Figure 7-6: Historical and projected EVs share of PC and PHC – BaU scenario

Table 7-2: Historical and projected EVs share in BaU scenario

Vehicle type	EV type	2005	2010	2015	2019	2025	2030	2035	2040	2045	2050
PC = PHC	HEV	0.0%	0.6%	1.1%	5.7%	8.0%	10.0%	16.0%	27.0%	30.0%	15.0%
	PHEV	0.0%	0.0%	0.0%	0.1%	2.5%	5.0%	7.0%	9.0%	15.0%	25.0%
	BEV	0.0%	0.0%	0.0%	0.2%	2.0%	4.0%	7.0%	9.0%	10.0%	20.0%
	Total	0.0%	0.6%	1.1%	5.9%	12.5%	19.0%	30.0%	45.0%	55.0%	60.0%
Taxi	HEV	0.0%	0.0%	5.6%	46.5%	50.0%	55.0%	47.0%	40.0%	35.0%	30.0%
	PHEV	0.0%	0.0%	0.0%	0.0%	3.0%	4.0%	10.0%	11.0%	15.0%	10.0%
	BEV	0.0%	0.0%	0.0%	0.7%	2.0%	3.0%	8.0%	14.0%	20.0%	30.0%
	Total	0.0%	0.0%	5.6%	47.2%	55.0%	62.0%	65.0%	65.0%	70.0%	70.0%
MC	BEV	0.0%	0.0%	0.0%	0.0%	5.0%	15.0%	25.0%	35.0%	45.0%	55.0%
	Total	0.0%	0.0%	0.0%	0.0%	5.0%	15.0%	25.0%	35.0%	45.0%	55.0%
LCV	HEV	0.0%	0.0%	0.0%	0.0%	3.6%	5.5%	7.7%	12.0%	18.0%	20.0%
	BEV	0.0%	0.0%	0.0%	0.1%	0.5%	3.0%	5.0%	8.0%	11.0%	15.0%
	Total	0.0%	0.0%	0.0%	0.1%	4.1%	8.5%	12.7%	20.0%	29.0%	35.0%
HDV	HEV	0.0%	0.0%	0.0%	0.0%	0.4%	0.8%	1.5%	5.0%	8.5%	13.0%
	BEV	0.0%	0.0%	0.0%	0.1%	0.1%	0.2%	0.5%	2.0%	4.5%	7.0%
	Total	0.0%	0.0%	0.0%	0.1%	0.5%	1.0%	2.0%	7.0%	13.0%	20.0%
Urban Bus	HEV	0.0%	0.1%	0.1%	0.9%	4.0%	6.0%	9.0%	10.0%	15.0%	19.0%
	BEV	0.0%	0.0%	0.0%	0.2%	1.0%	3.0%	5.0%	9.0%	10.0%	15.0%
	Total	0.0%	0.1%	0.1%	1.1%	5.0%	9.0%	14.0%	19.0%	25.0%	34.0%
Coach	HEV	0.0%	0.0%	0.0%	0.0%	1.0%	3.0%	8.0%	12.0%	14.0%	17.0%
	BEV	0.0%	0.0%	0.0%	0.0%	0.0%	2.0%	5.0%	6.0%	9.0%	11.0%
	Total	0.0%	0.0%	0.0%	0.0%	1.0%	5.0%	13.0%	18.0%	23.0%	28.0%

Scenario 1

Scenario 1 is based on the following considerations:

- Annual average vehicle growth development is based on a trend line of historical data (only for PCs, LDVs, HDVs, public buses and MCs). For other vehicle types, an adjustment of the annual growth rate is used for the projection to avoid the overprediction of the vehicles.
- VKT projection is similar to the BaU (Figure 7-5).
- EVs' incentives from the government are assumed to increase slightly compared to the current situation.
- The charging infrastructure of EVs increases slowly over time.

Table 7-3: Growth rate projection in BaU scenario

PC	63,184*LN(n) + 419851
PHC	2%
Taxi	-0.40%
LDV	92059*(n) ^{0.0248}
HDV	4,082.6*LN(n) + 36201
Public bus	3,275.2*EXP(0.0359*n)
Coach	2%

Table 7-4: Historical and projected EVs share in S1 scenario

Vehicle type	EV type	2005	2010	2015	2019	2025	2030	2035	2040	2045	2050
PC = PHC	HEV	0.0%	0.6%	1.1%	5.7%	11.5%	17.5%	26.0%	21.0%	18.0%	10.0%
	PHEV	0.0%	0.0%	0.0%	0.1%	5.0%	8.0%	11.0%	14.0%	17.0%	20.0%
	BEV	0.0%	0.0%	0.0%	0.2%	2.0%	4.0%	8.0%	15.0%	25.0%	40.0%
	Total	0.0%	0.6%	1.1%	5.9%	18.5%	29.5%	45.0%	50.0%	60.0%	70.0%
Taxi	HEV	0.0%	0.0%	5.6%	46.5%	52.0%	55.0%	50.0%	40.0%	23.0%	10.0%
	PHEV	0.0%	0.0%	0.0%	0.0%	5.0%	8.0%	13.0%	17.0%	27.0%	15.0%
	BEV	0.0%	0.0%	0.0%	0.7%	3.0%	5.0%	10.0%	18.0%	30.0%	55.0%
	Total	0.0%	0.0%	5.6%	47.2%	60.0%	68.0%	73.0%	75.0%	80.0%	80.0%
MC	BEV	0.0%	0.0%	0.0%	0.0%	7.0%	13.0%	20.0%	40.0%	60.0%	75.0%
	Total	0.0%	0.0%	0.0%	0.0%	7.0%	13.0%	20.0%	40.0%	60.0%	75.0%
LCV	HEV	0.0%	0.0%	0.0%	0.0%	4.0%	7.5%	12.0%	17.0%	25.0%	25.0%
	BEV	0.0%	0.0%	0.0%	0.1%	1.0%	3.5%	8.0%	13.0%	20.0%	30.0%
	Total	0.0%	0.0%	0.0%	0.1%	5.0%	11.0%	20.0%	30.0%	45.0%	55.0%
HDV	HEV	0.0%	0.0%	0.0%	0.0%	2.5%	6.0%	11.0%	19.0%	25.0%	32.0%
	BEV	0.0%	0.0%	0.0%	0.1%	0.5%	2.0%	5.0%	6.0%	12.0%	15.0%
	Total	0.0%	0.0%	0.0%	0.1%	3.0%	8.0%	16.0%	25.0%	37.0%	47.0%
Urban Bus	HEV	0.0%	0.1%	0.1%	0.9%	7.0%	11.0%	15.0%	20.0%	15.0%	12.0%
	BEV	0.0%	0.0%	0.0%	0.2%	3.0%	4.0%	5.0%	10.0%	25.0%	38.0%
	Total	0.0%	0.1%	0.1%	1.1%	10.0%	15.0%	20.0%	30.0%	40.0%	50.0%
Coach	HEV	0.0%	0.0%	0.0%	0.0%	3.0%	6.0%	9.0%	13.0%	17.0%	18.0%
	BEV	0.0%	0.0%	0.0%	0.0%	2.0%	3.0%	6.0%	9.0%	13.0%	19.0%
	Total	0.0%	0.0%	0.0%	0.0%	5.0%	9.0%	15.0%	22.0%	30.0%	37.0%

Scenario 2

- Annual average growth rate vehicle is based on the selected annual growth rate: PCs (0%), PHCs (1%), taxis (-0.4%), LDVs (0.25%), HDVs (1%), public buses (2%), coaches (1,5%) and MCs (0%).
- VKT projection is similar to the BaU.
- EVs incentives from the government are assumed to increase gradually compared to the current situation.
- The charging infrastructure increases gradually.
- HEVs are more favourable in this scenario.
- The consumer is getting more familiar with EVs and may think to replace the old ICE with EVs.

Table 7-5: Historical and projected EVs share in S2 scenario

Vehicle type	EV type	2005	2010	2015	2019	2025	2030	2035	2040	2045	2050
PC = PHC	HEV	0.0%	0.6%	1.1%	5.7%	13.0%	15.0%	10.0%	10.0%	7.0%	5.0%
	PHEV	0.0%	0.0%	0.0%	0.1%	6.0%	10.0%	15.0%	20.0%	18.0%	15.0%
	BEV	0.0%	0.0%	0.0%	0.2%	4.0%	10.0%	25.0%	40.0%	55.0%	70.0%
	Total	0.0%	0.6%	1.1%	5.9%	23.0%	35.0%	50.0%	70.0%	80.0%	90.0%
Taxi	HEV	0.0%	0.0%	5.6%	46.5%	55.0%	50.0%	30.0%	20.0%	15.0%	10.0%
	PHEV	0.0%	0.0%	0.0%	0.0%	8.0%	10.0%	20.0%	25.0%	25.0%	20.0%
	BEV	0.0%	0.0%	0.0%	0.7%	4.0%	8.0%	20.0%	30.0%	43.0%	60.0%
	Total	0.0%	0.0%	5.6%	47.2%	67.0%	68.0%	70.0%	75.0%	83.0%	90.0%
MC	BEV	0.0%	0.0%	0.0%	0.0%	10.0%	17.0%	25.0%	55.0%	75.0%	90.0%
	Total	0.0%	0.0%	0.0%	0.0%	10.0%	17.0%	25.0%	55.0%	75.0%	90.0%
LCV	HEV	0.0%	0.0%	0.0%	0.0%	6.0%	13.0%	20.0%	31.0%	30.0%	30.0%
	BEV	0.0%	0.0%	0.0%	0.1%	3.0%	5.0%	10.0%	18.0%	30.0%	50.0%
	Total	0.0%	0.0%	0.0%	0.1%	9.0%	18.0%	30.0%	49.0%	60.0%	80.0%
HDV	HEV	0.0%	0.0%	0.0%	0.0%	3.5%	8.0%	13.0%	20.0%	27.0%	35.0%
	BEV	0.0%	0.0%	0.0%	0.1%	1.5%	4.0%	7.0%	12.0%	20.0%	25.0%
	Total	0.0%	0.0%	0.0%	0.1%	5.0%	12.0%	20.0%	32.0%	47.0%	60.0%
Urban Bus	HEV	0.0%	0.1%	0.1%	0.9%	7.0%	15.0%	25.0%	25.0%	30.0%	30.0%
	BEV	0.0%	0.0%	0.0%	0.2%	3.0%	10.0%	15.0%	25.0%	45.0%	60.0%
	Total	0.0%	0.1%	0.1%	1.1%	10.0%	25.0%	40.0%	50.0%	75.0%	90.0%
Coach	HEV	0.0%	0.0%	0.0%	0.0%	5.0%	9.0%	15.0%	20.0%	27.0%	31.0%
	BEV	0.0%	0.0%	0.0%	0.0%	2.0%	6.0%	12.0%	20.0%	25.0%	37.0%
	Total	0.0%	0.0%	0.0%	0.0%	7.0%	15.0%	27.0%	40.0%	52.0%	68.0%

Scenario 3

The critical assumption of the ambitious scenario is explained below:

- The vehicle population growth is tempered, considering the constraints of a small country. The annual average vehicle growth rate tends to have a negative growth rate for several vehicle types. An annual growth rate of -1% in PCs, -1% in taxis, 0% in MCs, 0% in HDVs, 0.25% in LDVs and 1% in the coach was assumed; a shift mode is expected to support the environmental mode of transport. At the same time, a 2% growth rate is adopted for public buses. A declining total vehicle trend is expected in the future, as described in Figure 7-7. Around 842,000 vehicles are projected in 2050, with a reduction of 11% from 2019.

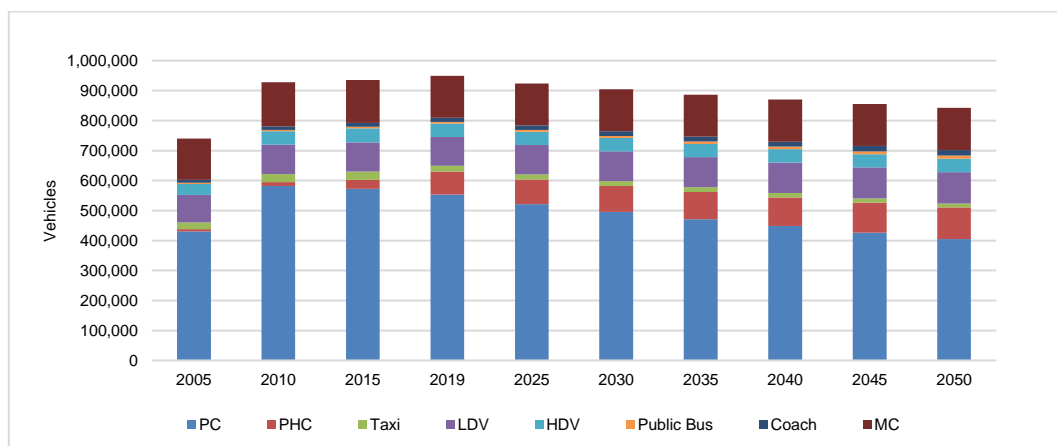

Figure 7-7: Historical and projected vehicles population - Scenario 3

- VKT projection is similar to the BaU.

- The government considers whether to bring forward a proposed ban on the sale of new petrol, diesel, and HEVs cars from 2035 to 2050. Increased emission tax for ICE vehicles is also an additional option.
- The government is keen on zero-emission on the road by 2040 for PCs, MCs, and public buses, and 2050 for the rest of the vehicle types (at least HEVs). The public buses become cleaner and driverless.
- EVs incentives from the government are assumed to increase dramatically compared to the current situation.
 - o Provide more tax rebates for new EVs.
 - o Change of vehicle age lifetime for specific EVs.
- Performance of EVs (from a global perspective):
 - o More EVs vehicle types are available; the EVs price is getting lower globally.
 - o The after-sale of EVs is likely managed.
- Charging:
 - o More charging points and infrastructure are available.
 - o Ultra-fast charging dispels road anxiety.

Table 7-6: Historical and projected EV share in S3 scenario

Vehicle type	EV type	2005	2010	2015	2019	2025	2030	2035	2040	2045	2050
PC = PHC	HEV	0.0%	0.6%	1.1%	5.7%	12.0%	21.0%	35.0%	30.0%	13.0%	0.0%
	PHEV	0.0%	0.0%	0.0%	0.1%	6.0%	12.0%	17.0%	20.0%	7.0%	0.0%
	BEV	0.0%	0.0%	0.0%	0.2%	6.0%	12.0%	23.0%	50.0%	80.0%	100.0%
	Total	0.0%	0.6%	1.1%	5.9%	24.0%	45.0%	75.0%	100.0%	100.0%	100.0%
Taxi	HEV	0.0%	0.0%	5.6%	46.5%	55.0%	30.0%	10.0%	0.0%	0.0%	0.0%
	PHEV	0.0%	0.0%	0.0%	0.0%	8.0%	25.0%	20.0%	0.0%	0.0%	0.0%
	BEV	0.0%	0.0%	0.0%	0.7%	7.0%	25.0%	60.0%	100.0%	100.0%	100.0%
	Total	0.0%	0.0%	5.6%	47.2%	70.0%	80.0%	90.0%	100.0%	100.0%	100.0%
MC	BEV	0.0%	0.0%	0.0%	0.0%	15.0%	30.0%	60.0%	100.0%	100.0%	100.0%
	Total	0.0%	0.0%	0.0%	0.0%	15.0%	30.0%	60.0%	100.0%	100.0%	100.0%
LCV	HEV	0.0%	0.0%	0.0%	0.0%	13.0%	30.0%	50.0%	40.0%	20.0%	0.0%
	BEV	0.0%	0.0%	0.0%	0.1%	7.0%	20.0%	40.0%	60.0%	80.0%	100.0%
	Total	0.0%	0.0%	0.0%	0.1%	20.0%	50.0%	90.0%	100.0%	100.0%	100.0%
HDV	HEV	0.0%	0.0%	0.0%	0.0%	4.0%	9.0%	16.0%	25.0%	33.0%	40.0%
	BEV	0.0%	0.0%	0.0%	0.1%	2.0%	5.0%	9.0%	15.0%	27.0%	40.0%
	Total	0.0%	0.0%	0.0%	0.1%	6.0%	14.0%	25.0%	40.0%	60.0%	80.0%
Urban Bus	HEV	0.0%	0.1%	0.1%	0.9%	10.0%	28.0%	35.0%	35.0%	20.0%	0.0%
	BEV	0.0%	0.0%	0.0%	0.2%	5.0%	12.0%	25.0%	50.0%	75.0%	100.0%
	Total	0.0%	0.1%	0.1%	1.1%	15.0%	40.0%	60.0%	85.0%	95.0%	100.0%
Coach	HEV	0.0%	0.0%	0.0%	0.0%	6.0%	12.0%	20.0%	23.0%	30.0%	35.0%
	BEV	0.0%	0.0%	0.0%	0.0%	4.0%	8.0%	15.0%	27.0%	40.0%	55.0%
	Total	0.0%	0.0%	0.0%	0.0%	10.0%	20.0%	35.0%	50.0%	70.0%	90.0%

7.3.3 Intermediate result of the vehicle fleet

Vehicle growth

The following figure describes the projection of total vehicles in four scenarios. Vehicle growth control has been successfully implemented in Singapore due to the limited space available. For this reason, this measure is chosen as part of emissions reduction potential parameters. Besides, in terms of implementation, this measure can be continuous or become even more

stringent. Also, controlling a VKT is more complicated than vehicle growth control, as travel activities mostly rely on individual or corporate decisions.

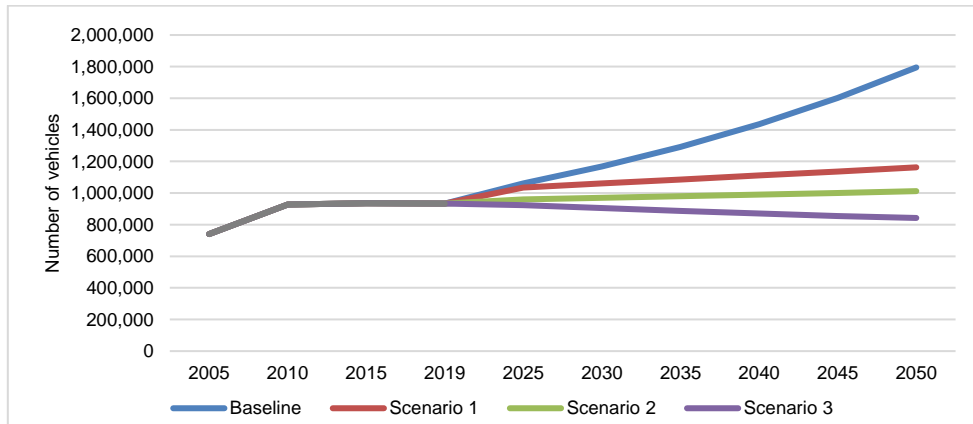

Figure 7-8: Projection of vehicles under different scenarios

Figure 7-9 describes the trend of vehicle projection based on eight vehicle type categorisations. A clear trend is shown in the PCs, due to the highest share of vehicles. PCs are projected to have a significant rise in BaU, a slow increase in S1, a steady trend in S2 and a moderately slow trend in S3. PHCs are predicted to have a considerable rise in BaU, a moderate increase in S1 and a slow growth in S2 and S3.

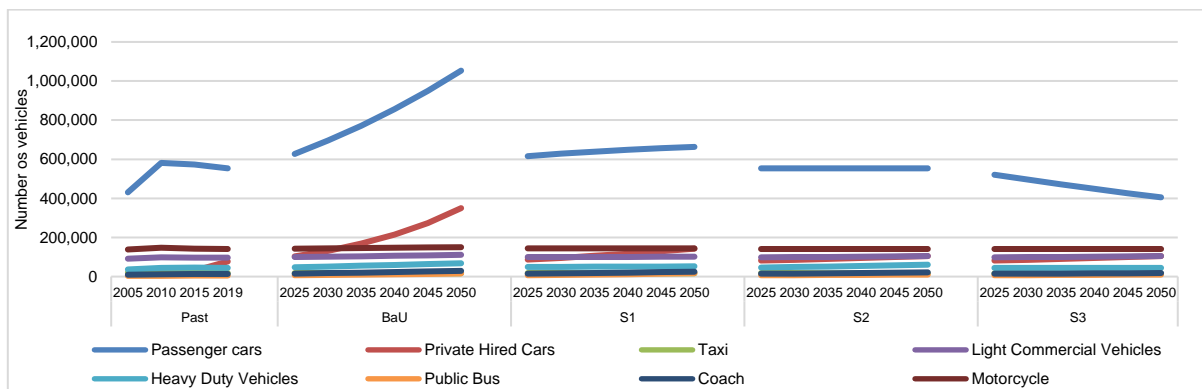

Figure 7-9: Vehicles number in the past and projection in four scenarios

EVs penetration trajectory

An overview of EV penetration per vehicle type in a different scenario can be seen in Figures 7-9-7-15. In the PC and PHC vehicle categories, ICE is targeted to phase out on Singapore’s roads in S3 by 2040. In S2, 90% of PCs and PHCs are planned as EVs by 2040, whereas in S1 and BaU around 35% and 45% of vehicles are predicted still use ICE.

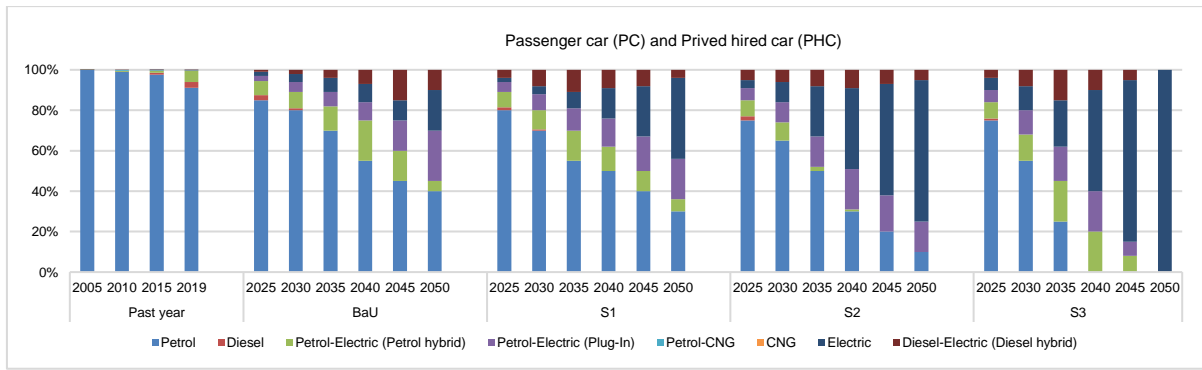

Figure 7-10: PC and PHC share in past years and the scenarios

For MCs, only full BEVs are available for this segment. In 2040, BEVs are targeted as 100% by S3.

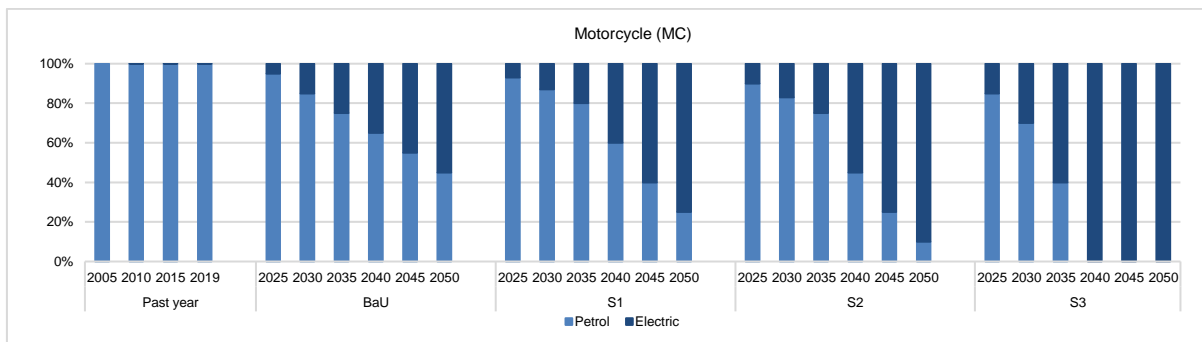

Figure 7-11: MC share in past years and scenarios

Similar to MCs, PCs and PHCs, taxis are targeted to be 100% operated by BEVs in 2040 using S3, whereas S2 plans 90% of EVs in 2050. Diesel taxis are estimated to remain in 2050 under BaU and S1 scenarios with a share of around 35% and 20%.

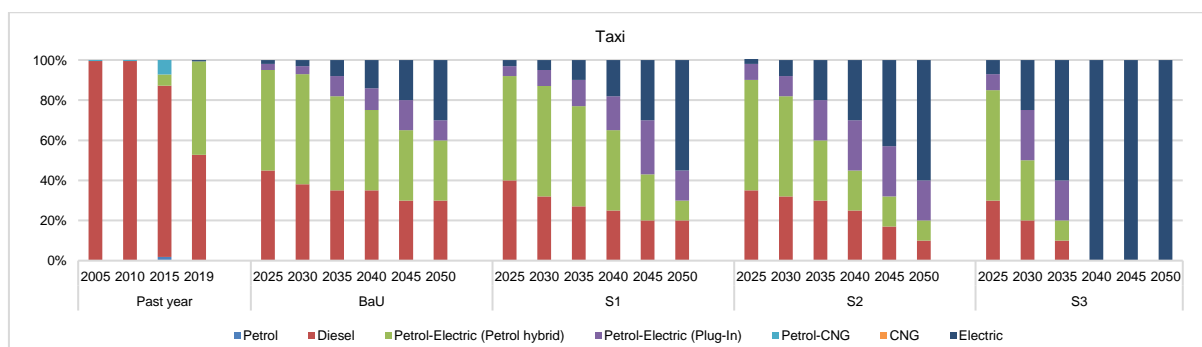

Figure 7-12: Taxi share in past years and the scenarios

Public buses with high travel activity have a substantial potential to reduce air pollution if replaced by EVs. However, electric public buses' current development is not as advanced as PC and MC segments' developments. Therefore, EV penetration is introduced slowly in public buses (BaU and S1), but sure to reach 90% and 100% EV in 2050 using S2 and S3.

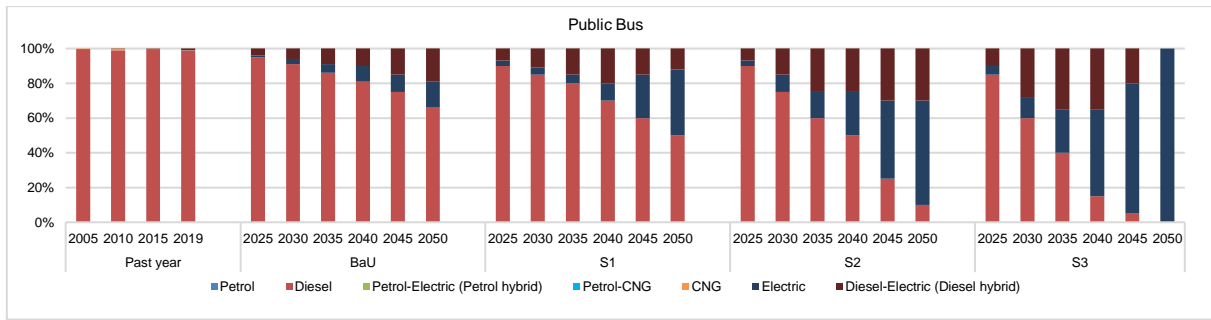

Figure 7-13: Public bus share in past years and the scenarios

A similar EV penetration for public buses trend is also valid for coaches. However, EV penetration in all scenarios is slightly behind public buses because many private sectors are involved in this segment, and compared to public buses, a governmental subsidy is typically not expected in this sector.

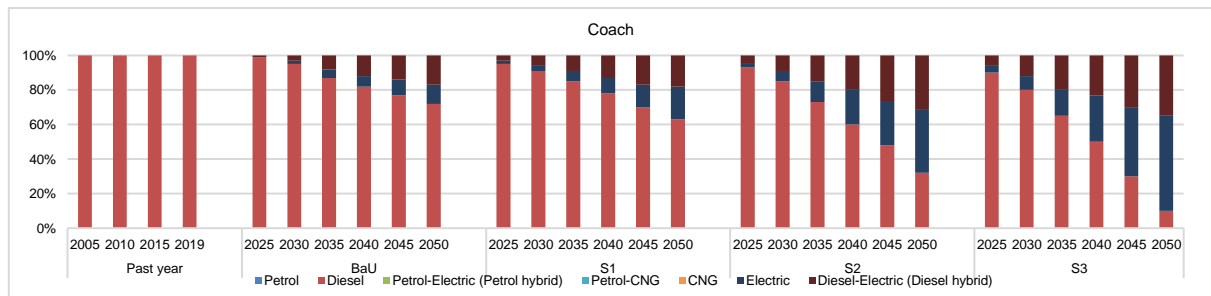

Figure 7-14: Coaches share in past years and the scenarios

Private sectors usually operate LDVs and HDVs. The penetration of projected EVs is faster in LDVs than HDVs since the technology is expected to advance faster in a smaller vehicle type. Besides, the turnover age of HDVs tends to be longer compared to LDVs. The projection of EV penetration in LDVs and HDVs is illustrated in Figure 7-15 and Figure 7-16.

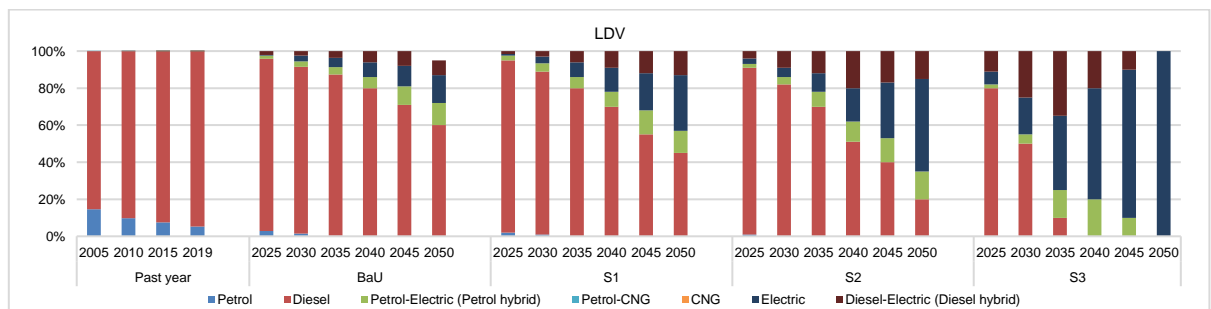

Figure 7-15: LDV share in past years and the scenarios

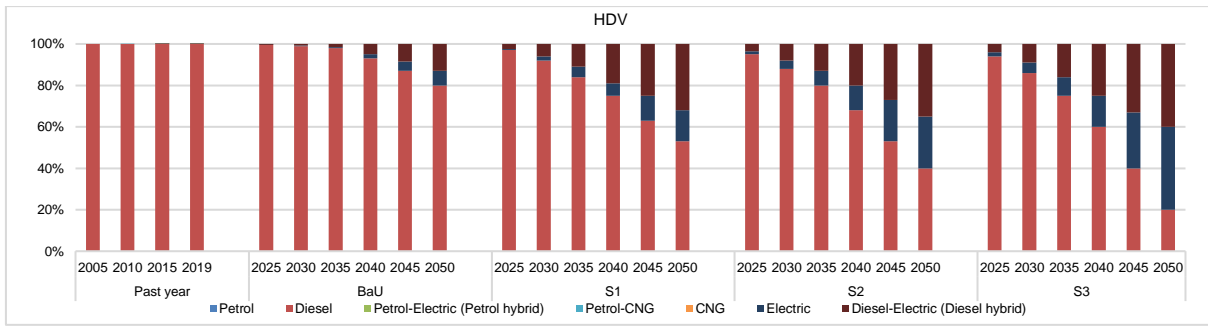

Figure 7-16: HDV share in past years and the scenarios

7.4 Results and discussion

The following figures describe the calculated air pollutants and CO₂ emission projection trends in the four scenarios. The declining trends are different for individual pollutants or emissions, mainly due to different technological improvements in combatting specific air pollutants.

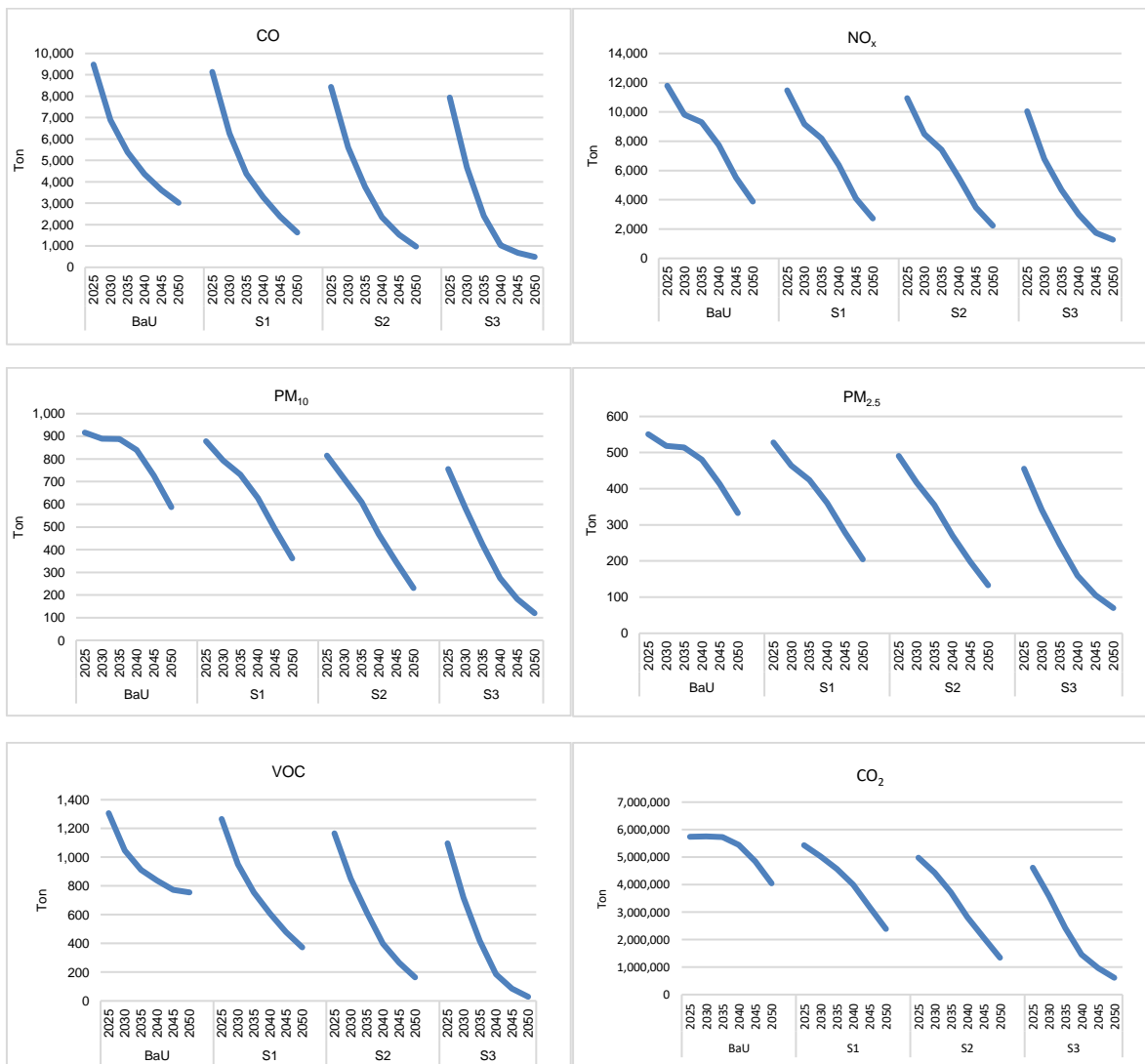

Figure 7-17: Air pollutants and CO₂ emission projections trend in the four scenarios

7.4.1 Scenario Analysis

CO

Figure 7-18 explains the declining CO trends for past and future scenarios. The total annual CO emission has decreased by a factor of 4 from 2005 to 2019. For the future scenario, a slow decline is predicted from 11.2 kt in 2019 to 0.5 kt in 2050 by using scenario S3.

Successive implementation of emission standards has led to a significant drop in CO and other pollutants such as VOC and exhaust PM. Also, the automotive industry has brought particle emissions down to near-zero levels through catalyst technologies (e.g. catalytic converters).

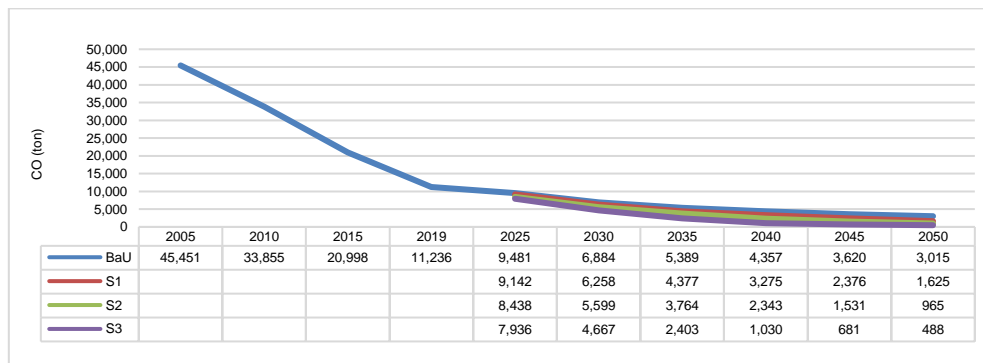

Figure 7-18: Comparison of overall CO in the four scenarios

The projection trend of CO emissions per vehicle type is shown in Figure 7-19. The massive downward trend can be seen in the MCs vehicle category in all scenarios. In terms of CO₂ emissions, an MC engine is more efficient than a car engine but emits a large amount of CO, together with HC and NO_x. The existing technologies such as catalytic converters and other emission control devices cannot clean it all up due to the immense size and heavy weight of installation in an MC. However, due to the light and small weight and volume of an MC, EV is only offered for the BEV type and is assumed to have zero CO emissions. Therefore, the CO potential reduction of this vehicle type is very high.

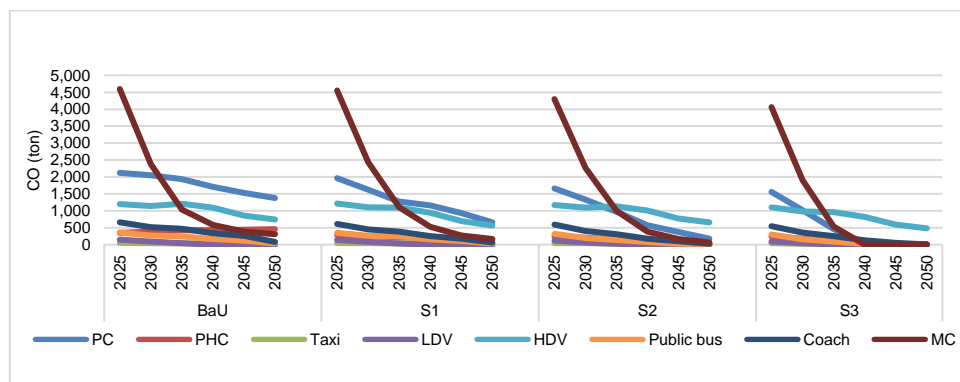

Figure 7-19: CO comparison per vehicle type in the four scenarios

NO_x

As illustrated in Figure 7-20, the NO_x emissions gradually dropped by about half from 25.1 kt to 12.3 kt between 2005-2019, due to the stringent emissions standards and exhaust after-treatment systems lean-NO_x such as catalyst and selective catalytic reduction (SCR). This trend is expected to decline moderately through EVs' penetration up to 1.3 kt, as estimated by the S3. However, the estimation of NO_x in road transport has been a controversial matter as of recently, the real-world driving test value is always higher than the announced value by emission standards and estimated by the vehicle emissions model.

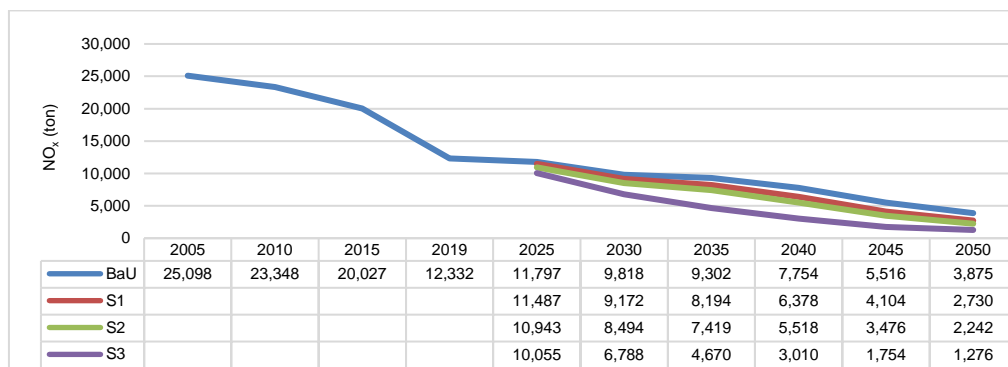

Figure 7-20: Comparison of overall NO_x in the four scenarios

The NO_x emissions projection per vehicle type is illustrated in Figure 7-21. In general, vehicles operated by diesel (HDVs, coaches, public buses) are estimated to contribute significantly to NO_x in the four scenarios continuously. The vehicle segment's EV penetration is assumed slower than in the gasoline vehicles type because the technology development in this vehicle segment is slightly behind the light vehicles. Still, NO_x offers significant emissions reduction once the technology enhancement is achieved.

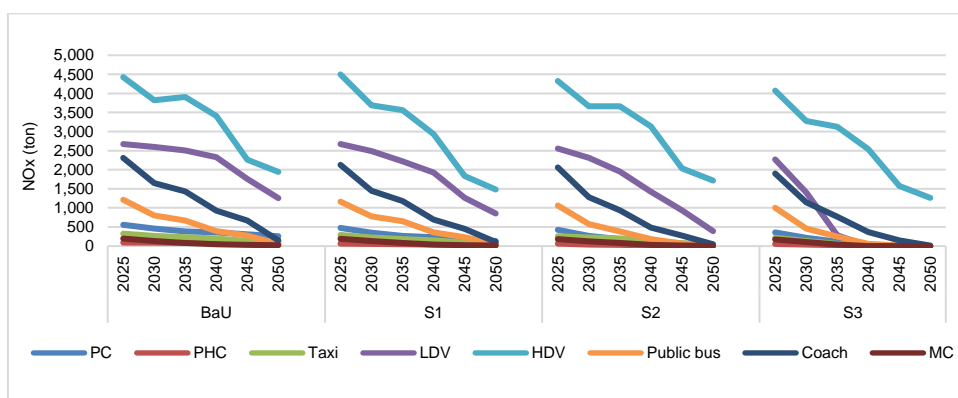

Figure 7-21: NO_x comparison per vehicle type in the four scenarios

PM (PM_{2.5} and PM₁₀, including the non-exhaust emissions)

PM shows a similar declining trend as NO_x in the past, as described in Figure 7-22. PM_{2.5} and PM₁₀ emissions were dropped by half from 2005 to 2019 but predicted to slightly up to moderately decrease through the S1, S2, and S3. However, the estimation of PM emissions in

the past and projection also includes non-exhaust sources such as tyre wear, brake wear, road surface wear, and dust resuspension. According to (Timmers and Achten 2016), PM_{2.5} emissions were only 1-3% lower for EVs than for modern ICEVs. Non-exhaust emissions already account for over 90% of PM₁₀ and 85% of PM_{2.5} emissions from traffic. It could then be concluded that EVs' increased popularity is not likely to significantly affect PM on the road.

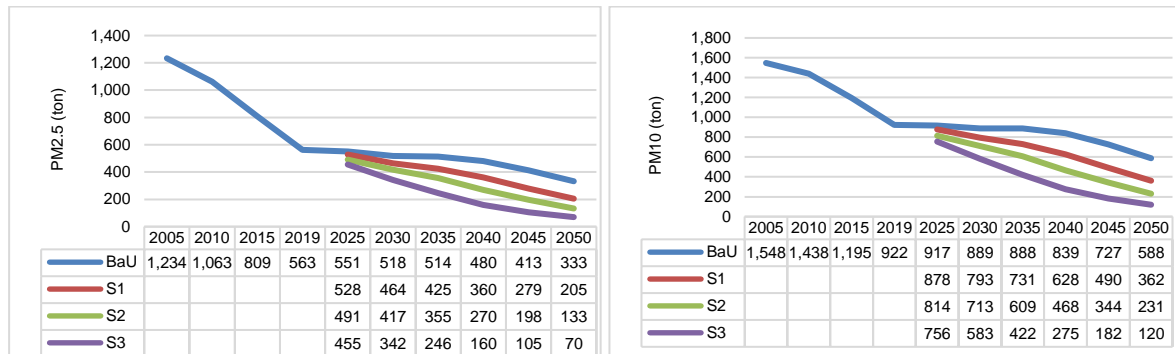

Figure 7-22: Comparison of overall PM_{2.5} and PM₁₀ in the four scenarios

Figure 7-23 and Figure 7-24 show PM_{2.5} and PM₁₀ emissions projections through four scenarios, which show a similar trend. The two highest PM shares are found in HDVs and PCs, making them the two most potential vehicle types for EV penetration and combatting air pollutants, especially PM.

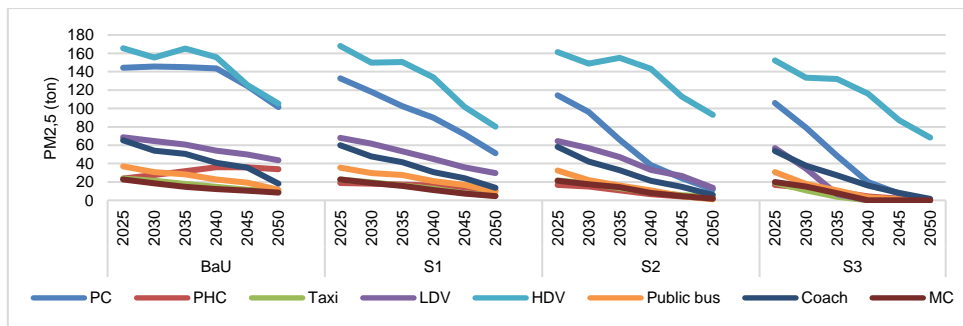

Figure 7-23: PM_{2.5} comparison per vehicle type in the four scenarios

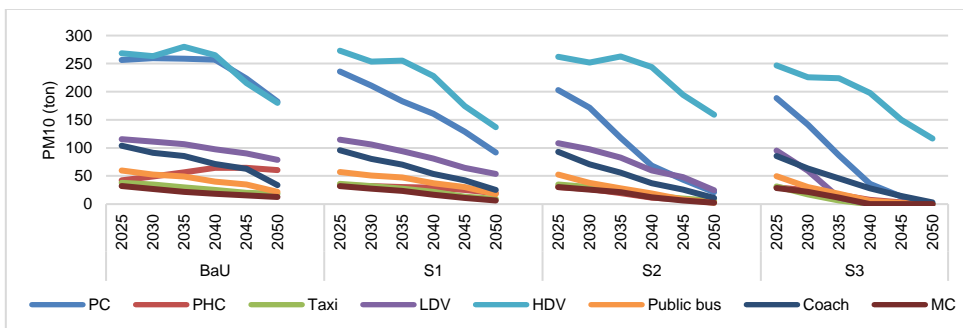

Figure 7-24: PM₁₀ comparison per vehicle type in the four scenarios

VOC

A similar decreasing movement as for CO was found in VOC. The total annual VOC was reduced by one quarter within the last sixteen years. Reducing this pollutant is predicted to drop slowly in the future under different scenarios, up to 0.1 kt in 2050 through S3 conditions.

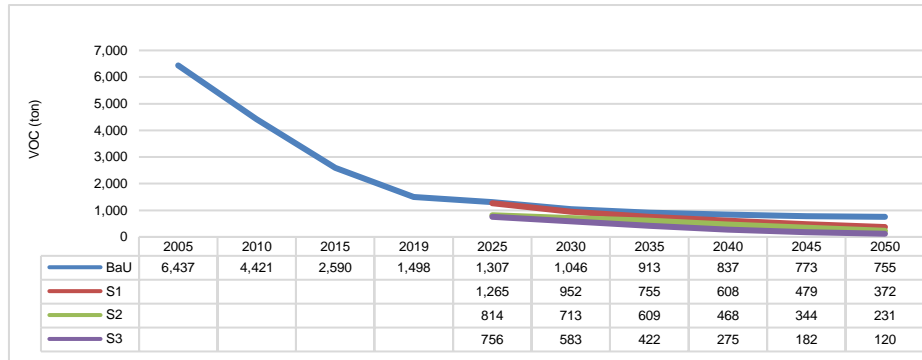

Figure 7-25: Comparison of overall PM₁₀ in the four scenarios

As illustrated in Figure 7-26, PCs and MCs are highlighted as the main contributors to VOC in 2025. In MCs, a steep drop is projected significantly in S3, mainly due to BEVs penetration. Whereas in PCs, a gradual to sharp decrease is expected through the S1 to S3 conditions.

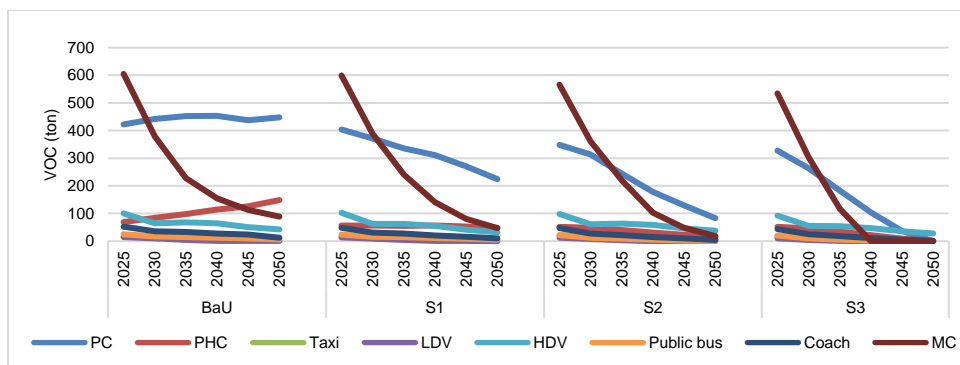

Figure 7-26: VOC comparison per vehicle type in the four scenarios

CO₂

Unlike the trend of air pollutants mentioned above, CO₂ emissions had a different trend in the past (Figure 7-27). CO₂ slowly increased from 4.9 Mt to 6.3 Mt from 2005 to 2015, then dropped slightly in 2019 to 5.7 Mt. In the BaU scenario, the trend is expected to stabilise from 2019 to 2035, then drop slightly to 4.0 Mt in 2050. Moreover, under the S1, the CO₂ projection is expected to decline slowly to 2.3 Mt in 2050. Through S2 and S3, the trend is estimated to decline more sharply to 1.3 Mt and 0.6 Mt. This fact shows a significant reduction potential through the penetration of EVs on Singapore’s roads.

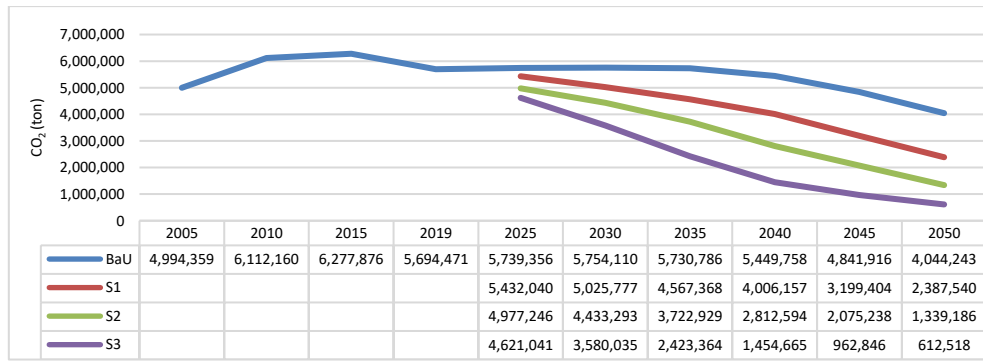

Figure 7-27: Comparison of overall CO₂ in the four scenarios

As seen in Figure 7-28, PCs and HDVs are projected to have the highest share of CO₂ emissions in 2025. However, through the gradual replacement of ICE with EV (especially for light vehicles such as PCs, PHCs), the CO₂ contribution will be lower, as shown in S1, S2 and S3.

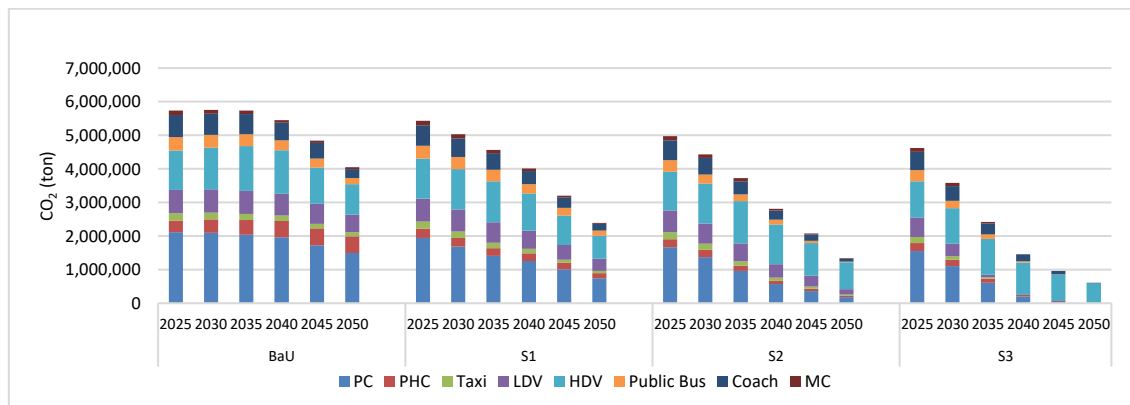

Figure 7-28: CO₂ comparison per vehicle type in the four scenarios

7.4.2 Potential emissions reduction analysis

The emissions reduction potentials are obtained by comparing the estimated emissions between the individual scenario (S1, S2, or S3) and the BaU scenario. The decreased proportions of emissions under the three EV scenarios compared to the BaU in 2050 are shown in Figure 7-29.

Compared to other scenarios, the S3 is estimated to have the most significant reduction potential for all the pollutants. A reduction of more than 75% is found for vehicle emission pollutants except for NO_x. A similar reduction trend is also observed in the S2 and S1. This estimation proves that the replacement of ICE leads to better air quality improvement. However, a single measure cannot work without additional comprehensive policies supporting EV penetration, such as a fiscal incentive policy.

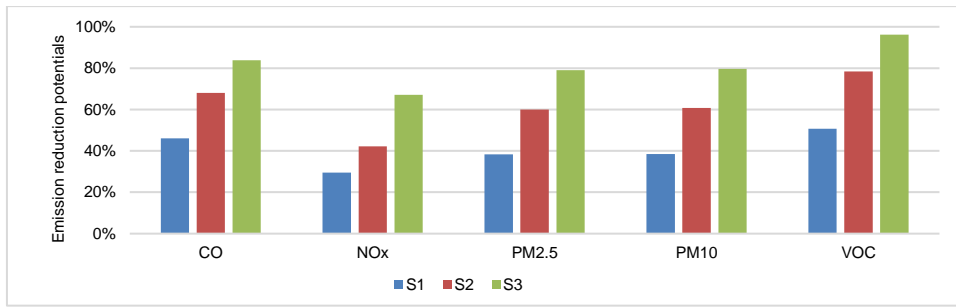

Figure 7-29: Emissions reduction potentials under the S1, S2, and S3 compared to BaU

With regards to CO₂ emissions, Figure 7-30 shows the potential emissions reduction under different scenarios. S3 offers the highest potential reduction compared to other scenarios due to ambitious ICE replacement into BEV. The reduction is about 85% in S3, 67% in S2 and 41% in S1 compared to the BaU scenario in 2050. Besides, PCs, PHCs and LDVs, seem to have a considerable potential emissions reduction potential compared to other vehicle types. Other policies could be directed towards this vehicle type as a priority if the focus is on reducing CO₂ emissions and fuel consumption.

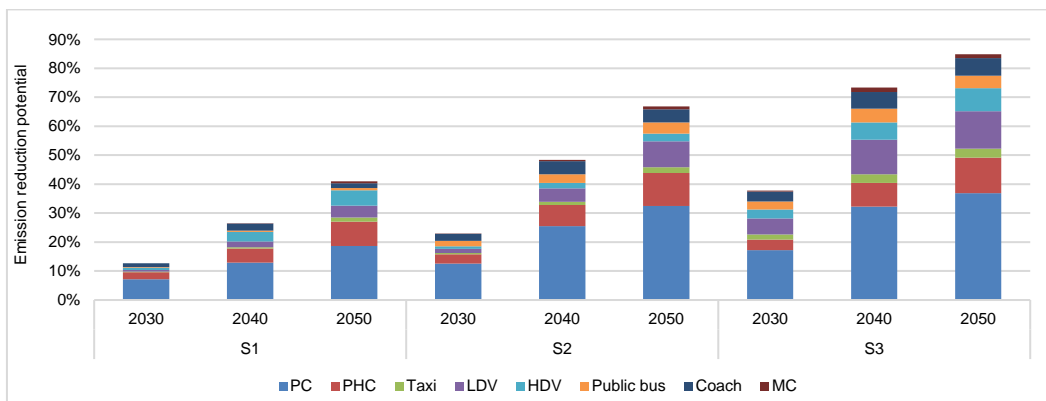

Figure 7-30: CO₂ reduction potentials under the S1, S2, and S3 compared to BaU

7.5 Limitation

Given the results mentioned above, this chapter has limitations. The analysis boundary could be enlarged into a life cycle analysis (LCA) because the emissions reduction potential also depends on electricity sources and the grey energy incorporated in the vehicles (such as battery production and recycling).

More dynamic parameters in the scenarios may have a better-projected future and influence the model estimates, including future mobility trends (such as car sharing as a separate vehicle type in the simulation) and the introduction of fuel cell electric vehicles (FCEV).

In terms of COPERT simulation for EVs scenario application, there are several assumptions taken that may generate uncertainties in the estimations, such as:

- Bi-fuel vehicles: HEVs and PHEVs are assumed to run 75% on electricity and 25% on ICE. These numbers are based on COPERT default assumption since no specific data is found for the Singapore case.
- The articulated bus is assumed as the real articulated and as the double-decker type since only a limited type of bus is available.
- The analysis of PM should be separated between the exhaust and non-exhaust emissions (as mentioned in section 8.4.1) because the contribution of non-exhaust emissions is much higher (over 90% and 85% of total PM₁₀ and PM_{2.5} from traffic) than from exhaust emissions (Timmers and Achten 2016).
- HEVs for LDVs and HDVs need to be separated in the simulation.

7.6 Conclusion

This chapter presents the potential of reducing air pollutants and CO₂ emissions of motor vehicles by expanding EVs in the Singapore vehicle fleet. Four scenarios were introduced and determined from 2025 until 2050 with an interval analysis of five years, with the base year of 2019, and under eight vehicle type categorisations.

A significant reduction was found in scenario 3 (S3), followed by scenario 2 (S2) and scenario 1 (S1) in all emissions types. The emission reduction potential differs between individual pollutants. Scenario 3 was the most ambitious plan to radically improve air quality and reduce human health risks, primarily by reducing CO, VOC, and NO_x. The detailed findings of the emissions projection in 2050 are explained below.

- CO reduction of 83%, 67% and 45% compared to the Business as Usual (BaU) could be reached if the S3, S2 and S1 are implemented.
- A similar trend to CO was identified for VOC with a reduction potential of 96% in S3, 78% in S2 and 51% in S1
- A reduction of 66%, 40% and 27% below the BaU was estimated for NO_x for S3, S2, and S1
- For PM_{2.5} and PM₁₀, a similar reduction was identified of about 78%, 58% and 35% for the S3, S2 and S1. However, this reduction is considered high since BEVs were not included in the simulation, and non-exhaust emissions were still included in the projection. If the BEVs are included in the simulation, then they will contribute significant pollutants contribution in both PM, then the reduction potential would not be as significant as calculated above.
- A slightly similar reduction was found in CO₂ and fuel consumption by the penetration of EVs in the three scenarios: S3 = 85%, S2 = 67% and S1 = 41%.

NO_x can significantly reduce tailpipe emissions due to the technically feasible and massive reduction in all technologies. This projection inherits the assumption that the divergence between real-world driving emissions and test-bed emissions will diminish in the future but not

for PM since secondary emissions from non-exhaust (tyre, brake wear and resuspension) are still an issue to be solved.

HEVs and PHEVs potentially offer to reduce local pollutants and global CO₂ emissions; however, they strongly depend on their real-world fuel consumption and the share of kilometres driven by electricity. Therefore, defining the mileage share assumption based on accurate driven data for typical Singapore driving behaviour is necessary.

Assessing emissions of EVs is a challenging task since different assessment methods may lead to conflicting results. The composition of vehicle fleets has an enormous impact on future air pollutants and emissions. Increasing EVs share contributes to decreasing local air pollutants and reducing oil import dependence, but for Singapore, an even higher dependency on CNG import is expected for electrification unless other renewable energy options are in place. Moreover, as EVs become popular, they also pose another environmental challenge, as the batteries need to be recycled sustainably. This issue needs to give more attention in the near future.

This simulation-based approach is conducted to understand the potential air pollutants and CO₂ emissions reduction of EVs introduction under the four scenarios. The result offers insight into environmental management solutions in the road transport sector. These findings can be considered by related stakeholders and the government in formulating policies to speed up the EVs adaptation in Singapore and achieve Singapore Green Plan 2030 and other strategic plans.

8 Findings, Conclusion and Recommendation

8.1 Summary

Globally, road transport is a significant contributor to air pollution and climate change. Nations have given more attention to solving these concerns, including Singapore. The state has often been set as a successful benchmark for transport and land-use planning integration policies, including several landmark policy initiatives such as vehicle growth rate control (VGR) and electronic road pricing (ERP). This study is motivated by the limited research on the environmental impact (air pollutants and CO₂ emission) of transport activities in Singapore, even though several sustainable transport policies have been implemented and specific environmental targets have been set.

This dissertation presents how and to what extent the existing emissions models apply to Singapore's urban area emissions estimation. This intention is complemented by vehicle fleet development and emissions inventory estimation for 2004-2019. Considering uncertainties in the estimation, the study identified aggregated emissions factors (EFs) from air quality measurements at the Kallang Paya-Lebar (KPE) tunnel expressway and conducted open road measurements. Moreover, estimation of potential air pollutants and emissions reduction by penetration of electric vehicles (EV) is introduced in four future scenarios up to the year 2050.

Following the introduction, vehicle emissions from road transport are presented as part of the literature review, where several topics were addressed, including pollutants emitted by motor vehicles, factors influencing emission on the road, and regulated vehicle emission standards. Furthermore, vehicle emissions measurements and EFs development are examined. Essential ingredients of emissions estimation, such as the state-of-the-art emissions models, are also highlighted.

Various emissions models' analysis reveals the issue of selecting a proper emissions model since no specific emissions model can accommodate all conditions. A procedure is identified for application-specific emissions model selection. Pragmatic emissions model selection criteria are developed based on literature review and lessons learnt from different applications in the last twenty years. A suitable emissions modelling approach is recommended for Singapore and used in this dissertation.

A separate independent (not part of the emissions model) Singapore vehicle fleet model is established as a tool to understand the dynamics of vehicle development, traffic activities and local characteristics on the road. Several evidence lines are used to build the vehicle fleet model based on the statistical data inputs from publicly available data sources and secondary

sources. This tool can be used for further emissions estimations, future emissions projections, and amending relevant transport-environment policies at a macroscopic level.

An average speed emissions model, COPERT is applied at a city-state scale in Singapore to develop emissions inventory in road transport for 2004-2019. The estimation is based on two approaches: (1) bottom-up, derived from road traffic activities and (2) top-down, derived from fuel consumption in the road transport sector. The results of bottom-up and top-down approaches are compared and presented to identify the calculations' level of agreement and consistency.

Road transport emissions have been estimated at a city-state scale. However, the analysis entails several uncertainties such as EFs, traffic characteristics and the fuel used. At a link level, NTU-LTA (Nanyang Technological University - Land Transport Authority) project was given an excellent opportunity to determine the aggregated EFs through the Kallang Paya-Lebar Expressway (KPE) case tunnel. Tunnel studies have proven to be robust and economically friendly for obtaining aggregated EFs under real-world conditions. The characteristics of the KPE tunnel, experimental measurement, preliminary result and EFs estimation are identified and explained. However, due to the data quality issues, only aggregated EFs of CO and NO are determined. The estimated aggregated EFs are compared with other tunnel studies to check the results' consistency for reliability.

EVs have been considered environmentally friendly alternatives in the road transport sector compared to internal combustion engine vehicles because they reduce fossil fuel dependency and emissions while driving. However, the impact of EVs introduction on the road on emissions reduction varies greatly, mainly depending on the country's electricity mix. Currently, 95% of Singapore's electricity is produced using imported natural gas since other renewable energy options are not yet viable due to the limited surface area.

The government is encouraging EV adoption in Singapore as a part of green mobility efforts. Four different scenarios of EVs are introduced and analysed in the Singapore fleet to investigate the potential of reducing air pollutants and CO₂ emissions. Challenges and obstacles to EV adoption are also discussed. Furthermore, recommendations for the most promising scenario, which can support future environmentally-friendly mobility, are also presented.

8.2 Findings

The findings are explained in accordance with the objectives of the research.

Various factors affecting motor vehicles' emissions are identified and classified into vehicle characteristics, road infrastructure characteristics, traffic situation, vehicle operation, meteorological, and other external factors related to the case country or study. However, several limitations, such as data availability and quality, impacted emissions estimation. Numerous local characteristics are found in Singapore, including unique vehicle fleet composition. The average car's age profile is younger due to effective inspection and maintenance implementation, high use of air conditioners due to high humidity and relatively high regular and strong regulation of vehicle management and use, such as vehicle growth rate control (VGR) control and certificate of entitlement (COE).

Transport-related emissions modelling has gained more attention in the last two decades, as observed by the model development at different levels (from link to national level). There is no perfect emissions model, but different models can provide a valuable estimation of road traffic emissions. To implement and monitor sustainability policies, decision-makers need to be confident in this assessment. Also, society needs to be informed that their travel methods can contribute to better air quality and climate change mitigation.

An appropriate emissions modelling approach that corresponds to the specific purpose and area of intention should be selected to maximise an emissions model's effectiveness. Therefore, the process and criteria are defined for selecting a modelling approach for an application. This dissertation summarises the criteria for selecting appropriate emissions models, including the following internal criteria (modelling objective, resolution, approach, and data availability) and external criteria (local condition and practicability) (Section 3.2). An overview of the existing emissions models and the influence factors of traffic emissions are also obtained. Additionally, these criteria can be utilised to facilitate essential dialogues with related stakeholders, facilitating the development of strategic plans and decisions based on projected emissions model results.

A suitable emissions model is applied for Singapore with the criteria mentioned above by following the selection process method. Considering all the criteria, especially the data availability and some local conditions, a recommendation is developed to estimate emissions by using an average speed emissions model, such as COPERT, with the intention of developing an emissions inventory.

Vehicle-fleet development and local transport characteristics are determined from 2004-2019 based on collected data and certain essential assumptions to accommodate the COPERT

emissions model for emissions inventory purposes. Sufficient detail of motor vehicle data is available for various fleet sub-segments, but unfortunately, without correlations among those sub-segments. Several assumptions are taken to build the broken correlation among these fleet sub-segments.

Currently, the fleet model's quality is entirely satisfactory for the preferred average speed emissions model, COPERT. In general, vehicle population and fleet characteristics in Singapore are strongly affected by a string of transportation management policies such as vehicle ownership control. Some highlights of the vehicle fleet are identified below.

- Singapore's total fleet grew by 33% over the last sixteen years, with passenger cars (PCs) on the road leading the rise from 409,648 cars in 2004 to 553,455 cars in 2019 (Section 4.3, Figure 4-2);
- The rapid development of private hire cars (PHCs), such as Uber and Grab, is one of the highlights of the period, especially between 2014 with about 18,847 vehicles to 77,141 vehicles in 2019 (Section 4.3, Figure 4-2);
- The average car age is 5.47 years for 2019. Cars (including PHC, but taxis are excluded) of this age are considered relatively young and efficient as resulting of numerous policies (Section 4.4.3, Figure 4-10);
- Diesel-powered vehicles are dominant with a percentage of 66% on Singapore's roads considering the total vehicle's activities (vehicles kilometres travelled, VKT) (Section 4.4.1);
- There is a trend toward cleaner vehicles, EVs, mainly for taxis, private hire cars (PHCs), passenger cars (PCs,) and public buses (Section 4.4.1);
- For VKT, a steady movement is found in motorcycles (MCs), light-duty vehicles (LDVs), heavy-duty vehicles (HDVs) and public buses (Section 4.5.2);
- A clear declining VKT is identified in taxis due to the newcomer PHCs in recent years resulting from the disruptive mobility stage of a technology life (Section 4.5.2);
- The average speed remains constant in Singapore, primarily due to the ERP policies and vehicle growth rate control (VGR) (Section 4.5.3).

The modelled vehicle fleet and its travel activity are applied in the COPERT to estimate annual road transport emissions (CO, NO_x, PM_{2.5}, PM₁₀, VOC and CO₂) in Singapore from 2004 to 2019. The trends for CO, NO_x, VOC, PM_{2.5} and PM₁₀ show that emissions levels declined gradually, even though the vehicle population increased during this period. The detailed results are explained below (see Section 5.4 for details).

- The total CO emissions declined drastically, by about 10% per annum, from 48.8 kt in 2004 to 11.2 kt in 2019. The reduction is about one-fourth over the last sixteen years.

Motorcycles (MCs) and passenger cars (PCs) are the most significant contributors to CO decrease. Improvement technologies (such as the application of catalytic converters) and tightening emission standards are also identified as the main contributors to the reduction;

- A significantly declining trend is observed for VOC emissions from 2004 to 2019. VOC emissions decreased by approximately 10% on average per annum, from 7.1 kt in 2004 to 1.5 kt in 2019. The primary reason for the decline was the implementation of a more stringent emission standard and the increased use of catalytic converters;
- The NO_x emissions follow a slightly different declining trend, with a slow reduction curve from 2004-2014 (annual growth rate reduction of 2%) and a significant drop from 2015-2019 (annual growth rate reduction of 11%). This reduction primarily results from the tightening of the regulatory limit from Euro II to Euro IV for diesel vehicles from 2004 to 2019 was mainly caused the reduction;
- The PM_{2.5} and PM₁₀ emissions (exhaust and non-exhaust) also show decreasing trends. The PM pollutants are closely related to diesel vehicles as significant contributors. PM_{2.5} emissions decreased moderately, from 1.3 kt in 2004 to 0.6 kt in 2019. A similar trend is also found for PM₁₀; the reduction in 2019 was one-third of 2014 (1,5 kt to 0.9 kt);
- CO₂ emissions increased gradually, with an annual growth of 4% from about 4.7 Mt in 2004, having peaked at 6.3 Mt in 2011. Emissions rose due to increased total vehicle kilometres travelled (VKT) and fuel consumption from 2004 to 2011. Since 2012, CO₂ emissions remained stable until 2015; then, a moderate decline was identified in 2016 with about 6.1 Mt to 5.7 Mt in 2019.

CO₂ emissions determined based on the fuel sales principle are higher than estimated based on inhabitants' traffic activity using an average speed emissions model COPERT with an average annual absolute difference value of 20%. However, both approaches are consistent in showing the increasing CO₂ emissions trend within the period 2004-2011 with an annual average growth of 4%. Beyond 2011, no fuel sales data were identified.

The Kallang Paya-Lebar (KPE) tunnel air quality measurement was conducted in 2015. The overall quality of the data collected was generally satisfactory, but several improvements are recommended for future tunnel experiments. The aggregated EF results estimated that CO=1.46 g/veh-km and NO_x=0.28 g/veh-km (Section 6.1.4). However, compared to past tunnel studies performed in other parts of the world, both EFs are lower, indicating that Singapore's fleet is generally cleaner. Furthermore, as a follow-up to the tunnel research, open road measurements were carried out in a limited time frame to determine EF in various

traffic conditions. Lessons learned are gathered and summarized while considering data quality and outcome constraints (Section 6.2.5).

Four scenarios are introduced, namely business as usual (BaU), scenario 1 (low EVs penetration), scenario 2 (medium EVs penetration) and scenario 3 (high EVs penetration). The scenarios are determined to identify the future potential reduction of road vehicles' air pollution and CO₂ emissions. The future emissions projection was built with five years intervals from 2025 to 2050. The dynamic variables influencing each scenario's projection include the vehicle growth rate, vehicle kilometre travelled (VKT), and EV fleet penetration rate.

In general, a significant reduction is found in scenario 3 (S3), followed by scenario 2 (S2) and scenario 1 (S1) in all emissions types. Scenario 3 is the most ambitious plan to radically improve air quality and reduce personal health risks, especially CO, VOC, and NO_x. The detailed findings of the emissions projection in 2050 are explained below.

- A CO reduction of 83%, 67% and 45% could be reached compared to the BaU if the S3, S2 and S1 are implemented;
- A similar declining trend to CO is identified for VOC with a reduction potential of 96% in S3, 78% in S2 and 51% in S1;
- A reduction of 66%, 40% and 27% below the BaU is estimated for NO_x for S3, S2, and S1. The reduction potential of NO_x in various scenarios is considered to be lower than for other air pollutants, given the fact that the transition from diesel vehicles, particularly those used for logistics (such as light-duty and heavy-duty vehicles) to EVs, has been slower than for typical gasoline light vehicles (e.g. passenger cars, taxis, motorcycles);
- For PM_{2.5} and PM₁₀, a reduction of about 78%, 58% and 35% is predicted for the S3, S2 and S1. However, this reduction is considered high since the EVs fleet is not included in the simulation, and non-exhaust emissions are still included in the projection;
- CO₂ and fuel consumption are also expected to reduce with the penetration of EVs in the three scenarios with S3 = 85%, S2 = 67% and S1 = 41%.

8.3 Conclusion

In recent years, road transport emissions have become a significant threat to deteriorating air quality. Moreover, human health impacts from road transport are more hazardous as the emissions tend to happen in areas where most people live and work, such as in urban areas. Therefore, it is necessary to estimate the amount of road transport emissions accurately. The

estimation helps in the mitigation of the adverse effects on public health and climate change. As a result, numerous transport emission models have been developed and applied to investigate the environmental effects of transport activities.

Globally, emission models are reviewed, and the process of selecting a suitable emissions model approach is identified. In general, each emissions model tends to have different intentions, and characteristics regarding scope, input data approaches methods and outputs. Thus, there is no single model that fits well in all situations, but at least there is a way to reduce the uncertainties of emissions estimation by applying the identified process for selecting an appropriate emissions model approach that fits the case study. The selection process provides a good foundation and direction for further developments of the emissions model for Singapore. Due to the limited data availability (such as EFs, driving cycle for all vehicle types), and some other local constraints, the average speed emissions model is chosen for Singapore.

Singapore's typical vehicle fleet model is developed to identify and analyse the vehicle fleet characteristics, and other local transport attributes for 2004-2019. This tool helps the stakeholders, especially the related authorities, to optimise the ongoing and future policy measures for sustainable mobility. Furthermore, the model is able to manage the data and compute the Singaporean vehicle fleet from 2004-2019 as an input of road transport emissions estimation using the average speed model COPERT and a basis point for future fleet projection and scenario analysis.

Specific air pollutants (CO, NO_x, PM_{2.5}, PM₁₀, VOC) and CO₂ emissions have been estimated for the same year as the fleet model using the bottom-up approach (COPERT). The emissions loads for all pollutants showed a decreasing trend in the period studied. Specifically for the local context in Singapore, the air pollutants and emissions reductions happened due to a series of transportation policies, such as the vehicle growth rate (VGR) control, vehicle quota system (VQS), certificate of entitlement (COE), and the combination of other fiscal measures (e.g., vehicle taxes, early turn over scheme), which impacted the higher turnover rate of vehicles. Besides the intervention policies mentioned above, vehicle manufacturers have accomplished emissions reduction targets mainly by implementing technological solutions in progressive emission control technologies utilisation such as exhaust catalysts.

A top-down (fuel-based) approach is also used to estimate the CO₂ emissions based on fuel consumption data and check the result's consistency with the bottom-up approach. However, a significant difference of 20% was found between the top-down and bottom-up approaches. This difference might be reduced if other fuel users are considered in the estimation (e.g.,

vehicles from the neighbouring country Malaysia and the off-road and non-road sector), and the detailed data of the bottom-up approach are improved). Nevertheless, it is preferable to start developing a vehicle fleet model and emissions model with limited data. More comprehensive data and a more advanced methodological emissions model such as the traffic situation model can later be used to predict air pollutants and emissions estimation better.

The tunnel study is the first research on real-world vehicle EFs determination conducted in a tunnel in South-East Asia. The road tunnel measurements were conducted at Kallang Paya-Lebar Expressway (KPE) tunnel in 2015. In this study, real-world aggregated EFs of CO and NO_x are identified for CO=1.46 g/veh-km and NO_x=0.28 g/veh-km. These estimated values are considered lower compared to other determined EFs in previous tunnel studies around the world. Moreover, the results validate that the estimated EFs from the emissions model (COPERT) are overestimated. Data collected from the open road experiment were insufficient to determine the EFs to be within an acceptable range (Section 6.2.4). Still, both tunnel and open road studies provide a reasonable basis for further validation of the existing emissions model and an excellent foundation for developing the local emissions model.

In general, the vehicle fleet in Singapore is clean, resulting of a series of strong transportation policies (such as VGR and COE). Still, further verification is needed by conducting more tunnel studies or other real-world measurements. More real-world emissions measurements are needed to inform society with accurate emissions information and avoid misleading information or scandals (e.g. Volkswagen emissions scandal, Section 2.3). Combining both approaches (real-world measurements and simulation-based) in a local study environment is the most effective way to obtain complete traffic emissions information and improve emissions estimation.

Potential air pollutants and emissions reduction by penetration of EVs are estimated under different scenarios. The results provide insights into improving the air quality and support the global climate change issue on a compact city-state scale in Singapore. However, EVs create an additional burden for the energy sector since the emissions are shifted to this sector due to electrification in road transport. Only with clean energy, the implementation of electrification in Singapore will be environmentally sustainable. From a broader future mobility perspective, the adoption of EVs in Singapore should be highlighted as replacing internal combustion engine vehicles and complementing other environmentally friendly mobility options such as walking, cycling, and public transport.

This study also proves that the successful implementation of comprehensive sustainable transport policies in Singapore addresses not only climate change but also air quality

problems. The implemented transport policies in Singapore executed experimental and simulation-based methodologies, estimated results, conclusions, and lessons learned from this study are expected to have applicability in several South-East Asian cities.

8.4 Recommendations for further research

Alongside above mentioned significant findings, this dissertation leaves room for improvement, as summarised in the following recommendations:

- Improving and maintaining data quality for better emissions quantification is needed by engaging diverse stakeholders (e.g. Land Transport Authority - LTA, National Environmental Agency - NEA, Energy Market Authority - EMA, vehicle inspection companies, research institutions, NGOs);
- According to the study, the following data need to be identified or improved:
 - Vehicle type by emissions standards has to be identified, and there is a need to correlate the data within vehicle sub-segments;
 - Fuel sales data need to be updated from trustworthy government institutions, as the existing fuel sales data is published by the World Bank and the documented year is only until 2011;
 - The detailed vehicle travelled activities have to be updated (e.g. per detailed vehicle type and or per fuel type, with distribution in different road categories);
 - Fuel quality data needs to be identified as it influences the calculated vehicle emissions;
 - A driving cycle is only available for passenger cars. Different driving cycles for other vehicle types are needed to improve the emissions estimation.
- Future research should concentrate on the following topics:
 - An integrated approach model between transport (including rail transport), fleet and emissions model is needed to estimate the dynamic impact of transport activities closer. For instance, the integration of VISUM and average speed/traffic situation model (COPERT/HBEFA) at a macroscopic or VISSIM and MOVES at a microscopic level;
 - A continuity of tunnel measurements at a similar segment of the tunnel is required to derive the updated EFs and monitor transport policies' impact. Ten years interval is recommended;
 - Other real-world measurements (tunnels and open roads) are needed to verify the estimated emissions from the emissions model. Better air quality monitoring equipment and well-prepared methods need to be carefully prepared to achieve an effective measurement, good data quality and better results;

- For a further scenario-based study on the impact of EVs on emissions, the energy supply and vehicle production emissions need to be included in estimating future CO₂ emissions projections.

9 Publication bibliography

Abou-Senna, Hatem; Radwan, Essam; Westerlund, Kurt; Cooper, C. David (2013): Using a traffic simulation model (VISSIM) with an emissions model (MOVES) to predict emissions from vehicles on a limited-access highway. In *Journal of the Air & Waste Management Association* 63 (7), pp. 819–831. DOI: 10.1080/10962247.2013.795918.

ACEA (2019): ACEA Report. Vehicles in use - Europe 2019. ACEA.

AGC (2021): Restriction of Speed on Roads (Road Traffic). Available online at <https://sso.agc.gov.sg/SL/RTA1961-N6?Timeline=On#pr3->.

Agyemang-Bonsu, K. W.; Dontwi, I. K.; Tutu-Benefoh, D.; Bentil, D. W.; Boateng, O. G.; Asuobonteng, K.; Agyemang, W. (2010): Traffic-data driven modelling of vehicular emissions using COPERT III in Ghana: A case study of Kumasi. In *American Journal of Scientific and Industrial Research*.

Ahn, Kyounggho; Rakha, Hesham (2008): The effects of route choice decisions on vehicle energy consumption and emissions. In *Transportation Research Part D: Transport and Environment* 13 (3), pp. 151–167. DOI: 10.1016/j.trd.2008.01.005.

Allan, L.; J. Tao (2015): Singapore Country Report' in Kimura, S. and P. Han (eds.) in Energy Outlook and Energy Saving Potential in East Asia 2016. ERIA Research Project Report 2015-5. Jakarta. Available online at https://www.eria.org/uploads/media/Books/2021-Energy-Outlook-and-Saving-Potential-East-Asia-2020/22_Ch.15-Singapore-1603.pdf.

Ameur-Bouddabbous, I.; Kasperek, J.; Barbier, A.; Harel, F.; Hannover, B. (2012): Transverse approach between real-world concentrations of SO₂, NO₂, BTEX, aldehyde emissions and corrosion in the Grand Mare tunnel. In *Journal of Environmental Sciences* 24 (7), pp. 1240–1250. DOI: 10.1016/S1001-0742(11)60936-4.

Amirjamshidi, Glareh; Roorda, Matthew J.; Mostafa, Toka S.; Misra, Aarshabh (2013): Microsimulating Emissions and Population Exposure in Downtown Toronto. Department of Civil Engineering, University of Toronto. Available online at <https://ctrf.ca/wp-content/uploads/2014/07/2AmirjamshidietalMicrosimulating.pdf>.

Andre, M; Rapone, M; Adra, N; Pollak, I; Keller, M; McMrae, I (2006): Traffic characteristics for the estimation of pollutant emissions from road transport. ARTEMIS WP1000 project. ARTEMIS - Assessment and reliability of transport emission models and inventory systems. Report INRETS-LTE 0606. With assistance of the European Commission within The 5th Framework Research Programme. INRETS-LTE. Bron France.

Anenberg, Susan C.; Miller, Joshua; Henze, Daven K.; Minjares, Ray; Achakulwisut, Pattanun (2019): The global burden of transportation tailpipe emissions on airpollution-related mortality in 2010 and 2015. In *Environ. Res. Lett.* 14(2019)094012. DOI: 10.1088/1748-9326/ab35fc.

APEC (2017): The Impact of Government Policy on Promoting New Energy Vehicles (NEVs). The Evidence in APEC Economies. Available online at <https://www.apec.org/Publications/2017/03/The-Impact-of-Government-Policy-on-Promoting-New-Energy-Vehicles-NEVs--The-Evidence-in-APEC-Economie>.

Atjay, Delia Elisabeta (2005): Modal Pollutant Emissions Model of Diesel and Gasoline Engines. Dissertation. Swiss Federal Institute of Technology Zurich, Zurich. Available online at <https://www.dora.lib4ri.ch/empa/islandora/object/empa%3A12271>.

Bai, Song; Eisinger, Douglas; Niemeier, Deb (2008): MOVES vs. EMFAC: A comparative assessment based on a Los Angeles County Case Study. University of California.

Barlow, T J (2013): Available traffic emission models. Presented in the Road Transport Emission Simulation in the Context of South East Asia Seminar.

Barlow, T. J.; Boulter, P. G. (2009): Emission factors 2009. Report 2 – a review of the average-speed approach for estimating hot exhaust emissions; PPR355. Available online at https://assets.publishing.service.gov.uk/government/uploads/system/uploads/attachment_data/file/4248/report-2.pdf.

Barth, Matthew; An, Feng; Norbeck, Joseph; Ross, Marc (2000): Development of Comprehensive Modal Emissions Model. Operating Under Hot-Stabilized Conditions.

Bigazzi, Alexander; van Lint, J.W.C.; Klunder, Gerdien; Stelwagen, Uilke; Ligterink, Norbert (2010): Traffic data for local emissions monitoring at a signalized intersection. In *13th Int. IEEE Conf. Intell. Transp. Syst.*, pp. 210–215. DOI: 10.1109/ITSC.2010.5625302.

Bishop, Gary A.; Stedman, Donald H.; Ashbaugh, Lowell (1996): Motor Vehicle Emissions Variability. In *Journal of the Air & Waste Management Association* 46, 1996 - Issue 7, pp. 667–675. DOI: 10.1080/10473289.1996.10467501.

Boey, Augustin; Su, Bin (2014): Low-carbon Transport Sectoral Development and Policy in Hong Kong and Singapore. In *Energy Procedia* 61, pp. 313–317. DOI: 10.1016/j.egypro.2014.11.1114.

Borge, Rafael; Miguel, Isabel de; La Paz, David de; Lumbreras, Julio; Pérez, Javier; Rodríguez, Encarnación (2012): Comparison of road traffic emission models in Madrid (Spain). In *Atmospheric Environment* 62, pp. 461–471. DOI: 10.1016/j.atmosenv.2012.08.073.

Boulter, P. G. (2012): A city-wide road traffic emission model for Oxford-scoping report. Bracknell: IHS (Published project report, 0968-4093, PPR474).

Boulter, P. G.; Barlow, T J; McCrae, I S; Latham, S (2009): Emission factors 2009. Final summary report. Bracknell: IHS (Published project report, 0968-4093, PPR361).

Boulter, P. G.; Mccrae, I. S. (2007a): ARTEMIS. Assessment and reliability of transport emission models and inventory systems: final report / P.G. Boulter and I.S. McCrae (eds). Wokingham: TRL (TRL published report, PPR350).

Boulter, P. G.; Mccrae, I. S. (2007b): The links between micro-scale traffic, emission and air pollution models. Wokingham: TRL Ltd (Published project report (Transport Research Laboratory), 0968-4093, PPR269).

Boulter, P. G.; Mccrae, I. S.; Barlow, T. J. (2007a): A review of instantaneous emission models for road vehicles. Wokingham: TRL Ltd (Published project report (TRL Limited), 0968-4063, PPR267).

Boulter, P. G.; Mccrae, I. S.; Barlow, T. J.; Report, Published Project (2007b): An evaluation of instantaneous emission models. TRL. Available online at <https://trid.trb.org/view/841102>.

CARB (2021): EMFAC2021. Volume III Technical Document. Version 1.0.1 April, 2021. California Air Resources Board. California.

Chambliss, Sarah; Miller, Josh; Facanha, Cristiano; Minjares, Ray; Blumberg, Kate (2013): Impact of stringent fuel and vehicle standards on premature mortality and emissions. ICCT's Global Transportation Health and Climate Roadmap Series. ICCT.

Chang, Shuenn-Chin; Lin, Ta-Hsiung; Lee, Chung-Te (2009): On-road emission factors from light-duty vehicles measured in Hsuehshan Tunnel (12.9 km), the longest tunnel in Asia. In *Environmental monitoring and assessment* 153 (1-4), pp. 187–200. DOI: 10.1007/s10661-008-0348-9.

- Chen, Fei; Hu, Wei; Zhong, Qin (2013): Emissions of particle-phase polycyclic aromatic hydrocarbons (PAHs) in the Fu Gui-shan Tunnel of Nanjing, China. In *Atmospheric Research* 124, pp. 53–60. DOI: 10.1016/j.atmosres.2012.12.008.
- Chen, Ku; Yu, Lei (2007): Microscopic Traffic-Emission Simulation and Case Study for Evaluation of Traffic Control Strategies. In *Journal of Transportation Systems Engineering and Information Technology* 7 (1), pp. 93–99. DOI: 10.1016/S1570-6672(07)60011-7.
- Cheng, Y.; Lee, S. C.; Ho, K. F.; Louie, P.K.K. (2006): On-road particulate matter (PM_{2.5}) and gaseous emissions in the Shing Mun Tunnel, Hong Kong. In *Atmospheric Environment* 40 (23), pp. 4235–4245. DOI: 10.1016/j.atmosenv.2006.04.002.
- Chiang, Hung-Lung; Hwu, Ching-Shyung; Chen, Shih-Yu; Wu, Ming-Ching; Ma, Sen-Yi; Huang, Yao-Sheng (2007): Emission factors and characteristics of criteria pollutants and volatile organic compounds (VOCs) in a freeway tunnel study. In *Sci. Total Environ.* 381 (1-3), pp. 200–211. DOI: 10.1016/j.scitotenv.2007.03.039.
- Chin, Anthony T. H. (2000): Sustainable urban transportation. Abatement and control of traffic congestion and vehicular emissions from land transportation in Singapore. In *Environ Econ Policy Stud* 3 (4), pp. 355–380. DOI: 10.1007/BF03354046.
- Choma, Ernani Francisco; Ugaya, Cássia Maria Lie (2017): Environmental impact assessment of increasing electric vehicles in the Brazilian fleet. In *Journal of Cleaner Production* 152, pp. 497–507. DOI: 10.1016/j.jclepro.2015.07.091.
- Clean Air Asia (2012): Accessing Asia Air Pollution and Greenhouse Gas Emissions Indicators for Road Transport and Electricity. Clean Air Asia. Metro Manila.
- Colberg, Christina A.; Tona, Bruno; Stahel, Werner A.; Meier, Markus; Staehelin, Johannes (2005): Comparison of a road traffic emission model (HBEFA) with emissions derived from measurements in the Gubrist road tunnel, Switzerland. In *Atmospheric Environment* 39 (26), pp. 4703–4714. DOI: 10.1016/j.atmosenv.2005.04.020.
- Continental (2019): Worldwide Emission Standards and Related Regulations. Passenger Cars / Light and Medium Duty Vehicles May 2019. Available online at https://www.continental-automotive.com/getattachment/8f2dedad-b510-4672-a005-3156f77d1f85/EMISSIONBOOKLET_2019.pdf.
- Corsmeier, U.; Kohler, M.; Vogel, B.; Vogel, H.; Fiedler, F. (2005): BAB II. A project to evaluate the accuracy of real-world traffic emissions for a motorway. In *Atmospheric Environment* 39 (31), pp. 5627–5641. DOI: 10.1016/j.atmosenv.2004.08.056.
- Cui, Min; Chen, Yingjun; Tian, Chongguo; Zhang, Fan; Yan, Caiqing; Zheng, Mei (2016): Chemical composition of PM_{2.5} from two tunnels with different vehicular fleet characteristics. In *Sci. Total Environ.* 550, pp. 123–132. DOI: 10.1016/j.scitotenv.2016.01.077.
- Data.gov.sg (2016): Road Traffic Conditions during Peak Hours. With assistance of LTA.
- Data.gov.sg (2018): Annual Mileage for Private Motor Vehicles. the Government Technology Agency of Singapore. Available online at <https://data.gov.sg/dataset/annual-mileage-for-private-motor-vehicles>.
- Davison, Jack; Bernard, Yoann; Borken-Kleefeld, Jens; Farren, Naomi J.; Hausberger, Stefan; Sjödin, Åke et al. (2020): Distance-based emission factors from vehicle emission remote sensing measurements. In *The Science of the total environment* 739, p. 139688. DOI: 10.1016/j.scitotenv.2020.139688.

Demir, Emrah; Bektaş, Tolga; Laporte, Gilbert (2014): A review of recent research on green road freight transportation. In *European Journal of Operational Research* 237 (3), pp. 775–793. DOI: 10.1016/j.ejor.2013.12.033.

Dieselnet (2021): Emission Standards. Summary of worldwide engine and vehicle emission standards.

Dora, Carlos; Hosking, Jamie; Mudu, Pier; Fletcher, Elaine Ruth (2011): Urban Transport and Health. Sustainable Transport: A Sourcebook for Policy-makers in Developing Cities. Module 5g. Edited by Deutsche Gesellschaft fuer Internationale Zusammenarbeit (GIZ) GmbH. Deutsche Gesellschaft fuer Internationale Zusammenarbeit (GIZ) GmbH; German Federal Ministry for Cooperation and Development (BMZ); World Health Organization (WHO). Eschborn (Module 5g).

Duduta, Nicolae; Bishins, Allison (2010): Citywide Transportation Greenhouse Gas Emissions Inventories: A Review of Selected Methodologies. WRI Working Paper. October 2010. Washington DC. Available online at http://pdf.wri.org/working_papers/citywide_transportation_ghg_emissions_inventories.pdf.

Duennelbeil, Frank; Knoerr, Wolfram; Heidt, Christoph; Heuer, Carsten; Lamrecht, Udo (2012): Balancing Transport Greenhouse Gas Emissions in Cities. A Review of Practices in Germany. Final Report. Final Report. GIZ - Deutsche Gesellschaft fuer Internationale Zusammenarbeit GmbH; IFEAU - Institut fuer Energie- und Umweltforschung Heidelberg GmbH. Beijing, China. Available online at http://www.tdm-beijing.org/files/neue%20Publikationen/IFEU_report_FINAL.pdf.

EEA (2016a): EMEP/EEA air pollutant emission inventory guidebook 2016. Technical guidance to prepare national emission inventories. Luxembourg. European Environment Agency. Available online at <http://www.eea.europa.eu/publications/emep-eea-guidebook-2016>.

EEA (2016b): Explaining road transport emissions. A non-technical guide. Luxembourg. Available online at <https://www.eea.europa.eu/publications/explaining-road-transport-emissions>.

EEA (2017): Emissions of air pollutants from transport. Indicator assessment. Available online at <https://www.eea.europa.eu/data-and-maps/indicators/transport-emissions-of-air-pollutants-8/transport-emissions-of-air-pollutants-8>.

Eggleston, Simon; Walsh, Michael; Jacobs, Cindy; Murrells, Tim (2000): Good Practice Guidance and Uncertainty Management in National Greenhouse Gas Inventories. Emissions: Energy, Road Transport. With the assistance of WMO, UNEP. IPCC - International Panel on Climate Change. Available online at https://www.ipcc-nggip.iges.or.jp/public/gp/bgp/2_3_Road_Transport.pdf.

El-Fadel, M.; Hashisho, Z. (2000): Vehicular emissions and air quality assessment in roadway tunnels: The Salim Slam tunnel. In *Transp. Res. Part D Transp. Environ.* 5 (5), pp. 355–372. DOI: 10.1016/S1361-9209(00)00004-3.

Elkafoury, Ahmed; Bady, Mahmoud; Aly, Mohamed Hafez; Negm, Abdelazim M (Eds.) (2013): Emissions Modeling for Road Transportation in Urban Areas: State-of-Art Review. 23rd International Conference on "Environmental Protection is a Must". Alex, May 11-13, 2013.

EMISA (2018): COPERT Australia. Motor vehicle emissions modelling for Australia. Available online at <https://www.emisia.com/utilities/copert-australia/>.

EMISA (2018): COPET SL. COPERT Street Level: from a small street to a big city. Available online at <https://www.emisia.com/utilities/copert-street-level/>.

- Energy Market Authority (2017a): Renewable Energy. Overview. Singapore. Energy Market Authority.
- Energy Market Authority (2017b): Singapore Energy Statistic 2017.
- EPA US (2011): Introduction to MOVES2010. EPA US.
- EPA US (2012): Using MOVES for Estimating State and Local Inventories of On-Road Greenhouse Gas Emissions and Energy Consumption. Final. United States Environmental Protection Agency. Available online at <http://www.epa.gov/oms/stateresources/420b12068.pdf>.
- EPA US (2018a): MOVES and Other Mobile Source Emissions Models.
- EPA US (2018b): MOVES2014, MOVES2014a, and MOVES2014b Technical Guidance: Using MOVES to Prepare Emission Inventories for State Implementation Plans and Transportation Conformity.
- EU (2016): Air quality in Europe. Definition. European Union. Available online at http://www.airqualitynow.eu/pollution_home.php.
- Faiz, Asif; Weaver, Christopher S.; Walsh, Michael P. (1996): Air Pollution from Motor Vehicles. Standard and Technologies for Controlling Emissions. With the assistance of Surhid Gautam, Lit-Mian Chan. The World Bank. Washington D.C.
- Fameli, K. M.; Assimakopoulos, V. D. (2015): Development of a road transport emission inventory for Greece and the Greater Athens Area: Effects of important parameters. In *The Science of the total environment* 505, pp. 770–786. DOI: 10.1016/j.scitotenv.2014.10.015.
- FHWA (2018): Average Annual Miles per Driver by Age Group. With the assistance of U.S. Department of Transportation - Federal Highway Administration. Available online at <https://www.fhwa.dot.gov/ohim/onh00/bar8.htm>.
- Fontes, Tânia; Fernandes, Paulo; Rodrigues, Hugo; Bandeira, Jorge M.; Pereira, Sérgio R.; Khattak, Asad J.; Coelho, Margarida C. (2014): Are HOV/eco-lanes a sustainable option to reducing emissions in a medium-sized European city? In *Transportation Research Part A: Policy and Practice* 63, pp. 93–106. DOI: 10.1016/j.tra.2014.03.002.
- Franco, Vicente; Kousoulidou, Marina; Muntean, Marilena; Ntziachristos, Leonidas; Hausberger, Stefan; Dilara, Panagiota (2013): Road vehicle emission factors development: A review. In *Atmos. Environ.* 70, pp. 84–97. DOI: 10.1016/j.atmosenv.2013.01.006.
- Fredrich, Rainer; Reis, Stefan (2014): Emissions of air pollutants. Stuttgart: Springer Berlin Heidelberg.
- Frey, H. Christopher; Unal, Alper (2002): Use of On-Board Tailpipe Emissions Measurements for Development of Mobile Source Emission Factors. Available online at https://www3.epa.gov/ttnchie1/conference/ei11/mobile/frey_unal.pdf.
- Frey, H. Christopher; Unal, Alper; Roupail, Nagui M.; Colyar, James D. (2003): On-road measurement of vehicle tailpipe emissions using a portable instrument. In *J. Air Waste Manage. Assoc.* 53 (8), pp. 992–1002. DOI: 10.1080/10473289.2003.10466245.
- Frost & Sullivan (2011): Green habits of Singapore drivers.
- Fulper, Carl; Hart, Connie; Warila, Jim; Koupal, John; Kishan, Sandeep; Sabisch, Michael; DeFries, Tim (2011): Development of real-world data for MOVES Development: The Houston Drayage Activity Characterization Study Houston Drayage Study. US EPA; Eastern Research Group.

- Fwa, T. F.; Chua, G. K. (2007): Passenger Car Travel Characteristics in Singapore. Analysis of Changes from 1990 to 2005. In *IATSS Research* 31 (2).
- Gertler, Alan W.; Pierson, William R. (1996): Recent measurements of mobile source emission factors in North American tunnels. In *Sci. Total Environ.* 189-190, pp. 107–113. DOI: 10.1016/0048-9697(96)05197-2.
- Gkatzoflias, Dimitrios; Kouridis, Chariton; Ntziachristos, Leonidas; Samaras, Zissis (2012): COPERT 4 Computer programme to calculate emissions from road transport. User manual (version 9.0). With the assistance of European Environment Agency: EMISIA.
- Goletz, Mirko; Heinrichs, Dirk; Feige, Irene (2016): Mobility trends in cutting-edge cities. Final Report. IFMO - Institute for Mobility Research; DLR - Institute of Transport Research Berlin. Tokyo. Available online at https://www.ifmo.de/files/publications_content/2016/ifmo_2016_mobility_cutting_edge_cities_en.pdf.
- Gruetter, Juerg M. (2007): The CDM in the Transport Sector. Sustainable Transport: A Sourcebook for Policymakers in Developing Countries. Module 5d. Edited by Deutsche Gesellschaft fuer Technische Zusammenarbeit (GTZ) GmbH. Deutsche Gesellschaft fuer Technische Zusammenarbeit (GTZ) GmbH. Eschborn.
- Haan, Peter de; Keller, Mario (2000): Emission factors for passenger cars. Application of instantaneous emission modelling. In *Atmospheric Environment* 34 (27), pp. 4629–4638. DOI: 10.1016/S1352-2310(00)00233-8.
- Haberl, Michael; Fellendorf, Martin; Hausberger, Stefan (Eds.) (2014): Integrating an Emission Minimizing Extension in an adaptive Signal-Control Optimization Algorithm.
- Hallsten, Marcus (2009): Methods for Measurement and Simulation of Fuel Consumption and Emissions on Heavy Duty Vehicles. Master thesis. KTH Industrial Engineering and Management Machine Design, Stockholm, Sweden.
- Hascic, Ivan; Vries, Frans de; Johnstone, Nick; Medhi, Neelakshi (2009): Effects of Environmental Policy on the Type of Innovation: The Case of Automotive Emission-control Technologies. In *OECD Journal Economic Studies* 2009.
- Hausberger, Stefan (2017): PHEM and PEMS Data Use. ERMES Plenary Meeting. TU Graz - Institute of Internal Combustion Engines and Thermodynamics. Zurich, 2017.
- Hausberger, Stefan; Engler, Dieter; Ivanisin, Mario; Rexeis, Martin (2003a): Emission Functions for Heavy Duty Vehicles. Update of the Emission Functions for Heavy Duty Vehicles in the Handbook Emission Factors for Road Traffic. With the assistance of the Federal Environment Agency - Austria. TU Graz - Institute of Internal Combustion Engines and Thermodynamics. Vienna. Available online at <https://www.umweltbundesamt.at/fileadmin/site/publikationen/BE223.pdf>.
- Hausberger, Stefan; Rexeis, Martin; Blassnegger, Juergen; Silberholz, Gerard (2011): Evaluation of fuel efficiency improvements in the Heavy-Duty Vehicle (HDV) sector from improved trailer and tire designs by application of a new test procedure. With the assistance of The International Council on Clean Transportation and Verband der Automobilindustrie. TU Graz - Institute of Internal Combustion Engines and Thermodynamics. Graz. Available online at https://theicct.org/sites/default/files/publications/Final_Report_ICCT_VDA_FINAL2.pdf.
- Hausberger, Stefan; Rodler, Johannes; Sturm, Peter; Rexeis, Martin (2003b): Emission factors for heavy-duty vehicles and validation by tunnel measurements. In *Atmos. Environ.* 37 (37), pp. 5237–5245.

- Hausberger, Stefan; Wiesmayr, Juergen; Bukvarevic, Edim; Tripold, Werner; Brenner, Juergen (2005): Evaporative emissions of vehicles. Final Report for ARTEMIS WP 400. Graz University of Technology (TUG); Fachhochschule Graz (FH).
- Henkel, Andrea; Ambadar, Achmad Zacky; Heidt, Christoph (2014): Supported NAMA. NAMASustainable Urban Transport Programme Indonesia (NAMA SUTRI). Pilot Phase. GIZ - Deutsche Gesellschaft fuer Internationale Zusammenarbeit GmbH. Eschborn. Available online at www.transport-namas.org.
- Hickman, J; Hassel, D; Jourmad, R; Samaras, Z; Sorenson, S (2009): Methodology for Calculating Transport Emission and Energy Consumption. Technical Report V1.0. With assistance of Juhani Jaaskelainen, Eva Boethius. European Commission; the Ministry of Economy, Trade and Industry (METI) of Japan. Tokyo.
- HKEPD (2012): Development of EMFAC-HK using Vehicle Emissions Data Collected by PEMS for the Hong Kong Fleet. Hong Kong Environmental Protection Department.
- HKEPD (2018): EMFAC-HK Vehicle Emission Calculation. Hong Kong Environmental Protection Department.
- Ho, Sze-Hwee; Wong, Yiik-Diew; Chang, Victor Wei-Chung (2014): Developing Singapore Driving Cycle for passenger cars to estimate fuel consumption and vehicular emissions. In *Atmospheric Environment* 97, pp. 353–362. DOI: 10.1016/j.atmosenv.2014.08.042.
- Hofmann, Jana; Guan, Dabo; Chalvatzis, Konstantinos; Huo, Hong (2016): Assessment of electrical vehicles as a successful driver for reducing CO₂ emissions in China. In *Applied Energy* 184, pp. 995–1003. DOI: 10.1016/j.apenergy.2016.06.042.
- Hsu, Yi-Chyun; Tsai, Jiun-Horng; Chen, Huan-Wen; Lin, Wen-Yinn (2001): Tunnel study of on-road vehicle emissions and the photochemical potential in Taiwan. In *Chemosphere* 42 (3), pp. 227–234. DOI: 10.1016/s0045-6535(00)00074-6.
- Huang, Cheng; Tao, Shikang; Lou, Shengrong; Hu, Qingyao; Wang, Hongli; Wang, Qian et al. (2017): Evaluation of emission factors for light-duty gasoline vehicles based on a chassis dynamometer and tunnel studies in Shanghai, China. In *Atmospheric Environment* 169, pp. 193–203. DOI: 10.1016/j.atmosenv.2017.09.020.
- Huang, Wenke; Hu, Mingwei (2018): Estimation of the Impact of Traveler Information Apps on Urban Air Quality Improvement. In *Engineering* 4 (2), pp. 224–229. DOI: 10.1016/j.eng.2018.03.003.
- Hueglin, Christoph; Buchmann, Brigitte; Weber, Rudolf O. (2006): Long-term observation of real-world road traffic emission factors on a motorway in Switzerland. In *Atmospheric Environment* 40 (20), pp. 3696–3709. DOI: 10.1016/j.atmosenv.2006.03.020.
- Hwa, Mei-Yin; Hsieh, Chu-Chin; Wu, Tsung-Cheng; Chang, Len-Fu W. (2002): Real-world vehicle emissions and VOCs profile in the Taipei tunnel located at Taiwan Taipei area. In *Atmospheric Environment* 36 (12), pp. 1993–2002. DOI: 10.1016/S1352-2310(02)00148-6.
- IEA (2016): Energy and Air Pollution. World Energy Outlook 2016 - Special Report. With the assistance of OECD. International Energy Agency.
- IEA (2017a): CO₂ emissions from fuel combustion. Overview. International Energy Agency.
- IEA (2017b): Global EV Outlook 2017. Two million and counting. IEA.
- IEA (2018): CO₂ emissions from fuel combustion. Overview 2018. International Energy Agency.
- IEA (2020): Global EV Outlook 2020.

IMF (2020): Car Ownership. Ownership in 2020. IMF.

Int Panis, L.; Beckx, C.; Broekx, S.; Vlieger, I. de; Schrooten, L.; Degraeuwe, B.; Pelkmans, L. (2011): PM, NO_x and CO₂ emission reductions from speed management policies in Europe. In *Transport Policy* 18 (1), pp. 32–37. DOI: 10.1016/j.tranpol.2010.05.005.

Int Panis, Luc; Broekx, Steven; Liu, Ronghui (2006): Modelling instantaneous traffic emission and the influence of traffic speed limits. In *The Science of the total environment* 371 (1-3), pp. 270–285. DOI: 10.1016/j.scitotenv.2006.08.017.

IPCC (1996): Revised 1996 IPCC Guidelines for National Greenhouse Gas Inventories: Workbook. IPCC.

IPCC (2006): 2006 IPCC Guidelines for National Greenhouse Gas Inventories. Chapter 3: Mobile Combustion. IPCC.

Jamriska, M.; Morawska, L. (2001): A model for determination of motor vehicle emission factors from on-road measurements with a focus on submicrometer particles. In *The Science of the total environment* 264 (3), pp. 241–255.

Jiangxun, L. I. N. (2010): Air Quality Inside an Underground Road Tunnel System. Nanyang Technological University, Singapore. School of Civil and Environmental Engineering; College of Engineering.

Journard, Robert (1999): Methods of estimation of atmospheric emissions from transport. European scientist network and scientific state-of-the-art: Action COST 319 final report. With the assistance of Michel Andre, Robert Coffey, Paul Davison, Vincent Favrel, Benoit Gilson, Ulf Hammarstrom et al. INREST.

Keller, Mario (2007): Assessment and reliability of transport emission models and inventory systems. Road Emission Model – Model Description. With the assistance of the European Commission within The 5th Framework Research Programme. INFRAS.

Keller, Mario; Sjodin, Ake; Gadrat, Marie; McCrae, Ian; Dilara, Panagiota (2009): The Artemis European tools for estimating the transport pollutant emissions.

Ketzel, Matthias; Wåhlin, Peter; Berkowicz, Ruwim; Palmgren, Finn (2003): Particle and trace gas emission factors under urban driving conditions in Copenhagen based on street and roof-level observations. In *Atmospheric Environment* 37 (20), pp. 2735–2749. DOI: 10.1016/S1352-2310(03)00245-0.

Koupal, John; Fulper, Carl; Hart, Connie; Warila, Jim (2012): Development and Use of the MOVES mode, Kansas City Study Dataset. US EPA.

Kousoulidou, Marina; Ntziachristos, Leonidas; Gkeivanidis, S; Samaras, Zissis; Franco, Vicente; Dilara, Panagiota (2009): Validation of the COPERT road emission inventory model with real-use data. Available online at <https://www3.epa.gov/ttnchie1/conference/ei19/session6/dilara.pdf>.

Kwa, Guian Sin (2010): Fire and Life Safety Provisions for a Long Vehicular Tunnel.

Lechowicz, Stan; Jayaratne, Rohan; Morawska, Lidia; Jamriska, Milan (2008): Development of a methodology for the quantification of particle number and gaseous concentrations in a bidirectional bus tunnel and the derivation of emission factors. In *Atmospheric Environment* 42 (35), pp. 8353–8357. DOI: 10.1016/j.atmosenv.2008.07.024.

Lie, T. T.; Prasad, K.; Ding, Ning (2017): The electric vehicle. A review. In *IJEHV* 9 (1), p. 49. DOI: 10.1504/IJEHV.2017.10003709.

Ligterink, Norbert; Lange, Robert de (2008): Development of Realworld Road Traffic Emission Factors using VERSIT+. Building on the tradition in emission modelling. TNO.

- Ligterink, Norbert E.; De lange, Ronald (Eds.) (2009): Refined vehicle and driving-behaviour dependencies in the VERSIT+ emission model. Transport and Air Pollution Conference. Toulouse. Available online at <https://utrechtstad.partijvoordedieren.nl/data/files/2015/12/d96e905df04f8312088abc44dd3513bd.pdf>.
- LTA (2010): Factsheet on Electric Vehicles.
- LTA (2011): Reducing Emissions in the Transport Sector.
- LTA (2012): FELS Brochure.
- LTA (2013a): Land Transport Master Plan 2013. LTMP 2013 Report.
- LTA (2013b): MCE Speed Limit Set at 80km/h and KPE Speed Limit to be Adjusted. Singapore. Land Transport Authority. Available online at <https://www.lta.gov.sg/apps/news/page.aspx?c=2&id=7f48bd67-7a24-4e23-b8a1-7c7e999da154>.
- LTA (2014a): Kallang-Paya Lebar Expressway (KPE). Land Transport Authority, checked on 12/5/2015.
- LTA (2014b): Land Transport Sustainability Update 2014.
- LTA (2015a): Revised Carbon Emissions-Based Vehicle Scheme (CEVS) from 1 July 2015. Singapore. Available online at <https://www.lta.gov.sg/content/ltagov/en/newsroom/2015/2/2/revised-carbon-emissions-based-vehicle-scheme-cevs-from-1-july-2015.html>.
- LTA (2015b): Traffic Flow. Average Speed During Peak Hours. LTA. Singapore. Available online at https://www.lta.gov.sg/content/dam/ltagov/who_we_are/statistics_and_publications/statistics/pdf/Traffic_Flow.pdf.
- LTA (2019a): Annual Vehicle Statistics 2019. Motor Vehicle Population by Vehicle Type. LTA. Available online at https://www.lta.gov.sg/content/dam/ltagov/who_we_are/statistics_and_publications/statistics/pdf/MVP01-1_MVP_by_type.pdf.
- LTA (2019b): Land Transport Master Plan 2040.
- Ma, Chih Ming; Hong, Gui Bing; Chang, Chang Tang (2011): Influence of Traffic Flow Patterns on Air Quality inside the Longest Tunnel in Asia. In *Aerosol Air Qual. Res.* DOI: 10.4209/aaqr.2010.09.0078.
- Ma, Hongrui; Balthasar, Felix; Tait, Nigel; Riera-Palou, Xavier; Harrison, Andrew (2012): A new comparison between the life cycle greenhouse gas emissions of battery electric vehicles and internal combustion vehicles. In *Energy Policy* 44, pp. 160–173. DOI: 10.1016/j.enpol.2012.01.034.
- Madireddy, Madhava; Coensel, Bert de; Can, Arnaud; Degraeuwe, Bart; Beusen, Bart; Vlioger, Ina de; Botteldooren, Dick (2011): Assessment of the impact of speed limit reduction and traffic signal coordination on vehicle emissions using an integrated approach. In *Transportation Research Part D: Transport and Environment* 16 (7), pp. 504–508. DOI: 10.1016/j.trd.2011.06.001.
- Mahmod, Mohamed Morsi; Arem, Bart van (2008): A simulation framework for modelling the impacts of an integrated road-vehicle system on local air quality. Centre for Transport Studies,

University of Twente, the Netherlands. Twente, The Netherlands. Available online at <https://www.utwente.nl/ctw/aida/research/publications/TRAIL2008-Mahmod.pdf>.

Mancilla, Yasmany; Araizaga, Alejandro E.; Mendoza, Alberto (2012): A tunnel study to estimate emission factors from mobile sources in Monterrey, Mexico. In *Journal of the Air & Waste Management Association (1995)* 62 (12), pp. 1431–1442. DOI: 10.1080/10962247.2012.717902.

Meng, Qiang; Qu, Xiaobo (2010): Quantitative Risk Assessment Model for Fire in Road Tunnels with Parameter Uncertainty. In *4th International Workshop on Reliable Engineering Computing*. DOI: 10.3850/978-981-08-5118-7.

Meng, Qiang; Qu, Xiaobo; Yong, Kum Thong; Wong, Yoke Heng (2011): QRA model-based risk impact analysis of traffic flow in urban road tunnels. In *Risk analysis: an official publication of the Society for Risk Analysis* 31 (12), pp. 1872–1882. DOI: 10.1111/j.1539-6924.2011.01624.x.

Mensink, C.; Vlieger, I. de; Nys, J. (2000a): An urban transport emission model for the Antwerp area. In *Atmospheric Environment* 34 (27), pp. 4595–4602. DOI: 10.1016/S1352-2310(00)00215-6.

Meteorological Service Singapore (2018): Climate of Singapore.

Ming, Tok Kian (2009): Air Quality Monitoring of Underground Road Tunnel. Nanyang Technological University, Singapore. School of Civil and Environmental Engineering; College of Engineering.

Misra, Aarshabh; Roorda, Matthew J.; MacLean, Heather L. (2013): An integrated modelling approach to estimate urban traffic emissions. In *Atmospheric Environment* 73, pp. 81–91. DOI: 10.1016/j.atmosenv.2013.03.013.

Moeker, S. (2014): Driving Profile and Energy Demand Analysis for Electrical Vehicle based on GPS Trajectories. Master thesis. Technische Universität München.

Nagpure, Ajay S.; Sharma, Ketki; Gurjar, Bhola R. (2013): Traffic induced emission estimates and trends (2000–2005) in megacity Delhi. In *Urban Climate* 4, pp. 61–73. DOI: 10.1016/j.uclim.2013.04.005.

Nam, Edward K.; Gierczak, Christine A.; Butler, James W. (Eds.) (2003): Comparison of real-world and modelled emissions under conditions of variable driver aggressiveness. 82nd Annual Meeting of the Transportation Research Board. Washington, DC.

Nanni, Alessandro; Pozzi, Cristina; Eriksson, Eva; Lungu, Patricia (2011): Bottom-up Road Traffic Flow and Emission Calculations for the Assessment of Future Traffic Scenarios and Public Transportation Expansion Plans in Bucharest. In *14th Conference on Harmonisation within Atmospheric Dispersion Modelling for Regulatory Purposes*.

Nanni, Alessandro; Velay-Lasry, Fanny; Eriksson, Eva; Soudani, Amina; Abid, Sami (2010): Bottom-up Road Traffic Emission Calculation for the Tunisian Road Network by means of a Traffic Assignment Model. In *13th Conference on Harmonisation within Atmospheric Dispersion Modelling for Regulatory Purposes*.

National Climate Change Secretariat (2012): National Climate Change Strategy 2012. Climate Change and Singapore: Challenges, Opportunities and Partnership. Singapore: National Climate Change Secretariat.

NEA (2014): Singapore's Third National Communication and First Biennial Update Report. Under the United Nations Framework Convention on Climate Change. December 2014. Singapore.

- NEA (2016): Singapore's Second Biennial Update Report. Under the United Nations Framework Convention on Climate Change. 2016. Singapore.
- NEA (2018): Singapore's Fourth National Communication and Third Biennial Update Report. Under the United Nations Framework Convention on Climate Change. 2018. NEA; NCCS. Singapore. Available online at <https://www.nccs.gov.sg/docs/default-source/default-document-library/singapore's-fourth-national-communication-and-third-biennial-update-repo.pdf>.
- NEA; MEWR (2015): Factsheet on more measures to improve Singapore's air quality.
- Nian, Victor; M.P., Hari; Yuan, Jun (2017): The prospects of electric vehicles in cities without policy support. In *Energy Procedia* 143, pp. 33–38. DOI: 10.1016/j.egypro.2017.12.644.
- Noland, Robert B.; Quddus, Mohammed A. (2006): Flow improvements and vehicle emissions. Effects of trip generation and emission control technology. In *Transportation Research Part D: Transport and Environment* 11 (1), pp. 1–14. DOI: 10.1016/j.trd.2005.06.003.
- Notter, Benedikt; Keller, Mario; Althaus, Hans-Joerg; Knoerr, Wolfram; Cox, Brian; Heidt, Christoph et al. (2019): HBEFA 4.1. Development_Report. Bern, Heidelberg.
- Ntziachristos, Leonidas; Samaras, Zissis (2013): EMEP/EEA air pollutant emission inventory. Technical guidance to prepare national emission inventories. Exhaust emissions from road transport. With the assistance of European Environment Agency. 12/2013. Luxembourg: Publications Office (EEA Technical report, 12/2013).
- Odyssee-mure (2021): Sectoral Profile - Transport. Change in distance travelled by car. With assistance of ADEME, Enerdata, Fraunhofer ISI, EASME, EnR. Available online at <https://www.odyssee-mure.eu/publications/efficiency-by-sector/transport/distance-travelled-by-car.html>.
- OECD (2002): Strategies to Reduce Greenhouse Gas Emissions from Road Transport: Analytical Methods. Paris: OECD Publishing.
- Olszewski, Piotr; Fan, Henry S.L; Tan, Yan-Weng (1995): Area-wide traffic speed-flow model for the Singapore CBD. In *Transportation Research Part A: Policy and Practice* 29 (4), pp. 273–281. DOI: 10.1016/0965-8564(94)00033-7.
- Olszewski, Piotr S. (2007): Singapore motorisation restraint and its implications on travel behaviour and urban sustainability. In *Transportation* 34 (3), pp. 319–335. DOI: 10.1007/s11116-007-9115-y.
- OneMonitoring (2021): Certificate of Entitlement (COE) Renewal. Statutory lifespan of vehicles. LTA. Singapore. Available online at <https://onemotoring.lta.gov.sg/content/onemotoring/home/owning/coe-renewal.html>.
- Park, Sangjun; Lee, Jung-beom; Lee, Chungwon (2016): State-of-the-art automobile emissions models and applications in North America and Europe for sustainable transportation. In *KSCE J Civ Eng* 20 (3), pp. 1053–1065. DOI: 10.1007/s12205-016-1682-z.
- Peace, H.; Owen, B.; Raper, D. W. (2004): Comparison of road traffic emission factors and testing by comparison of modelled and measured ambient air quality data. In *The Science of the total environment* 334-335, pp. 385–395. DOI: 10.1016/j.scitotenv.2004.04.058.
- Pierson, William R.; Gertler, Alan W.; Bradow, Ronald L. (1990): Comparison of the SCAQS Tunnel Study with Other On-Road Vehicle Emission Data. In *Journal of the Air & Waste Management Association* 40 (11), pp. 1495–1504. DOI: 10.1080/10473289.1990.10466799.
- Pierson, William R.; Gertler, Alan W.; Robinson, Norman F.; Sagebiel, John C.; Zielinska, Barbara; Bishop, Gary A. et al. (1996): Real-world automotive emissions—Summary of studies

in the Fort McHenry and Tuscarora mountain tunnels. In *Atmospheric Environment* 30 (12), pp. 2233–2256. DOI: 10.1016/1352-2310(95)00276-6.

Reuter, Benjamin; Schönsteiner, Karl; Wagner, Markus; Gleyzes, Daniel; Massier, Tobias; Hamacher, Thomas; Lienkamp, Markus (2013): Life cycle greenhouse gas analysis for automotive applications – A case study for taxis in Singapore. In *International Journal of Smart Grid and Clean Energy Life* 3 (2), pp. 127–134.

Schifter, I.; Díaz, L.; Múgica, V.; López-Salinas, E. (2005): Fuel-based motor vehicle emission inventory for the metropolitan area of Mexico City. In *Atmospheric Environment* 39 (5), pp. 931–940. DOI: 10.1016/j.atmosenv.2004.09.079.

Schmied, Martin (2014): Localising the European Handbook for Emission Factors (HBEFA).

Schmied, Martin; Wuthrich, Philipp; Keller, Mario; Bongardt, Daniel; Sun, Chengyang (2013): Localising the Handbook of Emission Factors for Road Transport to Chinese Cities Approach to adapt HBEFA to Chinese cities.

Seng Tat Chua and Masaru Nakano (2013): Design of a Taxation System to Promote Electric Vehicles in Singapore.

Seo, Jigu; Kim, Hyungjun; Park, Sungwook (2018): Estimation of CO₂ emissions from heavy-duty vehicles in Korea and potential for reduction based on scenario analysis. In *The Science of the total environment* 636, pp. 1192–1201. DOI: 10.1016/j.scitotenv.2018.04.269.

Sims, R.; Schaeffer, R.; Creutzig, F.; Cruz-Núñez, X.; D'Agosto, M.; Dimitriu, D. et al. (2014): Transport. In: *Climate Change 2014: Mitigation of Climate Change. Contribution of Working Group III to the Fifth Assessment Report of the Intergovernmental Panel on Climate Change* [Edenhofer, O., R. Pichs-Madruga, Y. Sokona, E. Farahani, S. Kadner, K. Seyboth, A. Adler, IPCC. Cambridge University Press, Cambridge, United Kingdom and New York, NY, USA. Available online at https://www.ipcc.ch/site/assets/uploads/2018/02/ipcc_wg3_ar5_chapter8.pdf.

Singapore in Figures 2019.

NCCS (2016): Singapore's Emissions Profile. Singapore.

Smit, Robin (2006): An Examination of Congestion in Road Traffic Emission Models and Their Application to Urban Network. Dissertation. Griffith University. School of Environmental Planning; Faculty of Environmental Sciences,

Smit, Robin; Brown, A. L.; Chan, Y. C. (2008): Do air pollution emissions and fuel consumption models for roadways include the effects of congestion in the roadway traffic flow? In *Environmental Modelling & Software* 23 (10-11), pp. 1262–1270. DOI: 10.1016/j.envsoft.2008.03.001.

Smit, Robin; Dia, Husain; Morawska, Lidia (Eds.) (2009): Traffic-related air pollution and internal combustion engines. Road traffic emission and fuel consumption modelling: trends, new developments and future challenges. Chapter 2. New York: Nova Science Publishers (Air, water and soil science and technology series).

Smit, Robin; Keller, Mario; Ning, Zhi; Ntziachristos, Leonidas (2014): Literature review report of European Vehicle Emission Models. EMISIA.

Smit, Robin; McBroom, James (2009a): Development of a new high-resolution traffic emissions and fuel consumption model for Australia and New Zealand. Data quality considerations. In *Air Quality and Climate Change* Volume 43 No.2 May 2009.

Smit, Robin; McBroom, James (2009b): Use of Overseas Emission Models to predict Traffic Emissions in Urban Areas. In *Road and Transport Research* Vol 18 (No.3).

- Smit, Robin; Ntziachristos, Leonidas (Eds.) (2012): COPERT Australia: Developing Improved Average Speed Vehicle Emission Algorithms for the Australian Fleet. 19th International Transport and Air Pollution Conference, Thessaloniki, Greece, 26-27 November 2012.
- Smit, Robin; Ntziachristos, Leonidas; Boulter, Paul (2010): Validation of road vehicle and traffic emission models – A review and meta-analysis. In *Atmospheric Environment* 44 (25), pp. 2943–2953. DOI: 10.1016/j.atmosenv.2010.05.022.
- Smit, Robin; Ntziachristos, Leonidas (Eds.) (2013): COPERT Australia: a new software to estimate vehicle emissions in Australia. Australasian Transport Research Forum. Brisbane, Australia, 2 - 4 October 2013.
- Smit, Robin; Smokers, Richard; Rabé, Elke (2007): A new modelling approach for road traffic emissions. VERSIT+. In *Transportation Research Part D: Transport and Environment* 12 (6), pp. 414–422. DOI: 10.1016/j.trd.2007.05.001.
- Smit, Robin; Smokers, Richard; Schoen, Eric; Hensema, Amber (2006): A New Modelling Approach for Road Traffic Emissions: VERSIT+ LD. Background and Methodology. TNO.
- Smith, William J. (2010): Can EV (electric vehicles) address Ireland's CO₂ emissions from transport? In *Energy* 35 (12), pp. 4514–4521. DOI: 10.1016/j.energy.2010.07.029.
- Smokers, Richard; Rensma, Karen (2006): Geographically specific transport emission inventories. Review of feasibility for road and rail transport. Delft: CE Delft.
- Soltic, Patrik; Weilenmann, Martin (2003): NO₂/NO emissions of gasoline passenger cars and light-duty trucks with Euro-2 emission standard. In *Atmospheric Environment* 37 (37), pp. 5207–5216. DOI: 10.1016/j.atmosenv.2003.05.003.
- Soylu, Seref (2007): Estimation of Turkish road transport emissions. In *Energy Policy* 35 (8), pp. 4088–4094. DOI: 10.1016/j.enpol.2007.02.015.
- Spence, Angela; Turksma, Siebe; Schelling, Ab; Benz, Thomas; Medevielle, Jean-Pierre; Mc Crae, Ian (2009): Methodologies for assessing the impact of ITS applications on CO₂ emissions. Technical Report V1.0. With assistance of Juhani Jaaskelainen, Eva Boethius.
- Staehelin, Johannes; Schlaepfer, Kurt; Buergin, Toni; Steinemann, Urs; Brunner, Dominik; Bzümle, Martin et al. (1994): Emission factors from road traffic from a tunnel study (Gubrist tunnel, Switzerland). Part I: Concept and first results 169, pp. 141–147.
- Stathopoulos, Fotis; Noland, Robert (2003): Induced Travel and Emissions from Traffic Flow Improvement Projects 1842, pp. 57–63. DOI: 10.3141/1842-07.
- Stratas Advisors (2018): Singapore to Further Tighten Gasoline and Diesel Specifications from July 1, 2019.
- Sturm, Peter; Rodler, Johannes; Lechner, Bernhard (2001): Validation of emission factors for road vehicles based on street tunnel measurements. In *Int. J. Veh. Des.*
- Sucharov, Lance; Brebbia, C. A. (2000): Urban transport VI. Urban transport and the environment for the 21st century/ editors L. Sucharov, C.A. Brebbia. Southampton: WIT Press (Advances in transport, 1462-608X, v. 6).
- Sun, Chengyang; Schmied, Martin; Bongardt, Daniel; Wuethrich, Phillipp; Eichhorst, Urda (2015): Modelling Energy Consumption and GHG Emissions of Road Transport in China. Technical Paper on GIZ CRTEM/HBEFA-China Model. Edited by Deutsche Gesellschaft fuer Internationale Zusammenarbeit (GIZ) GmbH. Deutsche Gesellschaft fuer Internationale Zusammenarbeit (GIZ) GmbH; German Federal Ministry for Cooperation and Development

(BMZ); World Health Organization (WHO). Eschborn (Technical Paper on GIZ CRTEM/HBEFA-China Model).

Sundvor, Ingrid; Balaguer, Nuria Castell; Guerreiro, Cristina; Viana, Mar; Querol, Xavier; Reche, Cristina et al. (2012): Road traffic's contribution to air quality in European cities. ETC/ACM Technical Paper 2012/14. ETC/ACM. Bilthoven, Netherland. Available online at https://www.eionet.europa.eu/etcs/etc-atni/products/etc-atni-reports/etcacm_tp_2012_14_traffic_contribution_city_aq/@_@download/file/ETCACM_TP_2012_14_traffic_contribution_city_aq.pdf.

Tan, Sok Huang; Roth, Matthias; Velasco, Erik (2017): Particle exposure and inhaled dose during commuting in Singapore. In *Atmospheric Environment* 170, pp. 245–258. DOI: 10.1016/j.atmosenv.2017.09.056.

Tanaka, Katsumasa; Lund, Marianne T.; Aamaas, Borgar; Berntsen, Terje (2018): Climate effects of non-compliant Volkswagen diesel cars. In *Environ. Res. Lett.* 13 (4), p. 44020. DOI: 10.1088/1748-9326/aab18c.

Teoh, Tharsis; Kunze, Oliver; Teo, Chee-Chong; Wong, Yiik Diew (2018): Decarbonisation of Urban Freight Transport Using Electric Vehicles and Opportunity Charging.

Thorpe, Alistair J.; Harrison, Roy M.; Boulter, Paul G.; McCrae, Ian S. (2007): Estimation of particle resuspension source strength on a major London Road. In *Atmospheric Environment* 41 (37), pp. 8007–8020. DOI: 10.1016/j.atmosenv.2007.07.006.

Timmers, Victor R.J.H.; Achten, Peter A.J. (2016): Non-exhaust PM emissions from electric vehicles. In *Atmospheric Environment* 134, pp. 10–17. DOI: 10.1016/j.atmosenv.2016.03.017.

Trachet, B.; Madireddy, M. (2010): The influence of traffic management on emissions. Literature study of existing emission models and initial tests with micro traffic simulation. Steunpunt Mobiliteit & Openbare Werken.

Transport and Environment (2015): Five facts about diesel the car industry would rather not tell you. Transport & Environment. Available online at https://www.transportenvironment.org/sites/te/files/publications/2015_09_Five_facts_about_diesel_FINAL.pdf.

Treiber, Martin; Kesting, Arne (2013): Traffic Flow Dynamics. Data, Models and Simulation. Berlin, Heidelberg: Springer. Available online at <http://dx.doi.org/10.1007/978-3-642-32460-4>.

TRIP: Methodology for Calculating Transport Emissions and Energy Consumption. With assistance of The European Commission's Directorate General for Mobility and Transport. The Transport Research and Innovation Portal (TRIP). Available online at <http://www.transport-research.info/project/methodology-calculating-transport-emissions-and-energy-consumption>.

U.S. EPA (2021): Overview of EPA's MOtor Vehicle Emission Simulator (MOVES3). U.S. EPA. Available online at <https://www.epa.gov/sites/production/files/2021-03/documents/420r21004.pdf>.

UN (2014): World urbanization prospects. The 2014 revision: highlights. New York.

UNEP (2015): Air Quality Policies. Singapore. Available online at <http://www.unep.org/transport/airquality/Singapore.pdf>.

US EPA (2015): MOVES2014 Technical Guidance: Using MOVES to Prepare Emission Inventories for State Implementation Plans and Transportation Conformity. Using MOVES to Prepare Emission Inventories for State Implementation Plans and Transportation Conformity. United States Environmental Protection Agency. Available online at <http://www.epa.gov/otaq/models/moves/documents/420b15007.pdf>.

- Vallamsundar, Suriya; Lin, Jane (2011): Overview of U.S EPA New Generation Emission Model: MOVES. In *ACEEE Int. J. on Transportation and Urban Development* 01.
- Van der Meer, J. (2007): Cruising towards better air quality: The influence of Dynamic Traffic Management on vehicle emissions through driving profile improvements. Master theses. Civil Engineering and Geosciences.
- Varga, Bogdan Ovidiu (2013): Electric vehicles, primary energy sources and CO₂ emissions. Romanian case study. In *Energy* 49, pp. 61–70. DOI: 10.1016/j.energy.2012.10.036.
- Velasco, Erik; Tan, Sok Huang (2016): Particles exposure while sitting at bus stops of hot and humid Singapore. In *Atmospheric Environment* 142, pp. 251–263. DOI: 10.1016/j.atmosenv.2016.07.054.
- Vestreng, V.; Ntziachristos, L.; Semb, A.; Reis, S.; Isaksen, I. S. A.; Tarrason, L. (2009): Evolution of NO_x emissions in Europe with focus on road transport control measures. In *Atmos. Chem. Phys.*
- Wagner, Markus; Schoensteiner, Karl; Hamacher, Thomas (2012): Impacts of Photovoltaics and Electromobility on the Singaporean Energy Sector. In *Energy Procedia* 25, pp. 126–134. DOI: 10.1016/j.egypro.2012.07.017.
- Waldron, Christina Davies; Harnish, John; Lucon, Oswaldo; Mckibbin, R. Scott; Sharon, B. Saile; Wagner, Fabian; Walsh, Michael P (2006): 2006 IPCC Guidelines for National Greenhouse Gas Inventories. Volume 2 - Energy. Chapter 3 - Mobile Combustion. Volume 2.
- Wang, H.; McGlinchy, I. (Eds.) (2009a): Review of vehicle emission modelling and the issues for New Zealand. 32nd Australasian Transport Research Forum. Auckland, 29 September – 1 October 2009.
- Wang, H.; McGlinchy, I. (2009b): Review of vehicle emission modelling and the issues for New Zealand. Presentation slides.
- Wei, W.; Cheah, L. (2014): Singapore Road Vehicle Fleet Evolution.
- WHO (2015): Health and Sustainable Development. Available online at <http://www.who.int/sustainable-development/transport/health-risks/air-pollution/en/>.
- WHO (2018): Ambient (outdoor) air pollution. Available online at [https://www.who.int/news-room/fact-sheets/detail/ambient-\(outdoor\)-air-quality-and-health](https://www.who.int/news-room/fact-sheets/detail/ambient-(outdoor)-air-quality-and-health).
- Wismans, Luc; van Berkum, Eric; Bliemer, Michiel (2011): Modelling Externalities using Dynamic Traffic Assignment Models. A Review. In *Transport Reviews* 31 (4), pp. 521–545. DOI: 10.1080/01441647.2010.544856.
- Wong, Siew Chee; Yuanita, Vivi; Isa, Mohammed Fadzil; Yong, Kum Thong (Eds.) (2010): Review of Road Tunnel Standards - The Safety Implications on Urban Road Tunnels in Singapore. Tunnel Safety and Ventilation. Graz. Systems Assurance & Integration Division, Land Transport Authority of Singapore.
- World Bank (2015a): Road sector diesel fuel consumption (kt of oil equivalent). World Bank, World Development Indicators and EconStatsTM. Available online at http://www.econstats.com/wdi/wdiv_572.htm.
- World Bank (2015b): Road sector gasoline fuel consumption (kt of oil equivalent). World Bank, World Development Indicators and EconStatsTM. Available online at http://www.econstats.com/wdi/wdiv_581.htm.
- Xie, Yuanchang; Chowdhury, Mashrur; Bhavsar, Parth; Zhou, Yan (2012): An integrated modelling approach for facilitating emission estimations of alternative fueled vehicles. In

Transportation Research Part D: Transport and Environment 17 (1), pp. 15–20. DOI: 10.1016/j.trd.2011.08.009.

Xu, Min; Meng, Qiang; Liu, Yisi (Eds.) (2017): Public's Perception of Adopting Electric Vehicles: A Case Study of Singapore.

Xue, Feng; Gwee, Evan (2017): Electric Vehicle Development in Singapore and Technical Considerations for Charging Infrastructure. In *Energy Procedia* 143, pp. 3–14. DOI: 10.1016/j.egypro.2017.12.640.

Yamamoto, Sakae; Mori, Hirohiko (Eds.) (2019): Human Interface and the Management of Information. Visual Information and Knowledge Management. Thematic Area, HIMI 2019, Held as Part of the 21st HCI International Conference, HCII 2019, Orlando, FL, USA, July 26-31, 2019, Proceedings, Part I. 1st ed. 2019. Cham: Springer.

Yang, Ang Jian (2014): Underground Road Tunnel – Air Quality and Associated Environmental / Health Impact. Bachelor thesis. Nanyang Technological University, Singapore. School of Civil and Environmental Engineering; College of Engineering.

Yong, Taeseok; Park, Chankook (2017): A qualitative comparative analysis on factors affecting the deployment of electric vehicles. In *Energy Procedia* 128, pp. 497–503. DOI: 10.1016/j.egypro.2017.09.066.

Acronyms and abbreviations

ARF	Additional registration fee
ARTEMIS	Assessment of Transport Emission Modelling and Inventory Systems
AS	Average speed
AYE	Ayer Rajah Expressway
B	Bus
BaU	Business as Usual
BEV	Battery electric vehicle
BRT	Bus rapid transit
CARB	California Air Research Board
CBD	Central business district
CCTV	Closed-circuit televisions
CDM	Clean Development Mechanism
CEVS	Carbon emissions-based vehicle scheme
CH ₄	Methane
CLRTAP	Convention on Long-range Transboundary Air Pollution
CNG	Compressed natural gas
CO	Carbon monoxide
CO ₂	Carbon dioxide
COE	Certificate of entitlement
COHb	Carboxyhaemoglobin
COPERT	Computer Programme to calculate Emissions from Road Transport
EC	Energy consumption
ECE	The United Nations Economic Commission for Europe
EEA	European Environment Agency
EIA	Environmental impact assessment
EMEP	The European Monitoring and Evaluation Programme
EMFAC	California Air Resources Board Emission Factor
EF	Emission factor
EPA	Environmental Protection Agency
ERP	Electronic road pricing
ETS	Early turnover scheme
EU	The European Union
EV	Electric vehicle
EVTP	Electric vehicle task force
FC	Fuel Consumption
FELS	Fuel economy labelling scheme
FTP75	The FTP-75 (Federal Test Procedure)
GEF	Grid emission factor
GHG	Greenhouse gas
GIS	Geographical information system
GPS	Global positioning system
GST	Goods and service tax
GVR	Green vehicle rebate
HBEFA	Handbook Emission Factors for Road Transport

HC	Hydrocarbons
HDV	Heavy-duty Vehicle
HEV	Hybrid electric vehicle
ICE	Internal combustion engine
INDC	Intended Nationally Determined Contribution
IPCC	Intergovernmental Panel on Climate Change
ITS	Intelligent transportation system
JRC	The Joint Research Centre
KPE	Kallang Paya-Lebar Expressway
LDV	Light-duty vehicle
LNG	Liquid natural gas
LTA	Land Transport Authority
MC	Motorcycle
MCE	Marina Coastal Expressway
MEET	Methodology for Calculating Transport Emissions and Energy
MEWR	Ministry of the Environment and Water Resources
MOVES	Multi-scale Motor Vehicle Emission Simulator Model
MRT	Mass rapid transit
NAEI	UK National Atmospheric Emission Inventory
NAMA	National Appropriate Mitigation Actions
NCCS	National Climate Change Secretariat of Singapore
NEA	National Environment Agency of Singapore
NMHC	Non-methane hydrocarbon
NMIM	The National Mobile Inventory Model
NMOG	Non-methane organic gasses
NO _x	Nitrogen oxides
OBD	On-board diagnostics
OC	Organic carbons
OECD	The Organization for Economic Co-operation and Development
OMDG	Operating Mode Distribution Generator
OMV	Open market value
OPC	Off-peak car
PC	Passenger car
PEMS	Portable emissions measurement systems
PHC	Private hire cars
PHEM	Passenger Car and Heavy-Duty Emission Model
PHEV	Plug-in hybrid electric vehicle
PM	Particulate matter
PMD	Personal mobile device
R&D	Research and development
RPA	Relative positive acceleration
RVP	Reid vapour pressure
SBDG	Source Bin Distribution Generator
SEA	Strategic environmental assessment
SIP	State implementation plan
SO ₂	Sulphur dioxide

SUTRI	Sustainable Urban Transport in Indonesia
TAG	Total Activity Generator
TAQMMS	Automated telemetric air quality monitoring and management system
THC	Total hydrocarbon
TOC	Total organic carbon
TREMOT	Transport Emission Model
UHCs	Unburnt hydrocarbon
UNFCCC	United Nations Framework Convention on Climate Change
US	The United States
VGR	Vehicle growth rate
VKT / VMT	Vehicle kilometre travelled / Vehicle mileage travelled
VOCs	Volatile organic compounds
VQS	Vehicle quota system
VSP	Vehicle specific power
VTM	Vehicle travelled miles

Appendix

List of Appendix

Appendix A: A summary of the fiscal and non-fiscal measures in Singapore that have been implemented to manage the vehicle population growth	182
Appendix B: Singapore road transport vehicle population by year. Source: LTA Statistic (2004-2019)	182
Appendix C: VKT of Singapore's vehicles from 2004 and 2019. Source: Analysed from LTA Statistic (2004-2019)	183

Appendix A: A summary of the fiscal and non-fiscal measures in Singapore that have been implemented to manage the vehicle population growth

Registration Fee	A Registration Fee covers the costs of registering a vehicle in Singapore. It is collected upon registration of the vehicle.
Additional Registration Fee (ARF)	The Additional Registration Fee (ARF) is a tax imposed upon the registration of a vehicle. It is calculated based on a percentage of the Open Market Value (OMV) of the vehicle.
Preferable Additional Registration Fee (PARF)	The Preferential Additional Registration Fee (PARF) benefit is granted to a vehicle owner who de-registers his car by scrap or export before the car reaches ten years old. This fee ensures a relatively young and roadworthy fleet for smooth-flowing traffic.
Excessive Duty	Excise Duty is a tax imposed and collected by Singapore Customs. Like the ARF, the Excise Duty is also calculated based on a percentage of the OMV of the vehicle, 20% of OMV.
Road Taxes	Levied progressively based on engine capacity as follows Additional road tax surcharge for vehicles over ten years
Vehicle Quota System (VQS)	Implemented since 1 May 1990 the scheme requires buyers of all new vehicles other than public buses and school buses to take part in a public tender to get a license to buy a fixed number of vehicles.
Special Tax	A Special Tax is levied on diesel cars and is payable in addition to the vehicle's Road Tax. The quantum of the Special Tax for diesel cars considers the particulate matter (PM) emissions. A petrol duty is imposed to encourage fuel conservation and discourage excessive use of vehicles that may contribute to congestion and pollution. However, there is currently no equivalent duty imposed on diesel.
Carbon Emissions-Based Vehicle Scheme (CEVS)	To further encourage vehicle buyers to shift to low-carbon emission models, rebates and surcharges will be increased for very low and high-carbon emission vehicles.
Off-Peak Car (OPC)	Off-peak cars, or red plates, were introduced in 1994 to help cut the rising costs of motoring and make it more affordable to own a car. These cars cannot be driven from 7 am to 7 pm on weekdays, among other restrictions
Electronic Road Pricing (ERP)	ERP is a traffic management tool to alleviate localised road traffic congestion (since 1998).

Appendix B: Singapore road transport vehicle population by year. Source: LTA Statistic (2004-2019)

		Total	PC	PHC	Taxi	Coach	Bus	MC	LDV	HDV
Share in 2004		100%	57.4%	1.0%	2.9%	1.30%	0.51%	19.1%	12.7%	5.1%
2004	2.3%	713,233	409,648	7,455	20,407	9,274	3,618	136,122	90,579	36,130
2005	3.8%	740,578	430,438	7,756	22,383	9,621	3,599	138,588	91,588	36,605
2006	5.9%	784,195	463,073	9,235	23,334	10,046	3,785	141,881	93,244	39,597
2007	6.5%	835,409	503,631	11,054	24,446	10,431	3,761	143,482	97,019	41,585
2008	5.1%	877,985	538,064	12,391	24,300	11,122	3,854	145,288	98,986	43,980
2009	3.5%	908,488	564,225	12,763	24,702	11,614	4,045	146,337	99,956	44,846
2010	2.2%	928,089	581,838	13,347	26,073	11,955	3,981	147,282	98,569	45,044
2011	1.1%	938,264	589,804	13,919	27,051	12,540	4,112	145,680	99,112	46,046
2012	1.3%	950,880	602,708	14,862	28,210	12,556	4,212	143,286	98,058	46,988
2013	0.4%	954,614	604,949	16,396	27,695	12,513	4,552	144,307	95,483	48,719
2014	-0.3%	951,365	597,762	18,847	28,736	12,353	4,756	144,404	95,599	48,908
2015	-1.7%	935,561	572,942	29,369	28,259	12,620	5,120	143,279	97,013	46,959
2016	-0.2%	933,534	549,921	51,336	27,534	12,868	5,470	142,439	98,742	45,224
2017	0.5%	938,371	544,173	68,083	23,140	13,149	5,665	141,304	97,696	45,161
2018	-0.5%	933,230	548,972	66,480	20,581	13,171	5,776	136,842	96,968	44,440
2019	1.8%	949,826	553,455	77,141	18,542	13,463	5,863	140,398	96,758	44,206
∅	2.0%									
Share in 2019		100%	58.3%	8.1%	2.0%	1.4%	0.6%	14.8%	10.2%	4.7%

^aAGR is the annual growth rate

Appendix C: VKT of Singapore's vehicles from 2004 and 2019. Source: Analysed from LTA Statistic (2004-2019)

	PC	PHC (estimated)	Taxi	Coach	Bus	MC	LDV	HDV
2004	20,298	30,447	133,696	45,789	82,664.7	13,744	29,374	39,158
2005	20,603	30,905	133,696	46,269	83,385.1	13,711	29,248	38,768
2006	21,100	33,760	133,696	45,400	80,328.9	13,700	29,300	40,400
2007	20,800	33,280	131,694	46,800	81,928.5	13,800	28,100	42,400
2008	19,700	33,490	120,502	44,000	78,303.6	13,300	27,900	42,000
2009	19,600	33,320	111,503	47,400	76,645.5	13,200	28,000	41,200
2010	19,100	34,380	115,163	48,400	76,988.3	13,500	28,500	40,900
2011	19,000	34,200	114,185	50,000	72,671.6	13,400	29,900	44,100
2012	18,200	34,580	109,937	54,300	70,842.2	13,300	29,700	39,400
2013	17,800	35,600	124,569	54,100	68,686.1	12,900	30,000	38,100
2014	17,500	35,956	140,962	53,400	69,201.1	12,800	30,500	39,000
2015	17,300	36,316	143,272	52,100	67,592.6	12,800	30,600	42,900
2016	16,700	36,679	134,392	49,400	67,592.6	13,200	30,600	42,800
2017	16,700	37,046	130,240	52,400	66,363.6	13,200	29,700	40,100
2018	17,500	37,416	118,250	44,800	66,363.6	13,000	29,500	39,500