

# Working principle of new multi-chamber rotary compressor

M Lin<sup>1,4</sup>, Y D Lim<sup>2,5</sup> and K T Ooi<sup>3,6</sup>

<sup>1,2,3</sup> School of Mechanical and Aerospace Engineering, Nanyang Technological University, 50 Nanyang Avenue, Singapore 639798

<sup>4</sup> ylin021@e.ntu.edu.sg, <sup>5</sup> ylim046@e.ntu.edu.sg, <sup>6</sup> mktooi@ntu.edu.sg

**Abstract** – A new multi-chamber rotary compressor (MCRC) is introduced in this paper. This new compressor is designed for compactness and energy efficient, with potential applications in refrigeration systems. In this paper, the design of the new compressor will be presented. Various components and their functions together with the overall advantages will be shown and discussed. In its basic form, it is a rotary compressor with two chambers working simultaneously to increase its output by maximizing the available working space and hence reduces material usage. The basic working principles will also be discussed and its advantages will be presented in comparison with other existing rotary compressors.

Keywords - compressor; efficiency; refrigeration; thermodynamics

## 1. Introduction

In the past three decades, depletion of ozone layer and global warming are the environmental issues that world leaders tried to overcome. To overcome the environmental issues, Montreal Protocol [1] aimed at phasing out the substances causing ozone depletion was signed and it was followed by Kyoto Protocol [2] and Paris Agreement [3], to tackle the climate change issues.

The applications of cooling and heating systems worldwide result in significant usage of energy. It is estimated that about 32% [4] of the world energy demanded has been used in cooling and heating in the building sector alone. The use of cooling and heating systems is expected to rise. Thus, there is a need to increase the energy efficiency of the cooling and heating systems. Since the compressor is used in almost all these systems, and it is also the device which consumes the most energy in the systems, it is therefore the objective of this paper to introduce a new compressor which is more compact, and hence saving materials usage and at the same time, it is energy efficient.

## 2. Literature review

In this section, articles relevant to the design and development of the new multi-chamber rotary compressor (MCRC) are reviewed.



### 2.1. Rolling piston compressor

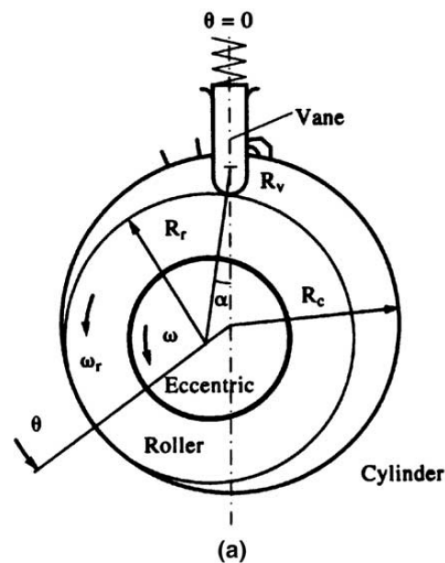

**Figure 1.** Schematic model of rolling piston compressor [8]

Figure 1 shows a schematic view of a rolling piston compressor [8]. It consists of a rolling piston which is the roller in Figure 1, a cylinder which holds the roller and a vane-spring mechanism. When the shaft operates, the rolling piston that is mounted on the shaft eccentrically rotates in the cylinder, rolling against the inner wall of the cylinder [9]. During the rotation of the rolling piston, there will be space formed between the vane, the cylinder and the rolling piston. The changes in the size of the space results in suction, compression and discharge of the working fluid.

Yanagisawa and Shimizu [9] examined various frictional losses with varying loading force and sliding velocity in the rolling piston type compressor and found that the vane tip frictional loss is greatly influenced by the changes in sliding velocity on the vane tip. Moreover, it was observed that the tangential force at contact point has a great influence on the vane side frictional loss. Liu and Kosco investigated [10] rolling piston compressor with different tilt angle of vane. It was observed that the vane tip normal force has a minimum value at a certain positive angle, with the vane friction loss remains unchanged. This indicates that a tilted vane only enhances durability and reliability of the vane and piston, whereas the mechanical efficiency is not improved.

Bae et al. [11] introduced the preventing techniques of vane jumping and visualized the vane jumping using image processing technique. Light vane and long spring were suggested to prevent vane jumping. Vane jumping causes loud noise and most importantly, leakage between the suction chamber and compression chamber. The possible leakage paths are found at the contact point between piston and the cylinder, gap due to vane jumping, clearances between upper and lower faces of the rolling piston compressor and clearance between the vane and the vane slot [12-14]. Out of these, leakage through the clearance between piston and bearing and between the vane and the vane slot have the most significant effect on input power [15].

Although rolling piston compressor is currently the most widely used compressor, it can be further improved by optimizing the design dimensions or modify from the current design such as utilizing the volume occupied by the rotor in a conventional rolling piston compressor.

## 2.2. Swing compressor

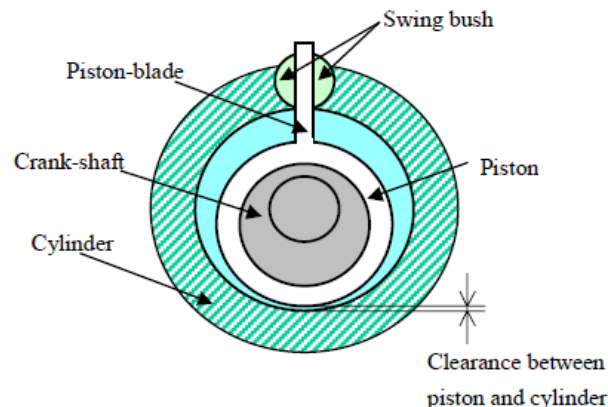

**Figure 2.** Schematic view of a swing compressor [16]

A schematic view of swing compressor is shown in Figure 2. The design of a swing compressor is basically similar to a rolling piston type, but the rotary structure is changed to swing structure to improve the durability and the lubricating ability [17]. Masuda et al. [17] performed theoretical simulation and experimental investigation to compare rotary compressor and swing compressor. The total efficiency of latter was found 5~9% higher than the rotary type in middle to low speed and 2% higher in high-speed range. Furusho et al. [18] conducted numerical and experimental study on swing compressor characteristic and concluded that the total efficiency is higher than rotary type in capacity range of 15.5kW. The study also stated that different refrigerants should be used in different capacity range to maximize the efficiency of swing compressor. In addition, Hu et al. [19] introduces swing vane compressor (SVC) and reported that the mechanical efficiency in SVC is higher than sliding vane compressor under same rotation speed while the total frictional loss in SVC is 65% less than sliding vane compressor.

In conclusion, from the literatures review, the design of the compressor tends toward common features as following:

- Fewer components and simpler geometries for easier fabrication and lesser production cost.
- More compact in size to allow it for more applications other than air-conditioning, such as in electric vehicles.
- Fewer moving parts to reduce the frictional loss.
- Smoother and quieter operation.

Rotary type compressors are widely used in the current refrigeration systems. With the assistance of the computational power, a simpler geometry, smaller size, lower frictional loss and lower noise level compressor can be designed and developed.

## 3. Conceptual model of Multi-Chamber Rotary Compressor (MCRC)

The conceptual model of MCRC, which includes the main components, assembly and working principle are introduced.

### 3.1 Components of MCRPC

#### 3.1.1. Outer cylinder

The major components of MCRC comprise an outer cylinder with the split bush attached to it, a hollow cylinder that is connected to a vane and an inner cylinder. The outermost part of MCRC is the outer

cylinder, where the other components of MCRC are contained within it. The inner wall of the outer cylinder is in contact with the hollow cylinder. Split bush is placed in the expanded slot on the outer cylinder to allow the sliding motion of the vane between the slot of the split bush as shown in Figure 11 and Figure 4. The slot is expanded to avoid a direct contact of the vane with the outer cylinder, to reduce the frictional loss.

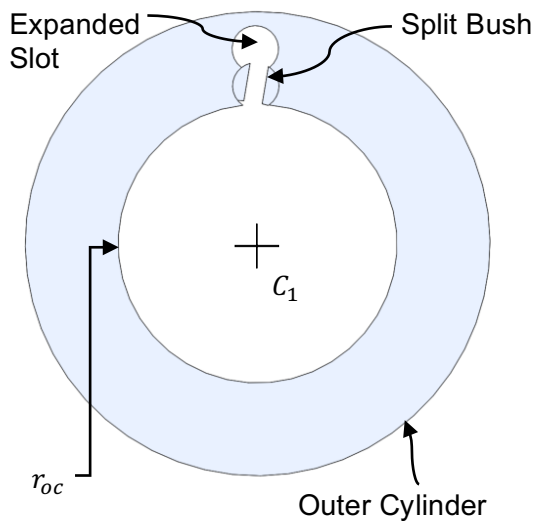

**Figure 3.** Top sectional view of split bush and outer cylinder of MCRC

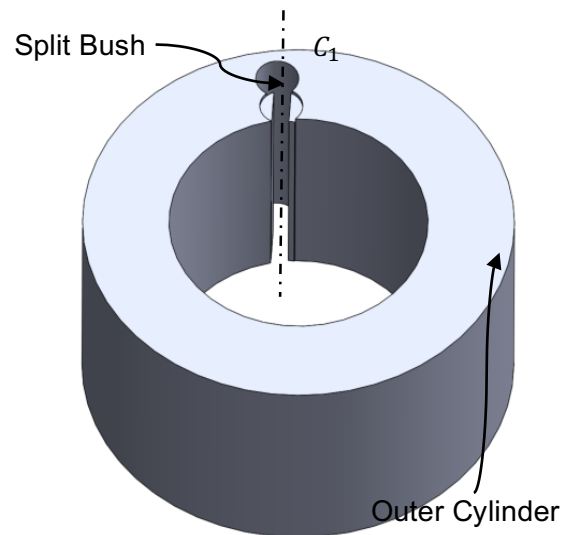

**Figure 4.** Isometric view of split bush and outer cylinder of MCRC

### 3.1.2. Hollow cylinder

The outer surface of the hollow cylinder as shown in Figure 5 and Figure 6 is radially attached to a vane named vane 1 such that it is a one-piece component. The inner space of the hollow cylinder can be separated into inner compressor chamber and slot for cam-shaft. The geometry constraint of the hollow cylinder is its outer surface must get in contact with the inner surface of the outer cylinder, while maintaining a contact between the inner surface of the hollow cylinder and the surface of the inner cylinder. Due to this geometry constraint, the geometrical dimensions such as the thickness of the of the hollow cylinder ( $t_h$ ) must be carefully defined to ensure smooth operations. In addition, the width of vane 1 is determined by the space between the split bush at the outer cylinder. The gap between the vane and split bush must be carefully defined to refrain from having too much direct contact which will result in high frictional loss or low contact level which will cause the jumping of the vane.

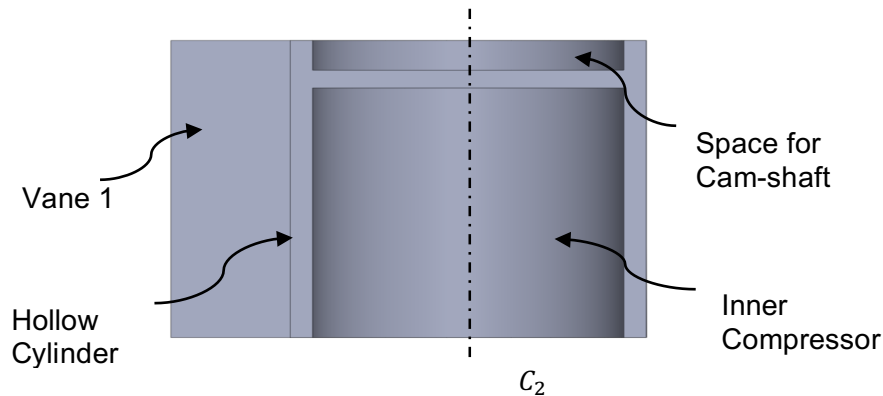

**Figure 5.** Cross-sectional side view of hollow cylinder and vane 1

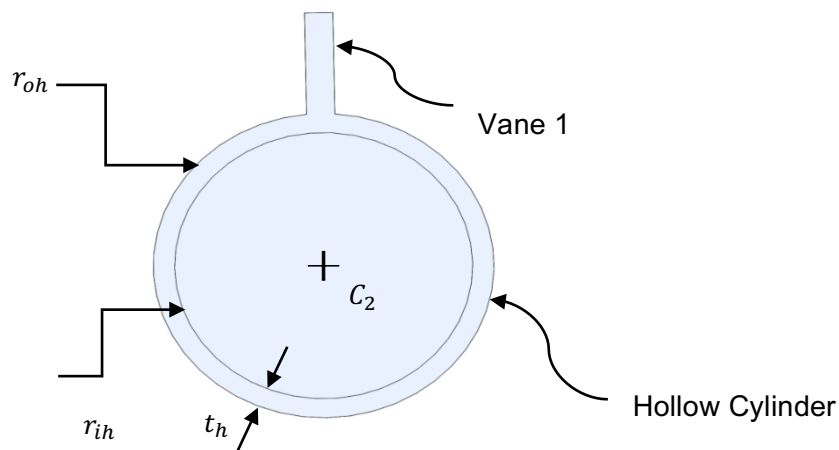

**Figure 6.** Top sectional view of hollow cylinder and vane 1

### 3.1.3. Inner cylinder

The innermost part of MCRC is the inner cylinder, where the centre axis of inner cylinder ( $C_1$ ) coincides with the centre axis of the outer cylinder as shown in Figure 7. Another vane namely vane 2 is attached to the inner cylinder through a spring. The other end of vane 2 is in contact with the inner surface of the hollow cylinder. A slot is created from the outer surface of the inner cylinder towards the centre of the inner cylinder to contain the spring and vane 2.

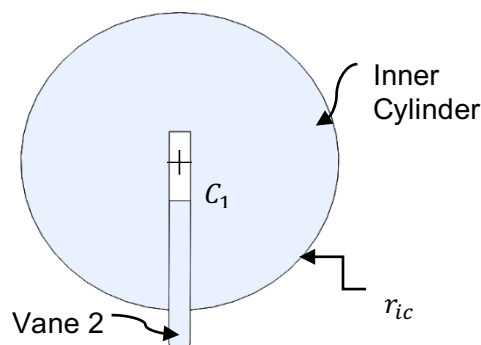
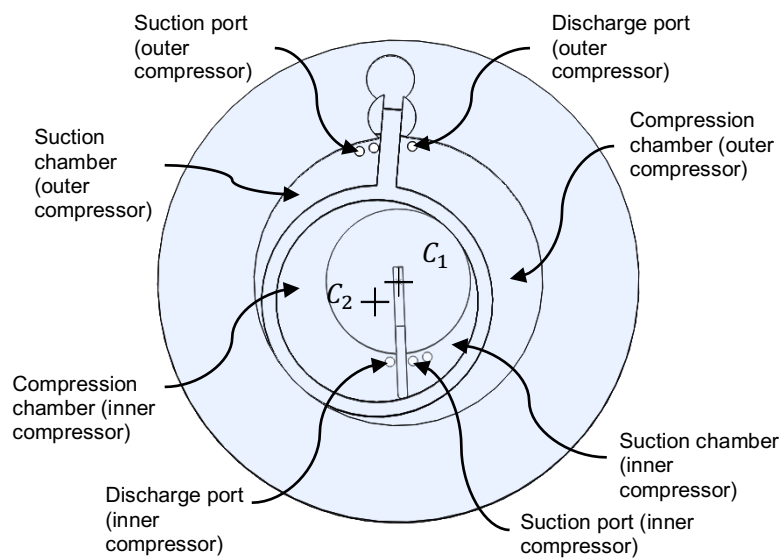

**Figure 7.** Top sectional view of inner cylinder and vane 2

During operation, vane 2 slides in and out of the slot while the spring exerts a force to push the vane to ensure that it is always in contact with the inner surface of the hollow cylinder. The tip of vane 2 that is in contact with the inner surface of the hollow cylinder is curved to allow for a smoother sliding and to reduce frictional loss at the contacting point.

### 3.2 Assembly of MCRC

The working chambers are formed by assembling the outer cylinder, the hollow cylinder and the inner cylinder on a base plate as shown in Figure 8. For the outer compressor, vane 1 and the contact line between the inner surface of outer cylinder and the outer surface of hollow cylinder have divided the working chambers into suction chambers and compression chambers. Similarly, the working chamber of the inner compressor is divided by the contact lines between inner surface of hollow cylinder, the inner cylinder surface and vane 2. The suction ports and discharge ports are located at the base plate as shown in the same figure.



**Figure 8.** Schematic diagram of the assembly of MCRC

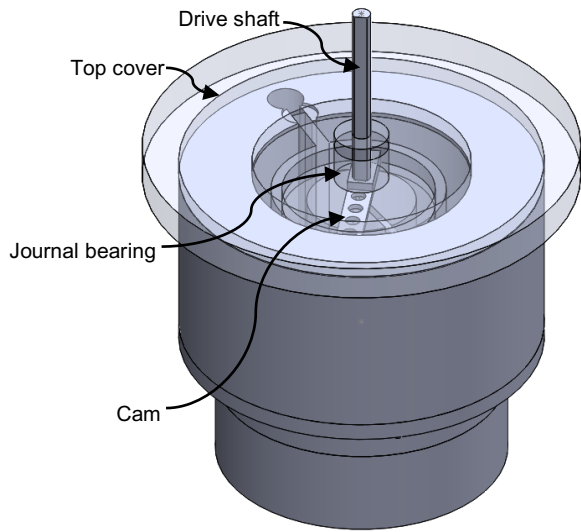

**Figure 9.** Isometric view of MCRC

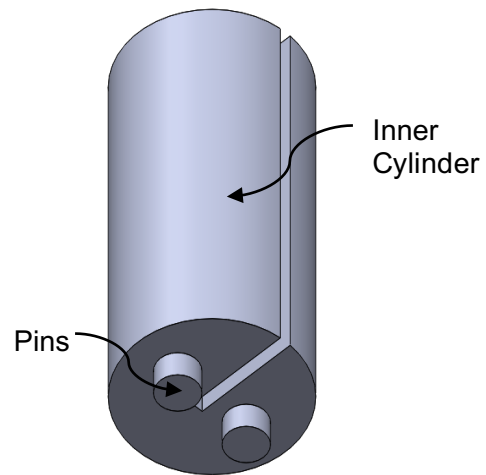

**Figure 10.** Features at the bottom of inner cylinder

Figure 9 shows a cam-shaft which will be connected to the prime mover drives the compressor. The shaft is held by a journal bearing and is coupled to a motor. When the cam-shaft rotates, it rotates the hollow cylinder and results in the rolling motion of the hollow cylinder. Since the inner cylinder and outer cylinder are stationary, the centre of the hollow cylinder ( $C_2$ ) is rotating about the point  $C_1$ . This rotation causes vane 1 to slide along the slot of the split bush and rotates about the centre axis of the split bush. The inner cylinder is held stationary by the two pins as shown in Figure 10. Noted that both outer and inner compressors operate simultaneously.

From the assembly,  $C_1$  and  $C_2$  is separated by a distance  $e$ , which is defined as Equation (1)

$$e = r_{ih} - r_{ic} = r_{oc} - r_{oh} \quad (1)$$

where,

$r_{ih}$  is the inner radius of the hollow cylinder (m)

$r_{ic}$  is the radius of the inner cylinder (m)

$r_{oc}$  is the radius of the outer cylinder (m)

$r_{oh}$  is the outer radius of the hollow cylinder (m)

The outer radius of the hollow cylinder  $r_{oh}$  must be specified based on the following equation

$$r_{oh} = \frac{1}{2}(r_{oc} + r_{ic} + t_h) = e + r_{ic} + r_{ih} + 2t_h \quad (2)$$

where,

$t_h$  is the thickness of the hollow cylinder (m)

The inner radius of the hollow cylinder can then be defined as

$$r_{ih} = r_{oh} - t_h \quad (3)$$

Hence, the independent dimensions  $r_{oc}$ ,  $r_{ic}$  and  $t_h$  must be pre-determined to define the dependent dimensions  $e$ ,  $r_{oh}$  and  $r_{ih}$ .

### 3.3 Working principle of MCRC

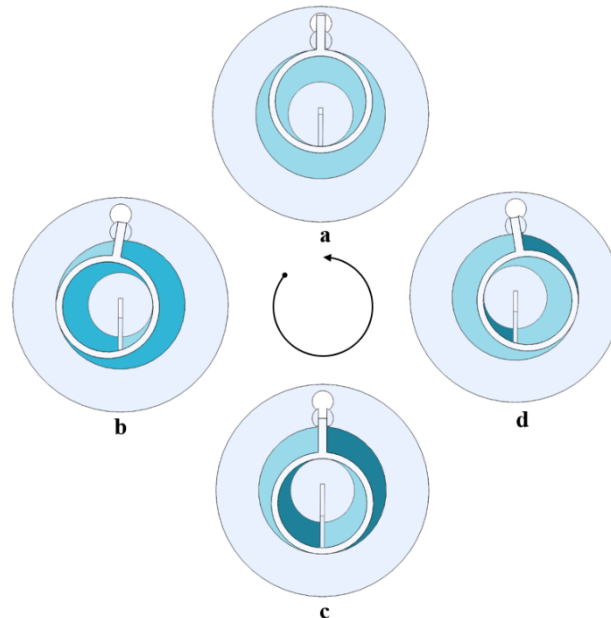

**Figure 11.** Operating process of MCRC

Figure 11 shows the suction, compression and discharge processes of the MCRC. Figure 11a indicates the end of suction process and the start of compression process. As the shaft rotates and the hollow cylinder moves, the volumes of the compression chambers of both outer and inner compressor decrease and hence resulting in the compression of the working fluid. Simultaneously, low pressure working fluid is being drawn into the suction chambers of both compressors, which are shown in Figure 11b and 11c. When the pressure of the working fluid in the compression chamber reaches the desired discharge pressure, the reed valve will open the discharge process begins, which is somewhere between Figure 11d and Figure 11a. While the low pressure working fluid is being drawn to the compressor, the compressed working fluid is being discharged uninterruptedly until the hollow cylinder back to the position as presented in Figure 11a.

The refrigerant will enter the compressor via two streams, inner compressor and outer compressor. The refrigerant of each stream will first go through the suction chamber and then the discharge chamber. At the end of the discharge process, working fluid from both inner and outer discharge chambers will be discharged to a reservoir which will then lead to condenser through a pipe. The ratio of flow rate in the case will be determined by the rate of change of the volumes of inner and outer chamber.

## 4. Discussion

A qualitative comparison on the basic information between various types of rotary compressors and MCRC is shown in table 1.

**Table 1.** Comparison between various types of rotary compressors and MCRC [20].

Feature	Rolling Piston Compressor	Rotary Sliding Vane Compressor	Swing Compressor	MCRC
Number of major components	4 components	At least 3 components	3 components	5 components

<b>Simplicity of components geometry</b>	Cylindrical profile for major components	Cylindrical or oval for major components	Cylindrical profile for major components	Cylindrical profile for major components 1
<b>Size</b>	Larger for a given working fluid capacity	Larger for a given working fluid capacity	Larger for a given working fluid capacity	Smaller for a given working fluid capacity
<b>Working fluid capacity</b>	Lower fluid intake for a given size and mass	Lower fluid intake for a given size and mass	Lower fluid intake for a given size and mass	Higher fluid intake due to more working chambers
<b>Frictional Losses</b>	High due to vane tip friction and vane jumping	High due to vane tip frictional loss	Lower as compare with RP and RSV compressor	Lower as compare with RP and RSV compressor

The current stage of study is unable to provide experimental result and comprehensive theoretical model. In future work, comparison will be made more accurate, the mechanical efficiencies and compressor performance will be evaluated after complete theoretical and experimental work are carried out.

## 5. Conclusion

A new compressor namely multi-chamber rotary compressor (MCRC) is introduced. The basic components of MCRC comprise of an outer cylinder, a hollow cylinder and an inner cylinder. The shapes of these components are mostly in cylindrical for the ease of manufacturing. The assembly of these components forms inner and outer “compressors” working simultaneous. As compared to the rolling piston compressor, the device utilizes the space that was originally occupied by the roller, hence this new design is expected to be more compact.

However, at the current stage of study, the model is assumed to be going through adiabatic process, perfect sealing and no internal leakage, and frictional losses are not accounted in the mathematical model yet. In real life situation, the model is expected to experience internal leakage, heat transfer losses and frictional losses. The objective of this paper is to introduce the working principle and design, which takes the limitations of previous rolling piston compressors and swing compressors into account. Most of the parts are cylindrical which are reasonably easy to manufacture and it is forecasted to be more energy efficient.

## Acknowledgment

We wish to acknowledge the funding for this project from Nanyang Technological University under the Undergraduate Research Experience on CAmpus (URECA) programme.

## References

- [1] "The Montreal Protocol on Substances that Deplete the Ozone Layer," ed. Kenya: United Nations Environment Programme Ozone Secretariat, 1987.
- [2] "Kyoto Protocol to the United Nations Framework Convention on Climate Change," ed. Kyoto: United Nations, 1997.
- [3] TheGuardian, “Paris climate change agreement enters into force,” Available: <https://www.theguardian.com/environment/2016/nov/04/paris-climate-change-agreement-enters-into-force>

- [4] D. Ürge-Vorsatz, L. F. Cabeza, S. Serrano, C. Barreneche, K. Petrichenko, "Heating and cooling energy trends and drivers in buildings," *Renewable and Sustainable Energy Reviews*, vol. 41, pp. 85-98, 2015
- [5] CASCOUSA. (2016, 08-July). *Types of Compressors*. Available:<http://cascousa.com/compressed-air-101/types-of-compressors/dynamic-displacement-compressors/>
- [6] L. Li, Y. Zhao, B. Guo, P. Shu, J. Shen, and S. He, "Wrap of cylinder and its effect on main features of rotary vane compressor for automobile air conditioning system," *International journal of refrigeration*, vol. 26, pp. 566-574, 2003.
- [7] G. Bianchi and R. Cipollone, "Theoretical modeling and experimental investigations for the improvement of the mechanical efficiency in sliding vane rotary compressors," *Applied Energy*, vol. 142, pp. 95-107, 2015.
- [8] K. T. Ooi, "Design optimization of a rolling piston compressor for refrigerators," *Applied Thermal Engineering*, vol. 25, pp. 813-829, Apr 2005.
- [9] T. Yanagisawa and T. Shimizu, "Friction losses in rolling piston type rotary compressors. III," *International journal of refrigeration*, vol. 8, pp. 159-165, 1985.
- [10] Y. Liu and J. Kosco, "Vane Dynamics Analysis of a Tilted Vane Rotary Compressor," 1998.
- [11] J. Bae, J. Kim, B. Lee, T. Noh, and S. Byun, "Vane jumping in rotary compressor," 1998.
- [12] P. Pandeya and W. Soedel, "Rolling piston type rotary compressors with special attention to friction and leakage," 1978.
- [13] C. Costa, R. Ferreira, and A. Prata, "Considerations about the leakage through the minimal clearance in a rolling piston compressor," 1990.
- [14] T. Yanagisawa and T. Shimizu, "Leakage losses with a rolling piston type rotary compressor. II. Leakage losses through clearances on rolling piston faces," *International journal of refrigeration*, vol. 8, pp. 152-158, 1985.
- [15] J. Lee, "Performance analysis of rolling piston type rotary compressor," 1988.
- [16] T. Ohkawa, E. Kumakura, H. Higashi, K. Sakitani, M. Higuchi, H. Taniwa, *et al.*, "Development Of Hermetic Swing Compressors For CO2 Refrigerants," 2002.
- [17] M. Masuda, K. Sakitani, Y. Yamamoto, T. Uematsu, and A. Mutoh, "Development of swing compressor for alternative refrigerants," 1996.
- [18] K. Furusho, T. Okawa, K. Saitoh, and K. Sakitani, "Numerical and Experimental Investigation of Swing Compressor Characteristics," 1998.
- [19] X. Hu, Z. Qu, X. Yang, and J. Sun, "Theoretical study on frictional losses of a novel automotive swing vane compressor," *International Journal of Refrigeration*, vol. 36, pp. 758-767, 2013.
- [20] K. S. Yap, K. T. Ooi, and A. Chakraborty, "Introduction of the Novel Cross Vane Expander-Compressor Unit for Vapour Compression Cycle," 2014.