



Differences in pulse manifestations at Cunkou based on simplified modeling of tactile sensing

SHI Yubing^{a, b*}, YANG Hongyi^a, YEO Joon Hock^c

a. Institute of Integrative Medicine, Shaanxi University of Chinese Medicine, Xiayang, Shaanxi 712046, China

b. Department of Mechanical, Materials & Manufacturing Engineering, University of Nottingham Malaysia Campus, 43500 Semenyih, Selangor Darul Ehsan, Malaysia

c. School of Mechanical and Aerospace Engineering, Nanyang Technological University, 639798, Singapore

ARTICLE INFO

Article history

Received 11 December 2023

Accepted 26 February 2024

Available online 25 March 2024

Keywords

Pulse manifestation

Traditional Chinese medicine (TCM)

Cunkou

Tactile sensing

Mathematical model

ABSTRACT

Objective In the theories of pulse diagnosis in traditional Chinese medicine (TCM), it is emphasized that pulse manifestations at the radial artery within the wrist (called Cunkou) signify the physiological and pathological conditions of different internal organs in the human body. However, different opinions exist among researchers about the objectiveness of the pulse diagnosis technique. Some researchers mentioned that no significant differences were observed in pulse manifestations at various Cunkou areas, hence there might be some difficulty in evaluating the status of different organs through checking pulse manifestations at Cunkou. This research aims to analyze the pulse response at Cunkou from the aspect of the characteristics of tactile sensing, thus to give a preliminary explanation to the above question.

Methods This research utilized the Weber-Fechner law to model the tactile sensing as a dynamic low-pass signal filter with varying bandwidths under different compression levels during pulse diagnosis. The model was applied to analyzing the clinical data collected previously by our group. The arterial pressures measured invasively with equipment from 14 patients with aorta coarctation were processed to simulate different pulse manifestations at Cun, Guan, and Chi positions of Cunkou when different compression levels were applied.

Results Due to the characteristics of tactile sensing, significant variations were observed in pulse manifestations at different pulse-depths under the application of changing compression levels; while no such changes in pulse manifestations were observed from the employment of transducer only, without tactile sensing involved. The results explained why different understandings on pulse manifestations were formed between direct pulse-taking technique in TCM and modern sphygmography using transducers. The features of pulse manifestations at Cunkou, using direct pulse-taking technique but at different depths, superficial, middle, and deep positions, respectively, predicted by the developed tactile sensing model were in line with those described in TCM pulse theories.

Conclusion Based on the developed tactile sensing model, this study preliminarily explains the phenomenon that pulse manifestation at Cunkou changes in response to the compression force applied during TCM pulse-taking. Integrating the tactile sensing model with the study of TCM pulse diagnosis opens a new chapter for visualizing and quantitatively interpreting pulse manifestations. This not only expands the scope of pulse diagnosis study effectively, but also provide a scientific basis for further technical upgrading and optimization of existing pulse diagnosis equipment.

*Corresponding author: SHI Yubing, E-mail: yshi@sntcm.edu.cn.

Peer review under the responsibility of Hunan University of Chinese Medicine.

DOI: [10.1016/j.dcmcd.2024.04.004](https://doi.org/10.1016/j.dcmcd.2024.04.004)

Citation: SHI YB, YANG HY, YEO JH. Differences in pulse manifestations at Cunkou based on simplified modeling of tactile sensing. Digital Chinese Medicine, 2024, 7(1): 29-39.

1 Introduction

Pulse diagnosis, as one of the four traditional Chinese medicine (TCM) diagnostic techniques, plays an important role in the clinical practice of TCM. In TCM, it's theorized that Qi, the vital life energy, traverses meridians within the human body, guiding the circulation of blood. Qi regulates the blood flow within the radial artery at the wrist, exhibiting various physiological and pathological states at the specific point known as Cunkou on both the left and right wrists. The Cunkou area is subdivided into three segments known as Cun, Guan, and Chi. During pulse diagnosis, the physicians place their fingertips on the patient's Cunkou, employing their index, middle, and ring fingers to perceive pulsations at Cun, Guan, and Chi positions. Varied compression was applied to the fingertips to discern the differing intensities of pulsation at the superficial, middle, and deep layers beneath the skin at Cunkou. According to TCM theories, the pulse readings obtained from Cun, Guan, and Chi positions on both the left and right wrists provide insights into the physiological and pathological conditions of various internal organs such as the heart, liver, kidney, lung, spleen, and gall bladder [1]. The infusion of modern scientific and technological advancements has revitalized this ancient practice, empowering it with cutting-edge tools and methodologies. Contemporary research techniques such as biofluid and quantum physical modeling [2-4], statistical analysis of clinically measured data [5-11], and the utilization of machine learning for clinical syndrome differentiation [12-18] have been extensively employed by researchers to investigate the inner workings and the underlying mechanisms of this valuable yet enigmatic diagnostic procedure.

Despite the widespread utilization of pulse diagnosis in TCM clinical settings, and its generally acknowledged effectiveness and validity, there remains a divergence of opinions among researchers as to the physiological mechanisms underlying pulse manifestations and the objectiveness of the pulse diagnosis technique. FERREIRA et al. [19] summarized the arguments into two major questions: (i) whether the pulse waveforms at Cun, Guan, and Chi positions exhibited distinct characteristics from one another; (ii) whether a clear correspondence existed between the pulse waveforms observed at Cun, Guan, and Chi positions and the health status of the internal organs mentioned earlier. It is crucial for researchers to find answers to these fundamental questions through logical reasoning, clinical observation, or laboratory investigation using modern facilities.

TCM theories state that pulse manifestations at Cunkou of both hands characterize the functional state of the

internal organs, and serve as important evidences of diseases [1]. Besides, some scholars have expanded this theory, pointing out that pulse manifestations at Cunkou indicate the physiological and pathological conditions of not only the aforementioned internal organs, but also a broader spectrum of organs and tissues throughout the body, including the brain, eyes, ears, arms, legs, and feet [20-23], and they asserted that this claim was rooted in the years of their clinical experience. In contrast, some researchers have argued that the theory of pulse-organ correspondence lacks logical consistency and sufficient scientific support [24, 25]. Modern scientific and technological advancements have illuminated potential solutions to this question, allowing researchers to employ engineering sensors for measuring pulse responses. Subsequently, the captured pulse signals were analyzed to deduce their relationship with health conditions [26]. WANG et al. [27] measured the pulse waves at the Cun, Guan, and Chi positions with sensors, and reported no visible differences in the pulse waveforms captured. CHU et al. [28] utilized a sensor array to measure pulse parameters at the Cun, Guan, and Chi positions, and in different depths under the skin, the superficial, middle, and deep, respectively. They observed that the pulse wave signals at the above positions and depths exhibited considerable similarity, although variances were observed in the specific characteristic parameters such as peak value, ascending slope in several selected cases. Overall, the imperative issue in this field is why there are such controversial opinions on the differences in pulse responses, with supporting evidences on both sides.

To answer the aforementioned question, WANG et al. [27] referred to the Weber-Fechner law in tactile sensing modeling. The Weber-Fechner law is a widely used principle in the field of psychophysics, which describes the relationship between the physical stimuli and their perceived intensity [29]. Pulse diagnosis serves as a classic example of the Weber-Fechner law, in which the physician perceives varying intensities of throbbing sensation beneath their fingertips in response to the physical stimuli associated with the changing radial pressure on patients. According to WANG et al. [27], tactile sensing in humans followed the Weber-Fechner law, meaning that the sensitivity of tactile perception at the fingertip reduced as the applied pressure elevated. When physicians applied varying pressure forces at the fingertip, different ranges of harmonics in the pulse wave signal were captured, resulting in dissimilar pulse manifestations. Inspired by this interesting observation, a simple quantitative model was constructed in our previous study to characterize the tactile sensing at the fingertip based on the Weber-Fechner law, with the tactile sensing at Cun,

Guan, and Chi positions visualized by an ideal low-pass signal filter of different frequency bandwidths corresponding to the varying sensitivities under different compression levels applied [30]. This tactile sensing model was applied to the analysis of the arterial pressure signal from Fourier transformation in clinical settings. Surprisingly, pulse readings obtained from the model complied well with the descriptions in TCM theories. The study served as a preliminary support to the explanation stated above [27]. However, the model developed in our previous study [30] was over-simplified and insufficiently tested. To overcome these deficiencies and obtain more reliable results, this paper further refined the tactile sensing model constructed previously and applied the refined model to analyze the clinical datasets collected from a cohort of patients, hoping to provide a new angle to view pulse manifestations and clarify the mysterious pulse diagnosis technique.

2 Data and methods

This study aimed to enhance the tactile sensing model constructed in our previous study [30] and validate the enhanced model using a wide range of patient data. Several weaknesses were identified in the previously developed model. First, in the previous model, tactile sensing was characterized as an ideal signal filter that preserved signals below the cutoff frequency while completely removing signals above the cutoff frequency. However, in actual filters, there is always a transition band around the cutoff frequency, where signals in the low range (below the cutoff frequency) are partially distorted, while those within the high range (above the cutoff frequency) are partially attenuated. Second, in the previous model, the bandwidth of the filter was defined based on the wave number, representing specific harmonics of the patient's arterial pressure signal in the frequency domain. However, in a realistic scenario, the bandwidth of tactile sensing is influenced by the compression applied by physicians' fingertip, rather than by the arterial pressure signal of the patient. Third, the previous model was formulated in the frequency domain, whereas the arterial data from test patients were presented in the time domain. Consequently, for analysis purposes, the arterial data had to be transformed between the time and the frequency domains using Fourier and inverse Fourier transformations, which was not only troublesome but also prone to errors. These flaws were rectified in the current study, with implementation details explained in the following sections.

2.1 Neural receptors related to tactile sensing

DAHIYA et al. [31] summarized four types of neural receptors in association with human tactile sensing, each of

which responds to external stimuli within different frequency ranges. The receptors include the Meissner body distributed in the superficial skin that responds quickly to external stimuli at 3 – 40 Hz, the Pacinian body distributed in deep layers of the skin that responds quickly to stimuli above 40 – 500 Hz, the Merkel cell that responds slowly to external stimuli at 0.4 – 30 Hz between epidermal basal cells, and the Ruffini body distributed in the dermis that responds slowly to external stimuli above 100 – 500 Hz. Since the amplitude of each harmonic in the human pulse wave decreases exponentially as the frequency of the harmonic component increases, only the first 20 harmonics in the frequency spectrum of the pulse wave hold significance in various physiological and pathological conditions within the human body [32, 33] (note that the frequency of a specific harmonic equals the harmonic number multiplied by the frequency of the base harmonic. For example, if the frequency of the base harmonic is 1.2 Hz, then the frequency of the fifth harmonic is $5 \times 1.2 \text{ Hz} = 6 \text{ Hz}$). Thus, only two of the aforementioned neural receptors, namely the Meissner body and the Merkel cell, play a role in pulse diagnosis, as the relevant pulse wave harmonics fall within the functional ranges of these neural receptors. While these neural receptors generally exhibit behavior akin to low-pass filters, their precise characteristics remain unclear [31].

2.2 The Weber-Fechner law in tactile sensing

WANG et al. [27] mentioned that human tactile sensing adhered to the Weber-Fechner law. Applying the Weber-Fechner law [29] to tactile sensing in pulse diagnosis, the threshold value of tactile sensing δx is proportional to the magnitude of the tactile force x applied, i.e.,

$$\delta x = c \cdot x \quad (1)$$

Here c is a non-dimensional constant whose value is determined by the specific application scenario. Thus, as physicians apply a great tactile force x at their fingertip onto the patient's wrist, the sensitivity of their tactile sensing diminishes, and they can only distinguish variations in tactile force that is greater than δx .

2.3 General mechanism of pulse feeling

As illustrated in Figure 1, the arterial pressure waveform as a periodic signal in the time domain could be effectively decomposed into various combinations of frequency components, based on the Fourier transformation theory. Based on the Weber-Fechner law, tactile sensing at the physician's fingertip exhibited varying degree of sensitivity. Consequently, it captured changing ranges of frequency components in the arterial pressure signal. Again,

based on the theory of Fourier transformation, the captured frequency components were combined to produce the arterial pressure waveform with varying shapes, corresponding to the different levels of compression force applied. In this procedure, tactile sensing acted as a low-pass filter (i.e., a component that passes low frequency signals but blocks high frequency signals), with its bandwidth adjusted in response to the applied compression force.

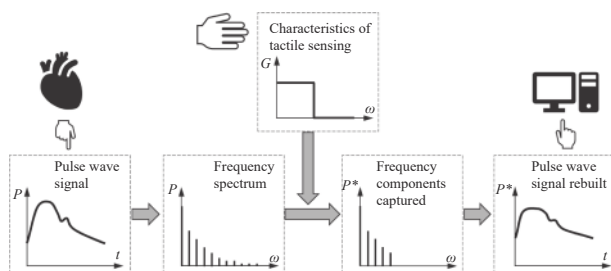

Figure 1 The filtering process of the arterial pressure wave by tactile sensing

P , the magnitude of pressure. P^* , the magnitude of the rebuilt pressure signal. t , time. ω , frequency. G , magnitude of the filter.

Anatomy textbooks suggest that the depth of the radial artery beneath the skin gradually increases from Cun position to Guan position and then to Chi position [34, 35]. Thus the compression force required at the physician's fingertip to detect a clear pulse in each of the aforementioned positions increases sequentially: Cun requires light compression, Guan moderate compression, and Chi strong compression. Light compression at Cun is associated with a relatively low sensory threshold value (i.e., greater sensitivity), enabling the capture of more frequency components in the pulse wave spectrum. As compression increases at Guan and Chi positions, sensitivity reduces, resulting in the capture of fewer frequency components in the pulse wave spectrum. Consequently, distinct arterial pressure waveforms are obtained at the respective Cun, Guan, and Chi positions.

When measuring the pulse pressure at Cunkou using regular engineering sensors, such as strain gauge-type or piezoelectric-type pressure sensors, these sensors often have a frequency bandwidth exceeding 1000 Hz. The bandwidth of the sensors is an inherent characteristic that does not alter as the compression force between the sensors and the skin at Cunkou changes, regardless of the compression applied to the sensors. Thus, the sensors always picked up all the frequency components at Cun, Guan, and Chi positions, leading to similarities in pulse waveforms at the three positions. Surely, when different compression forces are applied, the strain or the pressure detected will have different magnitudes, and the sensors will report different magnitudes but similar shapes in pulse waveforms at the three positions under

varying compression force, which explains why physicians felt different pulse manifestations at Cun, Guan, and Chi positions within Cunkou but the sensors reported identical pulse waveform.

2.4 Data source and derivation of representative arterial pressure waveform

In TCM pulse diagnosis, the physician feels the pulsation within the radial artery at patients' wrist, and evaluates their health conditions in accordance with their subjective experiences towards changes in the radial pressure underneath his/her fingertips. For an objective study, the radial pressure needs to be measured first. As safe and easy as the measurement of the radial pressure with non-invasive equipment is, the approach still suffers from inaccuracy associated with the flawed contact between the skin and the sensor as well as the non-linearity in mapping the skin deflection to the artery pressure data. For a high-fidelity analysis, this study employed the invasively measured data on aortic pressure as a surrogate for the radial pressure. While there may be differences in waveform shape between ascending aortic pressure and radial arterial pressure [36], physicians may not always consider this disparity in daily clinical practice. Instead, they frequently utilize radial pressure as a surrogate for ascending aortic pressure when assessing heart workload and diagnosing diseases [37, 38]. This study adhered to this practice and regarded the collected ascending aortic pressure data as a reliable approximation of radial arterial pressure.

This study utilized clinical data that were previously collected by our group in a study concerning aorta coarctation (AoCo) [39, 40]. The data were collected from patients admitted at St. Thomas' Hospital, London, between June 2007 and June 2011. The study was approved by the local research ethics committee (R&D REC 08/H0804/134), and formal authorization was granted for reusing the data in the current research. The study population consisted of 14 patients with different degrees of AoCo condition. The cohort was aged 21 ± 7 years, weighed 71 ± 16 kg, with heart rates of 64 ± 14 bpm and cardiac outputs of 4.62 ± 1.05 L/min. Inclusion criteria and exclusion criteria were detailed in the previous report [41].

The data collection procedure followed the process detailed in the previous report [41], in which X-ray guided cardiac catheterization was conducted to measure blood pressure at the ascending aorta and the diaphragm positions at a sampling rate of 1000 Hz. Pressure data were collected for about 1 min from each of the 14 patients. Throughout the procedure, patients maintained calm breathing.

An in-house script was developed and executed

within the MATLAB environment (version R2013, Mathworks Inc., MA, USA) to process the collected data from each patient. First, the data sequence was divided into different heart cycles based on the features of the maximum and minimum values within each cycle. Subsequently, statistical analyses were applied to the segmented data cycles to determine the mean values and standard errors of various cardiac indices including peak systolic pressure, trough diastolic pressure, heart period, and peak pressure rising time (the duration from the start of the heart cycle to the instance corresponding to the peak systolic pressure). Cycles with any of the aforementioned indices deviating significantly from their mean values (i.e., values outside the range of $\text{mean} \pm \text{standard error}$) were considered as invalid and discarded. The original dataset typically contained 50 – 80 heart cycles, corresponding to 1 min of recording time. Following statistical processing to exclude those invalid cycles, typically 20 – 40 clean cycles remained. The mean value of the heart periods in the remaining cycles was then selected as the reference heart period. A representative data cycle for the ascending aortic pressure for each patient was subsequently constructed by interpolating from and averaging the remaining cycles. Specific details regarding data processing can be found in previous reports [39, 40].

2.5 Computer implementation of the pressure waveform filtering to represent the pulse diagnosis process

The above sections explain qualitatively the mechanism for obtaining different arterial pressure waveforms at Cun, Guan, and Chi positions during pulse diagnosis. To analyze the procedure quantitatively, a Simulink model (Figure 2) was developed in this study to calculate the detailed pressure responses at the three positions using the data collected from the 14 patients enrolled. The arterial pressure waveform was input into three low-pass filters that represent the tactile sensing characteristics at Cun, Guan, and Chi positions. Since tactile sensing at Cun, Guan, and Chi positions had different sensitivity due to the varying compression force applied, various filters were used to reflect the variations in the frequency band and the attenuation rate at the cutoff frequency. Tactile sensing at Cun position, being the most sensitive one among the three, was represented by a second order Butterworth filter. This filter effectively captures a flat amplitude response below the cutoff frequency and a steep attenuation rate above the cutoff frequency. The transfer function $G(s)$ of this filter can be represented by:

$$G(s) = \frac{1}{b_0 s^2 + b_1 s + 1} \quad (2)$$

In Equation (2), the coefficients b_0 and b_1 can be

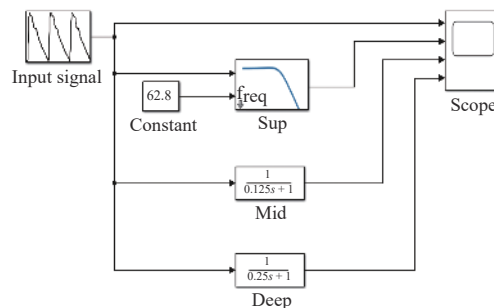

Figure 2 Simulink model for calculating perceived responses at Cun, Guan, and Chi positions

The block labeled as input signal is a repeating sequence block, which converts the arterial pressure waveform representative of each patient into a periodic waveform and serve as the source signal for the model; the three low-pass filters labeled as sup, mid, and deep represent the tactile sensing characteristics at Cun, Guan, and Chi positions. Here, sup, mid, and deep denote the different pulse depths of superficial, middle, and deep where the clear pulse manifestations are captured. The outputs from the three filters are directed into the scope block for graphical illustration and data recording purposes.

tuned to achieve the expected cutoff frequency and the flat amplitude response below the cutoff frequency. Tactile sensing at Guan and Chi positions was modeled using a transfer function block in the form of an inertial element, specifically a first order Butterworth filter. This representation accounts for the less perceptive response characteristics at these locations, which accompany the stronger compression force applied. The transfer function is in the following form:

$$G(s) = \frac{1}{Ts + 1} \quad (3)$$

The coefficient T in Equation (3) can be adjusted to modify the bandwidth to accommodate specific modeling requirements at Guan and Chi positions.

The literature suggests that in most situations only the first 12 harmonics in the frequency spectrum of the pulse wave exhibit sufficient strength to be clearly identified [32, 33]. With no reference data available in the literature, as a preliminary study this research approximately divided the frequency band corresponding to the 12 harmonics into several intervals, and prescribed $\omega_n = 2\pi \times 10 \text{ Hz} = 62.8 \text{ rad/s}$ as cutoff frequency at Cun position, $\omega_n = 2\pi \times 8 \text{ Hz} = 50.2 \text{ rad/s}$ for Guan position, and $\omega_n = 2\pi \times 4 \text{ Hz} = 25.1 \text{ rad/s}$ for Chi position. As a result, in Equation (2), the two coefficients were set as $b_0 = \frac{1}{62.8^2} = 0.00025$ and $b_1 = \frac{2}{62.8} = 0.032$, to model the tactical perception at Cun position. In Equation (3), the coefficient was set as $T = \frac{1}{8 \text{ Hz}} = 0.125 \text{ s}$ for Guan position and $T = \frac{1}{4 \text{ Hz}} = 0.25 \text{ s}$ for Chi position.

For the simulation, a fixed time step of 0.005 s was employed following the mesh independent test conducted with several candidate time step values. The solver selection was configured to the auto mode, allowing Simulink to internally choose the optimal solver from a range of available candidate solvers based on the signal variation condition.

2.6 Features of the pulse manifestation summarized in TCM literature

Before comparing the simulated pulse manifestations using the model developed in this study with the descriptions in TCM theories, it's necessary to first summarize the features of pulse manifestations as described in previous reports concerning TCM. Numerous pieces of literatures concerning TCM have depicted pulse features, often portraying a physician's subjective sensation of pulse manifestations at various Cunkou locations through metaphorical language. This study opted to utilize the renowned ones summarized by LI Zhongzi (1588 – 1655 AD, a famous TCM physician in Ming Dynasty) in his work *Zhen Jia Zheng Yan* (诊家正眼)^[42] as representative statements, saying “liver pulse feels like touching a string; heart pulse feels like a hook; ... lung pulse feels hairy; kidney pulse feels stony (肝脉弦; 心脉钩; 肺脉毛; 肾脉石)”. The statements can be translated and rephrased as follows: the pulse at the Cun position (i.e., the heart pulse on the left-hand side and the lung pulse on the right-hand side) is strong and shallow, akin to a powerful hook used in fighting and they are felt superficially, like a bird's feather floating in the air; the pulse at Guan position (i.e., liver pulse) has an extended percussion on the fingertip, and feels like touching a fully-strung line; the pulse at Chi position (i.e., kidney pulse) is weak and slippery, akin to a stone sinking to the riverbed, and is felt deeply. Specifically, regarding the liver pulse, i.e., the pulse at Guan position, a contemporary sphygmology book describes its features in technical terms: “... exhibits an enlarged tidal wave that merges with the primary wave to form a wide single-peak wave. The dicrotic notch is elevated, and the dicrotic wave becomes flattened or even negative”^[1].

3 Results

3.1 Simulated pulse manifestations of a typical patient

Figure 3 showed that light compression at Cun position resulted in a response that was slightly different from the original arterial pressure waveform. However, pulse manifestations at Guan and Chi positions under mild and strong compression exhibited significant differences from

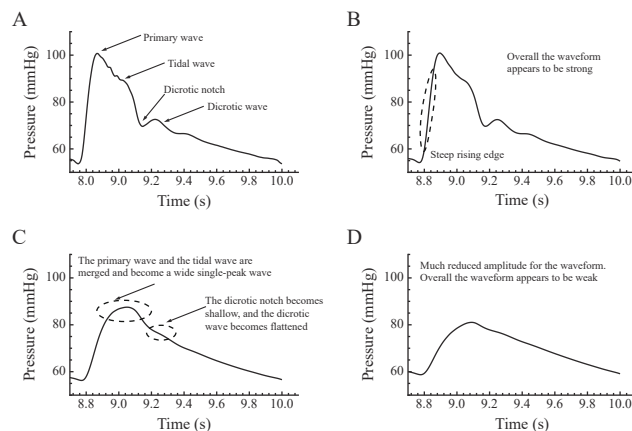

Figure 3 The prediction of pulse manifestations based on the arterial pressure of a typical patient

A, original arterial pressure. B, pulse at Cun position. C, pulse at Guan position. D, pulse at Chi position.

the original pulse wave, in terms of both waveform shape and amplitude. This suggests that, considering the characteristics of tactile sensing, pulse manifestations acquired by physicians at the patient's Cun, Guan, and Chi positions are indeed distinct.

Pulse manifestation at Cun position (Figure 3B) depicts a steep rising edge and a strong waveform, and the pulse is acquired with light compression, which aligns with the descriptions in TCM theories as summarized in section 2.6 above. Pulse at Guan position (Figure 3C) exhibits the characteristics of merged tidal and primary waves, a shallow dicrotic notch, and a nearly disappeared dicrotic wave, also conforming to the TCM theory. Pulse at Chi position (Figure 3D) demonstrates a greatly reduced waveform amplitude, besides, the pulse is felt at the deep level, thus it also matches the statements in TCM theories. Overall, the features of the simulated pulse manifestations conform to the descriptions in TCM theories.

3.2 Simulated pulse manifestations of the 14 patients

For comprehensive validation, the processing technique was applied to all 14 patients, and simulated pulse manifestations at Cun, Guan, and Chi positions are illustrated in Table 1. Although the pulse manifestations of the 14 patients varied, similar features like those described in Figure 3 were demonstrated in these pulse manifestations. These features were in line with the characteristics of pulse manifestations described in TCM pulse theories, as detailed in the above section. These results suggest that the processing technique proposed in this study effectively derived pulse manifestations from the measured arterial pressure data for the given patient cohort. This group test also serves as validation of the tactile sensing model developed, indicating that the model functions effectively on a wider range of patient data.

Table 1 Simulated pulse manifestations of the 14 patients

Case	Cun	Guan	Chi
1			
2			
3			
4			
5			
6			
7			
8			
9			
10			
11			

Table 1 Continued

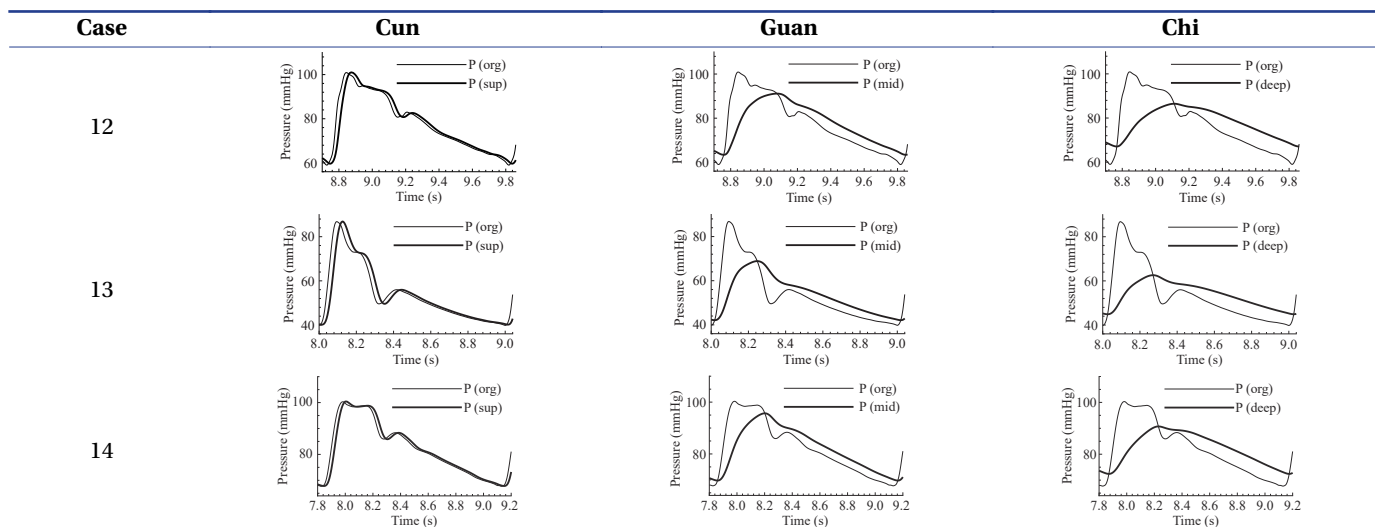

P (org), the original arterial pressure waveform. P (sup), the predicted pulse manifestation when pressing lightly to the superficial level at Cun position. P (mid), the predicted pulse manifestation when pressing mildly to the middle level at Guan position. P (deep), the pulse manifestation examined by pressing strongly to the deep level at Chi position.

4 Discussion

4.1 Study significance

The fundamental question of whether pulse manifestations at Cun, Guan, and Chi positions are similar or different has been the subject of longstanding debate among researchers. This study refined the concept and model developed in previous works [27, 30], developed a more intricate model of tactile sensing during pulse diagnosis, and tested it using arterial pressure data collected from 14 patients. Similar to the previous study [30], the model predicted that pulse manifestations at Cun, Guan, and Chi positions in this study complied with the descriptions in TCM classics. This further validates the explanation of WANG et al. that the varying sensitivity in tactile sensing due to different compression levels applied contributes to differences in pulse manifestations at Cun, Guan, and Chi positions [27].

Traditional pulse manifestations are explained in TCM classics through metaphor based on the physician's physical sensation, using sentences like "ill worm biting leaves" and "knife edge rubbing through bamboo" [1], which makes clear and precise description of the features of pulse manifestation difficult, impacting efficient and accurate communication about the diagnostic results. This study refined a model built by the previous work to better represent the characteristics of tactile sensing, which helped to objectively and quantitatively reveal differences in pulse manifestations at Cun, Guan, and Chi positions that physicians could normally perceive. Existing sphygmography studies have mostly recorded patients' pulse wave with sensors and compared the collected waveforms directly with the statements about pulse manifestations under different disease conditions in the

TCM literature [1, 19, 22, 26, 27]. Since most TCM literature discusses pulse manifestation, which is the subjective perception of the pulse wave through tactile sensing rather than the pulse wave itself, direct comparison between the two could lead to misunderstanding. The model developed in this study serves as a tool to bridge the gap between pulse manifestation and pulse wave, potentially bringing significant impact to concurrent studies on pulse diagnosis. Similarly, the model can be integrated into various pulse diagnosis equipment currently available on the market. This integration can upgrade the embedded pulse wave-based algorithms to pulse manifestation-based ones that better align with the descriptions in TCM classics. Consequently, this advancement can lead to more accurate disease identification and classification.

4.2 Further improvement on neuro perception modeling

This study constructed a simple low-pass filter model to represent the characteristics of tactile sensing, and applied it to analyze different pulse manifestations at Cun, Guan, and Chi positions around Cunkou region. This facilitates cost-effective derivation and examination of pulse manifestations from readily available pulse wave data. It aids researchers and physicians in visualizing the differences in pulse manifestations for more precise feature extraction. In this modeling study, the authentic representation of the tactile sensing procedure plays a pivotal role, determining the reliability and accuracy of the research output. For sophisticated analysis, it's crucial that the model for tactile perception is as accurate as possible. Human tactile sensing is a highly non-linear process governed by dynamic actions involving the inspiration, transmission, and processing of nerve stimulations. Additionally, it exhibits non-linear features such as time

delay, saturation, insensitivity zone, and hysteresis [31]. The simple low-pass filter model utilized in the current study represented the overall characteristics of tactile sensing. However, it did not individually consider the influences of the non-linear factors. To refine the model in the future, precise mathematical equations should be derived to represent the contributions of each of these factors, and then be integrated to improve the accuracy of tactile sensing. In addition, when deriving the governing equations for these factors to establish the model, attention is also required in setting values for the model parameters in the derived equations [39, 40]. Setting the parameters should meet two requirements. First, the predicted results by the model, including the pulse manifestation details, nerve inspiration, and transmission dynamics, should be consistent with data reported in previous literature and clinically measured data. This ensures that the model reliably represents human physiology. Second, the model parameters must be selected from within their normal ranges to form particular parameter combinations that represent the specific diagnosis intervention and perception features. These features include the level of compression applied during palpation, the sharpness of nerve sensation, and varied palpation maneuvers used by different TCM sects. This enables person-specific modeling to demonstrate the difference in pulse-taking operations and their influence on the obtained diagnostic results.

4.3 Integration with other studies on pulse wave for further breakthroughs

Pulse diagnosis, as both an art and a science, is highly complex and involves multiple dimensions and levels of inspection on the pulse response at the Cunkou region. To understand pulse diagnosis from the perspective of tactile sensing, as applied in this study, is just one of the many examination dimensions. The aim of the current study is to resolve the first question summarized by FERREIRA et al. [19], namely why pulse waves measured at Cun, Guan, and Chi positions were similar but the pulse manifestations felt by the physicians at these positions were different. Analysis of the results suggests that the explanation provided by this study has addressed the first question. However, analysis based on tactile sensing modeling has its limitations. The model was unable to answer the second question proposed, namely why pulse response at Cun, Guan, and Chi positions could represent the health status of the specific internal organ, as the TCM pulse diagnosis theories claimed. It is encouraging to see that there are numerous valuable and powerful techniques being used in pulse diagnosis studies, including biofluid and quantum physical modeling [2-4], statistical analysis on clinically measured data [5-11], and machine learning to aid clinical syndrome differentiation [12-18]. The current study centering on tactile sensing

must be combined with these techniques and involving studying TCM theories from a more in-depth level, in order to gain enlightenment on the underlying mechanism of pulse diagnosis and answer the second question. Only after that can the mysteries in pulse diagnosis be sufficiently revealed to support its application in clinical practice.

5 Conclusion

Through mathematical modeling analysis, this study showed that varying compression levels at Cun, Guan, and Chi positions generated various pulse responses at the three positions, and the pulse manifestations demonstrated aligned with the descriptions in TCM classics. Thus the tactile sensing model developed in this study can provide a preliminary quantitative explanation for the discrepancy in the opinions about pulse manifestations at the Cunkou region. Applying tactile perception modeling to visualize the originally subjective pulse manifestations effectively bridges the gap between clinically measured pulse wave data and the historical statements in TCM classics. This expands the scope of pulse diagnosis studies and has the potential to enhance the functionality of existing pulse diagnosis equipment.

Fundings

Ministry of Science, Technology and Innovation, Malaysia (06-02-12-SF0247), Natural Science Foundation of Shaanxi Province, China (2021JM-468), and Administration of Traditional Chinese Medicine of Shaanxi Province, China (SZY-KJCYC-2023-018).

Competing interests

The authors declare no conflict of interest.

References

- [1] FEI Z. Contemporary sphygmology in traditional Chinese medicine. Beijing: People's Medical Publishing House Co., Ltd., 2003.
- [2] FERREIRA AS. Resonance phenomenon during wrist pulse-taking: a stochastic simulation, model-based study of the 'pressing with one finger' technique. *Biomedical Signal Processing and Control*, 2013, 8(3): 229-236.
- [3] SHI YB, YANG XH. Hemodynamic modeling to study the association between pulse-taking depths and particular disease conditions in the pulse examination. *Beijing Biomedical Engineering*, 2021, 40(4): 385-392, 399.
- [4] SONG SN, SHE ZS. A new interpretation of TCM pulse diagnosis based on quantum physical model of the human body. *Digital Chinese Medicine*, 2022, 5(4): 360-366.
- [5] ZHANG CK, LIU L, WU WJ, et al. Identifying coronary artery

- lesions by feature analysis of radial pulse wave: a case-control study. *BioMed Research International*, 2021, 2021: 5047501.
- [6] CUI J, SONG LC. Wrist pulse diagnosis of stable coronary heart disease based on acoustics waveforms. *Computer Methods and Programs in Biomedicine*, 2022, 214: 106550.
- [7] XU HX, WANG Q, MAO XB, et al. Refined multiscale entropy analysis of wrist pulse for gender difference in traditional Chinese medicine among young individuals. *Evidence-Based Complementary and Alternative Medicine*, 2022, 2022: 7285312.
- [8] SHI YL, JIANG T, HU XJ, et al. A study of logistic regression for fatigue classification based on data of tongue and pulse. *Evidence-Based Complementary and Alternative Medicine*, 2022, 2022: 2454678.
- [9] JIANG ZX, ZHANG D, LU GM. Radial artery pulse waveform analysis based on curve fitting using discrete Fourier series. *Computer Methods and Programs in Biomedicine*, 2019, 174: 25–31.
- [10] CHEN YH, ZHANG L, ZHANG D, et al. Computerized wrist pulse signal diagnosis using modified auto-regressive models. *Journal of Medical Systems*, 2011, 35(3): 321–328.
- [11] FAN L, ZHANG JC, WANG ZM, et al. Application research of pulse signal physiology and pathology feature mining in the field of disease diagnosis. *Computer Methods in Biomechanics and Biomedical Engineering*, 2022, 25(10): 1111–1124.
- [12] LEUNG YLA, GUAN BH, CHEN S, et al. Artificial intelligence meets traditional Chinese medicine: a bridge to opening the magic box of sphygmopalpation for pulse pattern recognition. *Digital Chinese Medicine*, 2021, 4(1): 1–8.
- [13] CHEN XT, LEUNG YL A, SHEN JG. Artificial intelligence and its application for cardiovascular diseases in Chinese medicine. *Digital Chinese Medicine*, 2022, 5(4): 367–376.
- [14] SHI YL, LIU JY, HU XJ, et al. A new method for syndrome classification of non-small-cell lung cancer based on data of tongue and pulse with machine learning. *BioMed Research International*, 2021, 2021: 1337558.
- [15] WANG WY, ZENG WW, HE SL, et al. A new model for predicting the occurrence of polycystic ovary syndrome: based on data of tongue and pulse. *Digital Health*, 2023, 9: 20552076231160323.
- [16] LIU JL, DAN WC, LIU XD, et al. Development and validation of predictive model based on deep learning method for classification of dyslipidemia in Chinese medicine. *Health Information Science and Systems*, 2023, 11(1): 21.
- [17] LIM J, LI JY, FENG X, et al. Machine learning classification of polycystic ovary syndrome based on radial pulse wave analysis. *BMC Complementary Medicine and Therapies*, 2023, 23(1): 409.
- [18] LIU XY, HUANG XQ, ZHAO JD, et al. Application of machine learning in Chinese medicine differentiation of dampness-heat pattern in patients with type 2 diabetes mellitus. *Heliyon*, 2023, 9(2): e13289.
- [19] FERREIRA AS, LOPES AJ. Pulse waveform analysis as a bridge between pulse examination in Chinese medicine and cardiology. *Chinese Journal of Integrative Medicine*, 2013, 19(4): 307–314.
- [20] WANG G. Teaching on precise pulse diagnosis by Guangyu Wang. 2nd ed. Beijing: China Science and Technology Publishing House, 2016.
- [21] XU Y. Miraculous pulse diagnosis from the grand master. Taiyuan: Shanxi Science and Technology Publishing House, 2010.
- [22] QI X. Training course on systematic evidence-based pulse diagnosis. Beijing: People's Military Medical Press, 2013.
- [23] LIU J. Preliminary exploration on the relation between pulse diagnosis and body parts and its clinical usage. *Chinese Journal of Basic Medicine in Traditional Chinese Medicine*, 2003(12): 59–61.
- [24] XING Y, NIU X. Research on the procedure of deriving the mapping relation between the pulse manifestation at Cunkou and the Zangfu organs. *Journal of Traditional Chinese Medicine*, 2013, 54(12): 991–993.
- [25] FENG X, FENG J, ZHANG X. Confused TCM theory on pulse and viscera matching. *Guiding Journal of Traditional Chinese Medicine and Pharmacy*, 2002, 8(5): 222–226.
- [26] VELIK R. An objective review of the technological developments for radial pulse diagnosis in Traditional Chinese Medicine. *European Journal of Integrative Medicine*, 2015, 7(4): 321–331.
- [27] WANG YY, WANG SH, JAN MY, et al. Past, present, and future of the pulse examination (mài zhěn). *Journal of Traditional and Complementary Medicine*, 2012, 2(3): 164–185.
- [28] CHU YW, LUO CH, CHUNG YF, et al. Using an array sensor to determine differences in pulse diagnosis—three positions and nine indicators. *European Journal of Integrative Medicine*, 2014, 6(5): 516–523.
- [29] NICHOLLS J. From neuron to brain. 5th ed. Sunderland: Sinauer Associates, 2012.
- [30] SHI YB, YANG HY, YUAN RH. Discussion on characteristics of radial pulse manifestation from the perspective of tactile frequency and threshold. *Journal of Traditional Chinese Medicine*, 2021, 62(14): 1218–1223.
- [31] DAHIYA RS, METTA G, VALLE M, et al. Tactile sensing—from humans to humanoids. *IEEE Transactions on Robotics*, 2010, 26(1): 1–20.
- [32] TSAI YN, HUANG YC, LIN SJ, et al. Different harmonic characteristics were found at each location on TCM radial pulse diagnosis by spectrum analysis. *Evidence-Based Complementary and Alternative Medicine*, 2018, 2018: 9018271.
- [33] WEI CC, HUANG CM, LIAO YT. The exponential decay characteristic of the spectral distribution of blood pressure wave in radial artery. *Computers in Biology and Medicine*, 2009, 39(5): 453–459.
- [34] WIND GG, VALENTINE RJ. Anatomic exposures in vascular surgery. 3rd ed. London: Wolters Kluwer, 2013.
- [35] JIANG S. Human homolography. Beijing: People's Health Publishing House, 2000.
- [36] VLACHOPOULOS C, O'ROURKE M, NICHOLS WW. McDonald's blood flow in arteries: theoretical, experimental and clinical principles. 6th ed. London: CRC Press, 2011.
- [37] GUYTON AC, HALL JE. Textbook of medical physiology. 11th ed. Philadelphia: Saunders, 2005.
- [38] LEVICK R. An introduction to cardiovascular physiology. 5th ed. London: CRC Press, 2009.
- [39] SHI YB, VALVERDE I, LAWFORD PV, et al. Patient-specific non-invasive estimation of pressure gradient across aortic coarctation using magnetic resonance imaging. *Journal of Cardiology*, 2019, 73(6): 544–552.

- [40] SHI YB, VALVERDE I, LAWFORDE PV, et al. Comparison of stenosis models for usage in the estimation of pressure gradient across aortic coarctation. *Journal of Biological Physics*, 2021, 47(2): 171-190.
- [41] RHODE KS, HILL DLG, EDWARDS PJ, et al. Registration and

- tracking to integrate X-ray and MR images in an XMR facility. *IEEE Transactions on Medical Imaging*, 2003, 22(11): 1369-1378.
- [42] LI Z, ZHEN JIA ZHENG YAN. Beijing: China Medical Science Press, 2011.

基于触觉感知的简化模型研究寸口处脉象差异

史宇兵^{a, b*}, 杨洪义^a, YEO Joon Hock^c

a. 陕西中医药大学整合医学研究院, 陕西 咸阳 712046, 中国

b. Department of Mechanical, Materials & Manufacturing Engineering, University of Nottingham Malaysia Campus, 43500 Semenyih, Selangor Darul Ehsan, Malaysia

c. School of Mechanical and Aerospace Engineering, Nanyang Technological University, 639798, Singapore

【摘要】目的 中医脉诊理论认为腕部桡动脉处（称为寸口）的脉象表征着人体不同脏腑器官的生理病理状况。然而，研究人员对于脉诊技术的客观性存在不同看法，部分研究人员提到在不同的寸口部位未观察到显著的脉象差异，通过寸口脉象辨别不同器官的状态可能存在一定难度。本研究通过对触觉感知特性的简化数学建模来分析寸口处的脉象，从而对上述问题进行探讨。**方法** 基于 Weber-Fechner 定律，将诊脉过程中的触觉感知变化描述为带宽随不同取脉压力而变化的低通信号滤波器。应用该模型分析本研究组此前采集的临床数据，对 14 例介入测量得到的主动脉缩窄患者的动脉血压数据进行处理，以模拟不同取脉压力作用于寸关尺部所形成的脉象差异。**结果** 考虑触觉感知特性时，伴随取脉压力的变化诊脉中寸口处不同脉深的脉象存在显著差异；而采用传感器测量时由于不存在触觉感知特性的影响，所得到的脉象则没有这种随脉深的变化。这就解释了为什么中医直接诊脉与现代脉诊学使用传感器测量会对脉象形成不同的理解。此外，采用本研究中建立的触觉感知模型所计算出的寸口处浮中沉不同脉深的脉象特征，与中医脉搏理论中的相关描述一致。**结论** 本研究通过建立触觉感知模型，初步解释了中医脉诊理论中的脉象随取脉压力变化现象。将触觉感知建模引入中医脉诊研究，开启了图象化表达脉象以对其进行定量分析的新的探索窗口，这不仅有效扩展了脉诊研究的范畴，也为现有脉诊仪的技术升级和功能优化提供了科学依据。

【关键词】 脉象；中医；寸口；触觉感知；数学模型