

Design Evolution: From Rolling Piston to Revolving Vane to Cross-Vane Expander-compressor unit

This content has been downloaded from IOPscience. Please scroll down to see the full text.

2015 IOP Conf. Ser.: Mater. Sci. Eng. 90 012036

(<http://iopscience.iop.org/1757-899X/90/1/012036>)

View [the table of contents for this issue](#), or go to the [journal homepage](#) for more

Download details:

IP Address: 155.69.250.114

This content was downloaded on 21/10/2016 at 08:44

Please note that [terms and conditions apply](#).

You may also be interested in:

[Observation of Oil Flow Characteristics in Rolling Piston Rotary Compressor for Reducing Oil Circulation Rate](#)

S j Song, K Y Noh, B C Min et al.

Design Evolution: From Rolling Piston to Revolving Vane to Cross-Vane Expander-compressor unit.

Ooi K T¹ and Yap K S²

^{1,2}Nanyang Technological University, 50, Nanyang Avenue, Singapore 639798

² TUM CREATE (Technische Universität München - Campus for Research Excellence And Technological Enterprise), 1 CREATE Way, #10-02, CREATE Tower, Singapore 138602

Abstract

In this paper the design evolution from rolling piston compressor (RP) to revolving vane compressor (RV) and finally to cross-vane expander-compressor unit (CVEC) is presented and discussed. The details in the design philosophy which initiated this evolution will be presented and discussed.

It is estimated that more than 90% of the room air-conditioners uses RP in its compressor. This is because of its advantages: it has the few parts, it is simple geometrically and it is reliable. However, it is with no weaknesses. RP's weaknesses lie in three parts:

- too many rubbing surfaces with high relative rubbing velocity with each other which give rise to high frictional losses;
- components (eccentric and roller) are not rotating at their centres and resulted in unnecessary inherent vibration;
- vane tip is constantly rubbing against the roller making it a weakest part in design.

To overcome RP's weaknesses, RV is introduced. As compared to RP, RV has fewer rubbing surfaces, and the relative velocities among these surfaces are reduced. Components in RV rotate at their own centres and there is no inherent vibration; the rubbing at the vane tip has been eliminated completely.

However, like RP, RV also has a large rotor which occupied "useful" space and making the working chamber relatively small. To overcome this latter problem, CVEC is introduced. In this newly invented CVEC, not only parts are all concentric and rotate at their own centres, the unit also recovers expansion energy and hence significantly reduces energy required by the refrigeration systems. And, more importantly, all these are carried out not at the expense of the additional cost.

In this paper, details on these three compressors are explained, compared and their respective uniqueness are shown and discussed.

1. Introduction

Literature shows that significant research has been carried out to arrive at what we have today for a relatively energy efficient running refrigeration compressors. Among the most popular compressors in use today, there are rolling piston, reciprocating, scroll and screw. Rolling piston compressor (RP) is generally used for cooling capacity below 15 kW, though recently more and more RPs are used for cooling capacity of 15kW and above. In room air-conditioners applications, more than 90% of the



compressor used RP. This is because of its simple geometry, few parts and relatively reliable. However, RP has some design weaknesses such as significant frictional losses due to a number of rubbing surfaces which have high relative rubbing velocity to each other; components (eccentric and roller) are not rotating at their centres and resulted in unnecessary inherent vibration; vane tip is constantly rubbing against the roller making it a weakest part in design.

To overcome RP's weaknesses, revolving vane compressor (RV) is introduced. RV has fewer rubbing surfaces, and the relative velocities among these surfaces are reduced. Components in RV rotate at their own centres and hence no inherent vibration, and there is no vane tip contact.

However, RP and RV have large rotors which occupied "useful" space. To overcome this, CVEC was introduced. In CVCE, not only parts are all concentric and rotate at their own centres, the unit also recovers expansion energy and hence significantly reduces energy required by the refrigeration systems. In this paper, details on these three compressors are explained, compared and their respective uniqueness are shown and discussed.

2. Rolling piston compressor

Rolling piston compressor is one of the most widely used compressors in room air-conditioners. It is mostly used in the applications where the cooling capacity is lower than 15 kW. Figure 1 shows a schematic diagram of a rolling piston compressor. In its basic form, it consists of five components: A cylinder (call stator), a roller, an eccentric, a vane and a discharge valve.

During operation, the roller rolls in the cylinder but maintaining contact with the cylinder and the vane tip at all time, creating two working chambers. These working chambers are bounded by inner surface of the cylinder, outer surface of the roller and the vane. While one chamber is expanding, hence suction process, the other is compressing hence compression process. Once the gas pressure reaches that of the discharge pressure, the gas is discharged out of the working chamber through the discharge port.

There are six areas of frictional losses [2]:

1. Eccentric and the inner surface of the roller,
2. Roller face and the cylinder head face,
3. Eccentric face and the cylinder head face,
4. Vane tip and roller,
5. Vane sides and vane slot,
6. Outer roller surface and the inner cylinder surface.

For item (1) above, the rubbing between the inner surface of the roller and the eccentric is dependent on the forces acting on the roller and the viscous forces at the rubbing surfaces. For the items (2) to (6) the rubbing is between moving surfaces against stationary surfaces, hence the relative velocity responsible for the friction is relatively large. Attention must also be paid to the rubbing at the vane tip and the roller. This latter rubbing region is a critical rubbing part, this is because a small region of the vane tip rubs against a relatively large outer surface of the roller, causing vane tip to wear easily, and in practice, the vane and the roller are hardened to reduce wear.

It is noted that also, the main driving component for the RP is the eccentric. The motion of eccentric drives the roller and hence forming the compression and the suction chambers mentioned earlier. This eccentric inherently introduce "wobbling" motion which induces vibration.

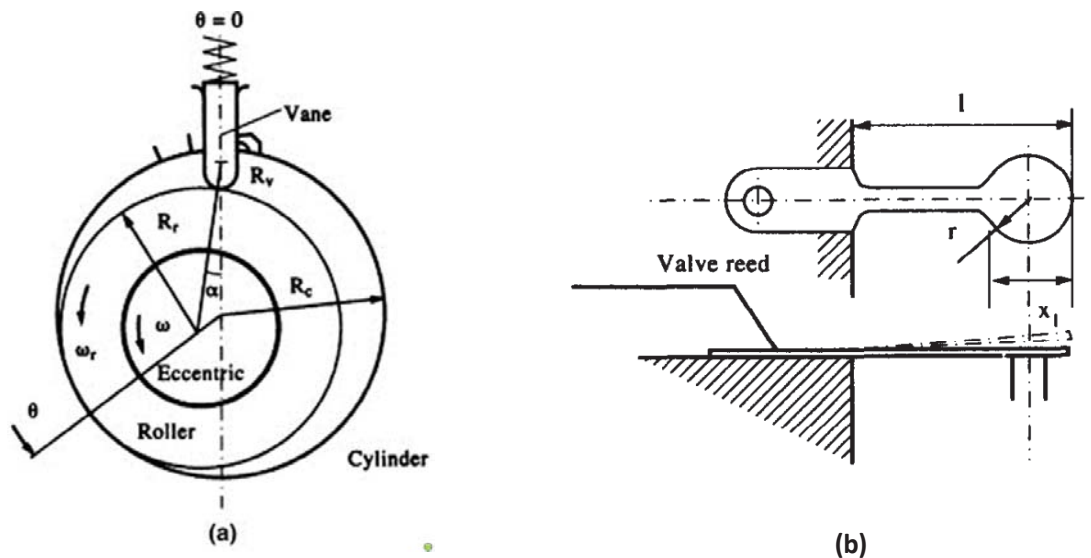

R_c	cylinder radius (m)
R_r	roller outer radius (m)
R_v	radius of vane tip (m)
R_s	shaft radius (m)
ω	angular velocity of crankshaft (rad/s)
ω_r	angular velocity of roller (rad/s)

Figure 1 (a) Schematic of a rolling piston compressor [1], (b) Discharge valve [2]

3 Revolving vane compressor

RV compressor [3,4] is introduced to mitigate the disadvantages inherently in the RP. Figure 2 shows the schematics of the RV. In its basic form, RV compressor has 4 parts: a cylinder, a rotor, a vane and a discharge valve (no shown). Figure 3 shows the snapshots of the operation of the RV.

One of the distinguishing feature of the RV is that during the operation, the cylinder rotates together with the rotor. The rotating cylinder rotates the two end faces of the cylinder as well, hence making all the rubbing surfaces have lower relative velocity and hence reduces the frictional loss significantly. Refer to the six items of frictional areas mentioned in section 2 for RP, in the design for RV, there is no eccentric, the frictional losses caused by items (1) and (3) are no longer present. Since the cylinder is also rotating, items (2) and (6) in section 2, have significantly lower friction. Vane tip in RV design is longer rubbing against any surface and hence item (4) is totally eliminated. Item (5) in section 2, has a

very significant improvement. Since the vane is now rigid secured on to the cylinder, the vane slot which rubs against the vane surfaces is now located at the rotor. It is this arrangement that predominantly caused the vane side friction to be completely independent from the pressure differential across the vane! This has a huge significance especially when the compressor is operating under a high pressure difference condition between the suction and the discharge, such as those when using CO₂ as the refrigerant. Thus, frictional loss caused by item (5) has high implication in performance improvement in the case for RV when compared to RP. The frictional loss caused by item (5) for RV is only dependent on the rotating inertia of the rotor.

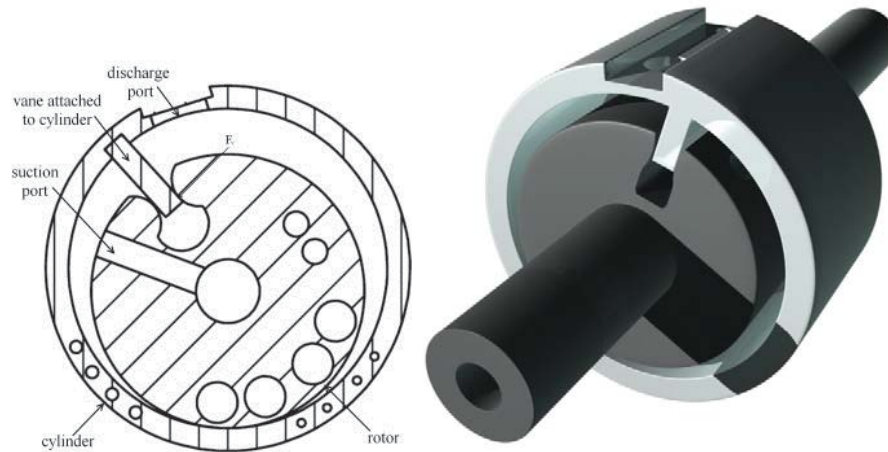

Figure 2 Schematics [3] and 3-D mark-up of the fixed-vane revolving vane compressor.

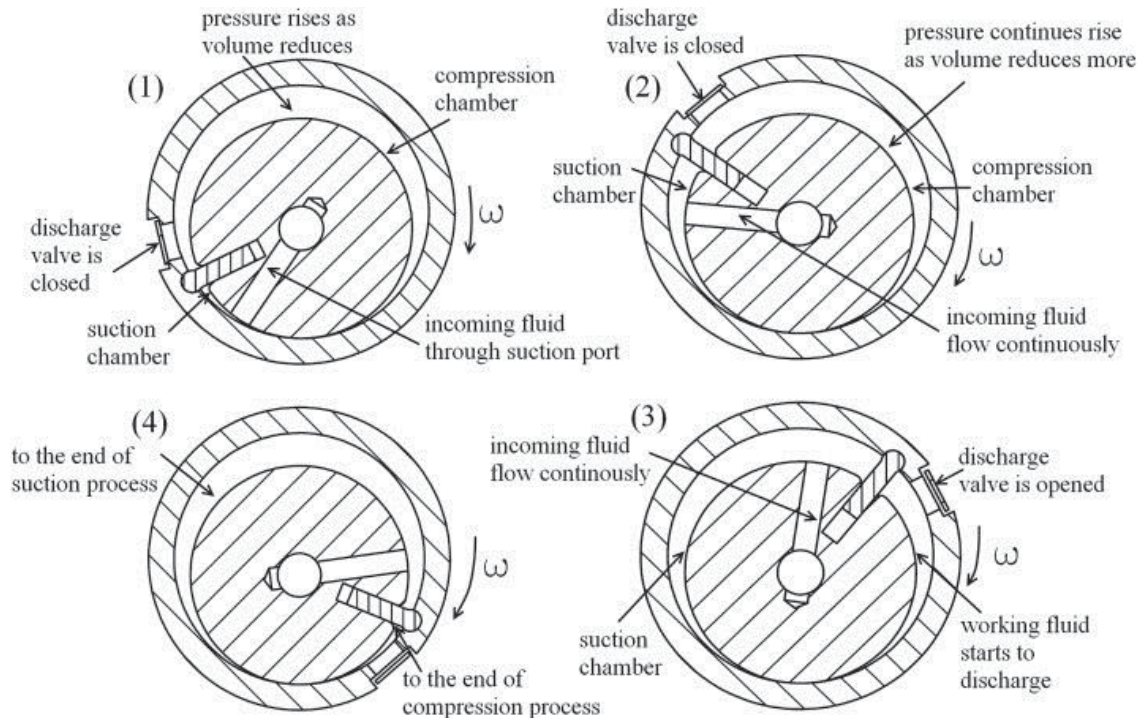

Figure 3 Snapshots of revolving vane compressor operation [4]

The revolving vane compressor can be designed with swiveling vane or fixed vane and the vane can be fixed either on the cylinder or on the rotor. Figure 5 shows the inertia torque variations for these different designs. It is advisable to fix the vane on the driving component, i.e. if the vane is fixed on the cylinder, the cylinder should be the driving component and vice-versa.

The revolving vane compressor can be designed with swiveling vane or fixed vane and the vane can be fixed either on the cylinder or on the rotor. Figure 5 shows the inertia torque variations for these different designs. It is advisable to fix the vane on the driving component, i.e. if the vane is fixed on the cylinder, the cylinder should be the driving component and vice-versa.

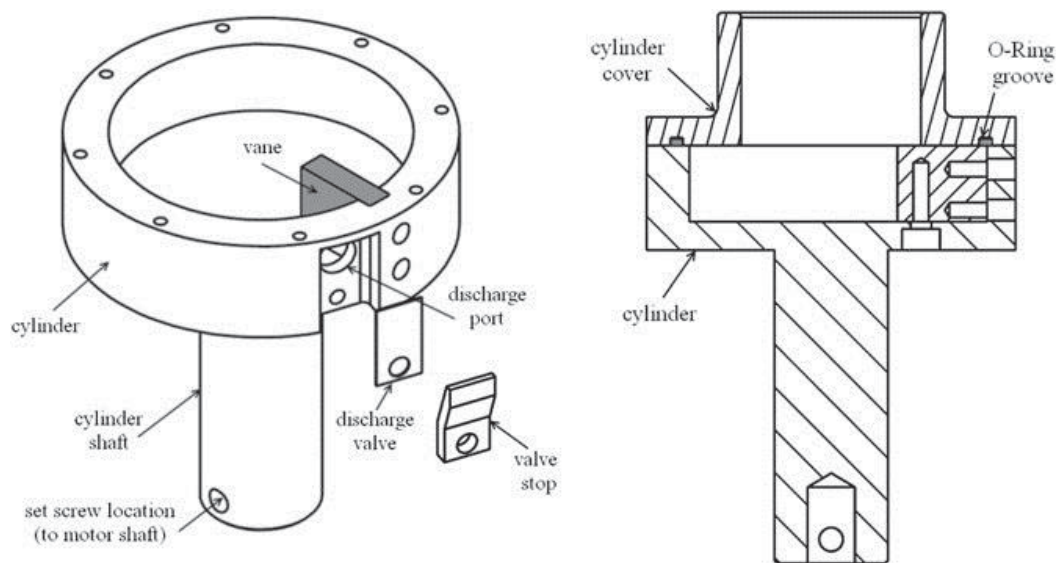

Figure 4 the cylinder assembly components of revolving vane compressor [5].

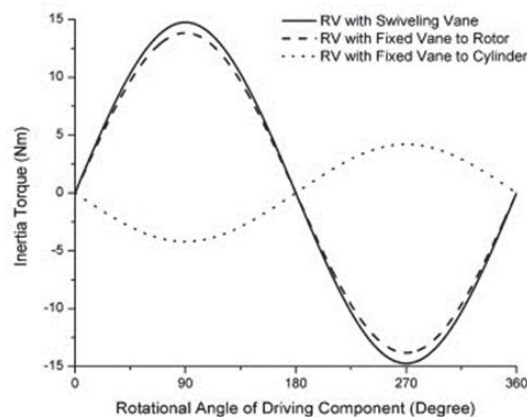

Figure 5 Variations of the inertia torque over three different revolving vane compressor designs [3]

4 Cross vane compressor-expander unit

Referring to RP and RV in figures 1(a) and 2 respectively, it can be seen that the available working spaces (working chamber) of the two compressors are relatively small as compared to the overall size of the compressor. This is because the useful space has been “occupied” by a relatively large rotor. It can be seen from the two figures that the rotors for both design are relatively large as compared to the cylinder, and the working chamber is comparatively small. The next question is that will we be able to make use of the “space” occupied by the rotor and makes the compressor or the refrigeration cycle works better. This thought has lead to the born of the cross-vane compressor expander unit (CVEC) [6,7]. Figure 6 shows the sschematics of the CVEC. It can be seen immediatly that the “rotor” is no longer a “solid” cylinder but a “hollow” cylinder. In fact the space created by this “hollow” rotor is actual an expander!

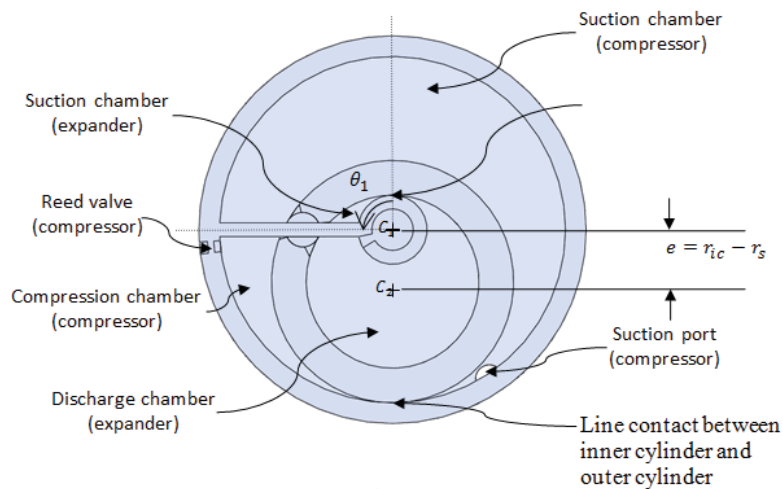

Figure 6 schematics of the cross-vane expander compressor unit.

During operation, the rotation of the shaft causes the vane to rotate which in turn rotates the cylinder for compressor and the expander. Figure 7 illustrates the snapshots of the operation of CVEC. The motion causes the volumes trapped within the suction and compression chamber of the compressor to vary, resulting in suction, compression and discharge of the working fluid. Similarly, the volumes trapped within the suction and discharge chamber of the expander varies too, resulting in suction, expansion, and discharge of the working fluid. Both the compressor and expander operate concurrently.

Such a machine is best to work with working fluids which operates on large pressures between suction and discharge of the compressor, such as CO₂. This large pressure difference will result in a significant power being recovered, which, otherwise wasted at the expansion valve, and hence increases significantly the overall COP of the CO₂ cycle. Theoretical analysis (not shown) shows that 14-40% COP increase is possible.

Figure 8 shows schematics of a refrigeration cycle fitted with CVEC. It is noted that the expansion valve and the compressor is now replaced by CVEC.

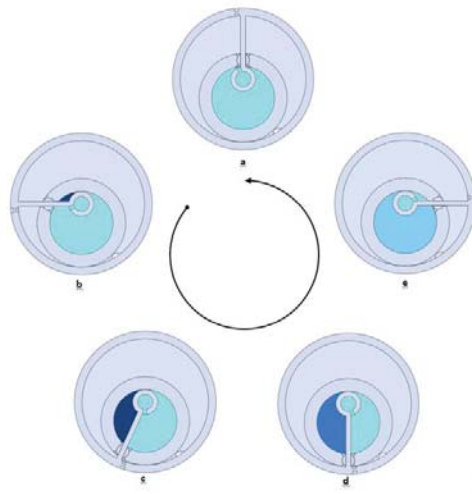

Figure 7 Operation snapshots of cross-vane expander compressor

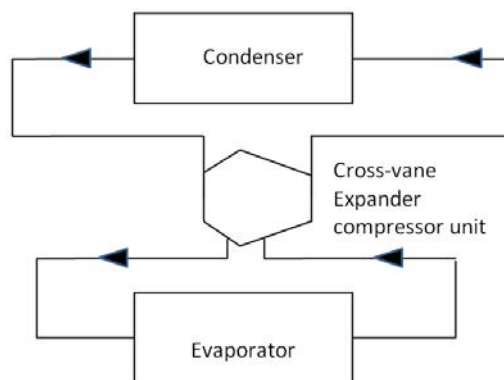

Figure 8 Schematics of a refrigeration cycle fitted with CVEC

To understand the behaviour of the CVEC in a greater detail, the components of the instantaneous power of the machine is shown in Figure 9 and these are: compression power, expansion power, inertial power, and total frictional power loss. The phase difference has resulted in the decrease of CVEC peak power of about 4.3%. This improvement is still relatively small, and ideally, the peak power of the compressor and expander should be matched at the same instance. This not only reduces the peak power of the CVEC further, but also ensures that all the recovered power from the expansion process is fully utilized throughout the cycle.

All in all, the average power of the compressor, expander, inertial effect, and total frictional loss are calculated to be 1181.6W, 213.2W, 0W, and 31.3W respectively. The average expansion power is 18.0% of the compression power, and when it is utilized to partially drive the compressor, an improvement of 21.3% in the COP of the refrigeration cycle could be achieved. In addition, the average total frictional loss is comparatively small too, and as a result, a mechanical efficiency of the CVEC of 96.9% could be obtained.

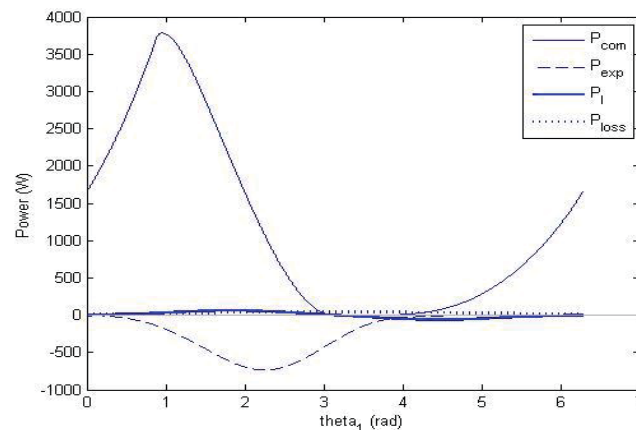

Figure 9 Instantaneous power constituents of cross-vane expander compressor

5. Conclusion

Rotary compressor has recorded an annual sale of more than 150 million units in 2013 [8]. With constant design improvement of the compressor, the energy efficiency of the refrigeration cycles can be improved. This improvement will bring about significant energy and materials saving. In this paper, CVEC is useful not only it reduces the mechanical power loss but it also recovers expansion energy in the vapour compression refrigeration cycle, which is otherwise lost, into useful energy to supplement the power needed by the compressor. With its simple geometry and fewer parts, it is expected that there will not be any manufacturing cost increase when using this CVEC with the existing refrigeration cycle, but significant operational cost saving is expected. It is particularly true when it is employed in the CO₂ refrigeration cycle.

References

- [1] Ooi K T 2005 Design optimization of a rolling piston compressor for refrigerators *Applied Thermal Engineering*, Vol 25 Issues 5–6 pp 813 – 829
- [2] Ooi K T and Wong TN, (1997), A computer simulation of a rotary compressor for house-hold refrigerators. *Applied Thermal Engineering*, 17(1) pp 65-78.
- [3] Tan K M and Ooi K T 2011 A novel revolving vane compressor with a fixed-vane. *Int. J. Refrigeration* 34(8) pp 1980-1988.
- [4] Tan K M and Ooi KT 2010 Journal bearings design for a novel revolving vane compressor, *Int. J. Refrigeration*, 34 (1), pp. 94–104
- [5] Tan K M and Ooi K T 2014 Experimental study of fixed-vane revolving vane compressor. *Applied Thermal Engineering* 62(1) pp 207-214.
- [6] Yap K S and Ooi K T and Chakraborty A 2014 Introduction of the Novel Cross Vane Expander-Compressor Unit for Vapour Compression Cycle *International Compressor Engineering Conference at Purdue* p 1129
- [7] Yap K S, Ooi K T and Chakraborty A 2014 Modelling and Simulation of the Dynamics of Cross Vane Expander-Compressor Unit for Vapour Compression Cycle, *International Compressor Engineering Conference at Purdue*, p 1134
- [8] Cover story, JARN, September 2013, Serial no 536, 45(9).